

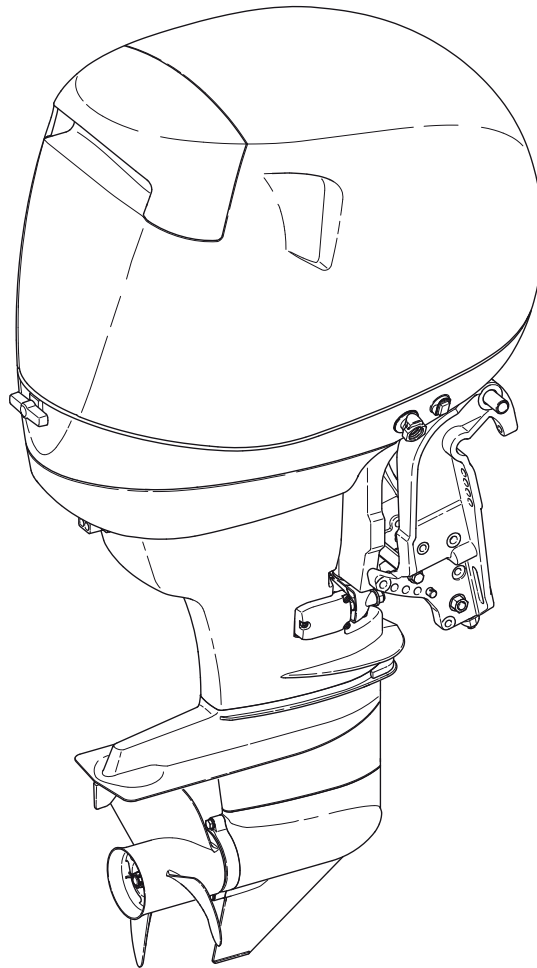

Owner's manual

Dtorque 111



Always read this owner's manual **before** handling the outboard engine as it contains important information on installing, starting up, operating and maintaining the engine.

Keep this owner's manual within easy reach of the outboard engine.



This owner's manual has been translated into several different languages. The German owner's manual is the original version. All other languages are translations of the German original owner's manual.

© 2017 Neander Shark GmbH

This owner's manual contains information which is covered by copyright regulations. This owner's manual may not be copied, printed, filmed or reproduced in any other way, edited, duplicated or distributed – neither in full nor in part – without prior written consent. Neander, Neander Shark and Dtorque are registered trademarks of Neander Motors AG. Any companies, brands or registered trademarks are property of the respective copyright holder and are only used in this owner's manual for the purpose of identifying or describing functions or products.

This edition (01, 10.2017) applies to the 2017 **Dtorque 111** turbo diesel model.

Neander Shark GmbH

Werftbahnstraße 8
24143 Kiel
Germany

Telephone +49 431 7028 230

Fax +49 431 7028 235

info@neander-shark.com

■ **About this owner's manual**

Purpose 11

Storage location 11

Copyright protection 11

Additional documents 12

Feedback on the owner's manual 12

■ **Safety**

Organizational measures 13

Safety of people 13

Preventing material damage 13

Environmental protection 13

General safety precautions 14

Operating conditions 14

Before start-up 14

Faults 14

Maintenance, overhaul, repair 14

Modifications, accessories 14

Electric system 14

Handling fuels/lubricants 14

Cleaning, lubrication 14

Safety features 15

Cowling and flywheel fan guard 15

Starter interlock 15

Stop button 15

Kill switch lanyard 15

Transport lock 15

Danger points 16

Propeller 17

Transom 17

Flywheel fan and flywheels 17



Indications used in this owner's manual18

■ **Description of the outboard engine**

Declaration of Conformity19

Intended use19

Scope of delivery.....20

The Dtorque 11121

Area of application.....21

Main features and advantages21

Patented dual crankshaft design.....22

Patented lateral guidance of the piston thanks to the spaceball.....23

Robust and easy-to-maintain cylinder block.....24

Durability and efficiency24

Components25

Overview of assemblies25

Propeller26

Anti-cavitation plate.....26

Transom26

Trab trim26

Power trim.....26

Overview of the engine block27

Fuel system.....29

Controls, connectors and indicators.....31

Right-hand side of the engine.....31

Left-hand side of the engine.....32

Tiller handle (optional).....33

Control box (optional).....37

■ **Installation**

Unpacking41

Transporting the packaging.....42

Removing the packaging.....42

Lifting from the transport pallet.....43



Fixing to the boat	45
Preparations	45
Attaching to the boat	47
Removing the transport lock	51
Installing the control box and steering linkage	52
Installing the tiller handle	58
Installing the mechanism for the steering resistance	59
Battery	60
Fuel tank	61
Connections to the engine	62
Settings	69
Adjusting the control cables	69
Adjusting the control resistance	72
Adjusting the steering resistance	72
Adjusting the trab trim	73
■ Operation	
Safe operation	75
Start-up	75
Travel	76
Stopping	76
Environmental protection	76
Breaking-in instructions	77
Cold start	78
Special operating conditions	79
Operating at low temperatures	79
Operation in salt water	80
Handling the cowling	81
Removing the cowling	81
Installing the cowling	81
Preparing for operation	82
Before each operation	82
Refueling	82

Connecting the kill switch lanyard	84
Start-up	85
Normal start	85
Special preparations for the first start	87
Travel	88
Controlling the engine speed	88
Changing gears with the tiller handle	90
Changing gears with the control box	92
Steering	94
Holding the steering resistance	95
Trimming using the power trim	96
Economical operation	97
Shallow water operation	97
Traveling slowly	98
Checking operational safety during travel	99
Heed warning signals	99
Stopping	100
Ending operation	101
Tilting	101
Switching off	102
After every operation	102

■ **Faults**

Troubleshooting table	103
Fault codes	109
Example: only 1 fault code stored	109
Example: 2 fault codes stored	109
Displaying fault codes	110
Engine protection functions	111
Oil temperature	111
Cooling water temperature	111
Oil pressure	112
Cooling water pressure	112



Boost pressure 112

■ **Maintenance**

Maintenance tasks 113

Cleaning 114

After every operation 114

Regularly 114

Inspection 115

Inspection intervals 115

Visual inspections and checks 116

Inspecting the safety features 116

Checking the oil fill level. 118

Checking the propeller 119

Checking the sacrificial anodes 120

Checking the warning signs and information stickers 121

Service 122

Safety when performing maintenance tasks 122

Maintenance intervals 122

Flushing the cooling circuit. 124

Checking the tightening torques on the exhaust elbow 125

Emptying the water separator 126

Replacing the fuel filter element. 128

Emptying the water separator in the fuel feed line. 130

Replacing the fuel filter element in the fuel feed line 130

Cleaning the fuel tank 130

Replacing the oil filter. 131

Replacing the idle relief cover 133

Lubrication 135

Changing the engine oil 137

Changing the transmission oil 140

Refilling hydraulic oil 142

Repairs 144

Safety when carrying out repairs 144



Repairing the propeller 144

Replacing the propeller 145

Replacing the sacrificial anodes 149

Replacing a fuse 152

Replacing a relay 153

Replacing a power trim relay 154

Checking and adjusting the cowl lock 155

Engine under water 156

■ **Transport, packaging, storage**

Removal from the boat 157

Preparations for lifting 157

Twin propulsion 158

Disconnecting the steering linkage and control box 159

Disconnecting the battery leads and the fuel lines 159

Disconnecting the battery 159

Preparing the duct 160

Disconnecting electrical leads 160

Disconnecting the battery leads from the engine 161

Disconnecting the fuel lines from the engine 162

Locking the steering 163

Installing the transport lock 164

Transport 165

Shipping conditions 165

Trailer transport 165

Checking the transport lock 166

Transport pallet 166

Fastening to the transport pallet 167

Additional packaging 169

Transport pallet transportation 169

Storage 170

■ **Appendix**



Technical data	171
Mechanical systems	171
Common rail system	172
Electric system	172
Ambient conditions	172
Permitted fuels/lubricants	173
Emissions	173
Vibration	173
Dimensions of outboard engine	174
Dimensions of transom	175
Dimensions of shipping crate	176
Dimensions of transport lock	176
Fuses and relays	177
Accessories	178
Approved propellers	178
Approved fuel filter inserts	179
Approved fuel filter in the fuel feed line	179
Approved fuel lines	179
Spare parts	180

■ **Index**



– Blank page –



About this owner's manual

Purpose

The purpose of this owner's manual is to introduce the Dtorque 111 outboard engine and to provide information on how to operate and service it safely and correctly.

This owner's manual does not contain information on extensive repair tasks or replacing parts. Such tasks are described in the workshop handbook.

Neander Shark considers it important to operate the outboard engine in a safe, appropriate, economical and environmentally friendly way. To that effect, it is essential you read through this owner's manual thoroughly before starting any work on the outboard engine. The owner's manual contains important information which will help you prevent any hazards, maintain the engine's reliability and increase its service life.

Please pay particular attention to the chapter on *Safety* from page 13 onwards. Follow the instructions carefully to ensure that both you and others remain safe and to prevent damage.

Storage location

The owner's manual must always be kept close to the outboard engine. It must be read and followed by anyone working on or with the outboard engine.

Be sure to select a storage location where the owner's manual will not be damaged and will remain legible and in good condition throughout the entire service life of the engine.

Scope

This owner's manual must be read, understood and followed in full by anyone who works on or with the outboard engine.

The tasks include the following:

- Transport
- Installation and preparations for use
- Operation
- Troubleshooting
- Cleaning
- Maintenance (service, inspection)
- Storage

This also applies to users who have previously worked on an identical or similar outboard engine.

Copyright protection

This owner's manual should be treated as confidential. It is only intended for people working on or with the outboard engine.

The content of this owner's manual (text, images, illustrations, drawings, schematic diagrams or any other representation) is protected by copyright.

Transfer

The owner's manual should be kept with the outboard engine at all times. If the outboard engine is moved to a different location or sold to another operator, the owner's manual must also be handed over to the new user.

Additional documents

In addition to this owner's manual, we provide further documents containing technical information:

- Workshop handbook
- Service book

These documents contain specific, detailed information which goes above and beyond the descriptions in this owner's manual.

Be sure also to take into account any separate documentation of individual component manufacturers.

Further information

If you have any other questions regarding the handling of the outboard engine to which you cannot find the answers in this owner's manual, please contact us at:

Yanmar Europe B.V.

Brugplein 11,
1332 BS Almere, The Netherlands

Telephone +31 36 5493200

Fax +31 36 5493209

marine.service@yanmar.nl

Feedback on the owner's manual

This owner's manual was compiled taking into account all of the relevant laws, guidelines, provisions and findings to the best of our knowledge. An owner's manual is, however, not a static document and so must be constantly monitored and regularly checked for possible improvements.

Please get in touch with us if you have any suggestions for improvement or comments on this owner's manual. We welcome and examine all contributions.

Safety

Organizational measures

The Dtorque 111 outboard engine has been constructed in accordance with the latest advances in technology and all widely recognized safety requirements, however there is still the chance of hazards when handling the outboard engine.

This owner's manual must be read, understood and followed in full by anyone who works on or with the outboard engine. This applies particularly to people who only work sporadically on or with the outboard engine.

As the operator of an outboard engine, it is your duty to ensure it is used safely and with as little risk as possible. Carrying out the following actions will achieve that:

- always keep the owner's manual within easy reach of the outboard engine;
- carry out training sessions for users;
- carry out continuous evaluation of the safety and risk awareness of everyone working regularly on or with the outboard engine.

Any warning signs and notices on the outboard engine must remain legible and undamaged, and must not be removed under any circumstances.

Safety of people

Anyone working on or with the outboard engine must be competent to do so or at least have received some instructions beforehand from someone who is. A competent person is someone who has sufficient knowledge about the handling of outboard engines and who is familiar with the relevant local occupational safety and accident prevention regulations thanks to their technical training and experience and is therefore able to evaluate the condition and safety of the outboard engine.

People working on or with the outboard engine must not do so under the influence of drugs, medicine or alcohol.

Personal protective equipment

Personal protective equipment must be available and used if necessary when operating or maintaining the outboard engine. Personal protective equipment includes protective gloves, ear protection, protective footwear, safety glasses, close-fitting work clothes and a hairnet for long hair.

Preventing material damage

As the operator of the outboard engine, you are responsible for the following:

- Ensure the outboard engine is used exclusively for its intended purpose (see *Intended use* on page 19).
- Ensure the outboard engine is used according to the operating conditions described in this owner's manual (see *Technical data* from page 171 onwards).
- Comply with the specified maintenance intervals.
- Ensure that only original parts and fuels/lubricants recommended by Neander Shark are used.

Environmental protection

Comply with all international, national, local and internal requirements regarding the environment.

Fuels and lubricants such as diesel and engine oil contain poisonous substances. These must not be released into the environment.

Fuels and lubricants must be disposed of by specialized companies.

General safety precautions

Operating conditions

The outboard engine must only be operated within the permitted limits (see *Intended use* on page 19 and *Technical data* from page 171 onwards). The engine must not be used in explosive atmospheres or in conjunction with explosive materials.

Before start-up

Before using the outboard engine, ensure that it has been inspected by a trained person who can verify it is operating safely and correctly, especially after any maintenance tasks or technical modifications.

Ensure that there is no risk to people when starting up the outboard engine. During operation, ensure that there is no risk to people from the propeller in the water. Shut down the outboard engine immediately if people should be near the propeller in the water.

Faults

Any faults which can affect the safety must be corrected immediately. The outboard engine must only be restarted once all faults have been corrected.

Maintenance, overhaul, repair

As operator of the outboard engine, ensure that only qualified professionals carry out any maintenance or repair tasks.

Any work on the outboard engine which is not described in this owner's manual or in the workshop handbook must only be carried out by the Neander Shark customer service team.

Modifications, accessories

Any modifications to the outboard engine should only be made in consultation with Neander Shark. Any modifications carried out without the manufacturer's approval can result in serious malfunctions which can lead to personal injury and irreparable material damage. The same is true for any additions or the use of accessories which have not been supplied by Neander Shark.

Neander Shark cannot accept any responsibility for damages or consequential damages caused by the use of components or spare parts which are not Neander Shark originals or approved by Neander Shark.

Electric system

Work on the electrical components of the outboard engine must be carried out in accordance with electrotechnical regulations by a qualified electrician or individuals that have received appropriate training.

Ensure that electrical components are protected against humidity and water penetration at all times.

Handling fuels/lubricants

Familiarize yourself with all fuels/lubricants used in and in conjunction with the engine, especially with regard to any risk they might pose via the skin or respiratory tract. When necessary, wear suitable personal protective equipment such as protective gloves, goggles or a breathing mask.

Cleaning, lubrication

Ensure that the working environment and floor remain free of cleaning fluids and waste lubricant, especially after undertaking any cleaning or lubrication tasks. If any liquid is spilled on the floor, there is a danger that people can slip, fall over and suffer from serious injuries.

Safety features

The outboard engine must only be operated in accordance with correctly functioning protection and safety features. Immediately stop using the outboard engine if any of the safety features malfunctions or becomes ineffectual.

All safety features should be checked regularly (see page 116).

Bypassing, deactivating or removing protective and safety features is strictly prohibited as it can lead to very severe injuries and material damage.

Correctly install or activate all protective and safety features after carrying out any maintenance or repair work on the engine.

Cowling and flywheel fan guard

When closed, the cowling (consisting of an upper and lower section) prevents direct access to the engine block.

Access to the rotating parts under the cowling (the flywheel fan and flywheels) is prevented with an additional flywheel fan guard. This flywheel fan guard must always remain installed during operation.

The cowling must remain closed and locked during operation.

Starter interlock

The outboard engine can only be started up with the tiller handle shift lever or the control box shift and throttle lever in the neutral position. This prevents the boat from moving as soon as the outboard engine is started.

Stop button

The stop button on the tiller handle or control box opens the contact to prevent the engine from being started. To close the contact, the stop button must be pulled out against the resistance from a spring. This can be done by inserting the clip on the kill switch lanyard. Pulling out the clip automatically opens the electrical contact, which cuts the engine out and prevents it from being restarted.

Kill switch lanyard

The kill switch lanyard can be attached to the skipper's body. If the skipper goes overboard, the clip attached to the kill switch lanyard is pulled out of the stop button, which immediately cuts off power to the outboard engine. This can prevent or minimize the possibility of injuries caused by the propeller.

The second engine kill switch lanyard with a clip (provided) must be kept within easy reach. It will make it possible for the engine to be restarted even if the skipper goes overboard with the first kill switch lanyard.

Transport lock

The transport lock prevents the outboard engine from swiveling in the transom. The transport lock must be installed at all times when the outboard engine is being transported, even when it is fixed to the boat if there is no steering linkage.

Danger points

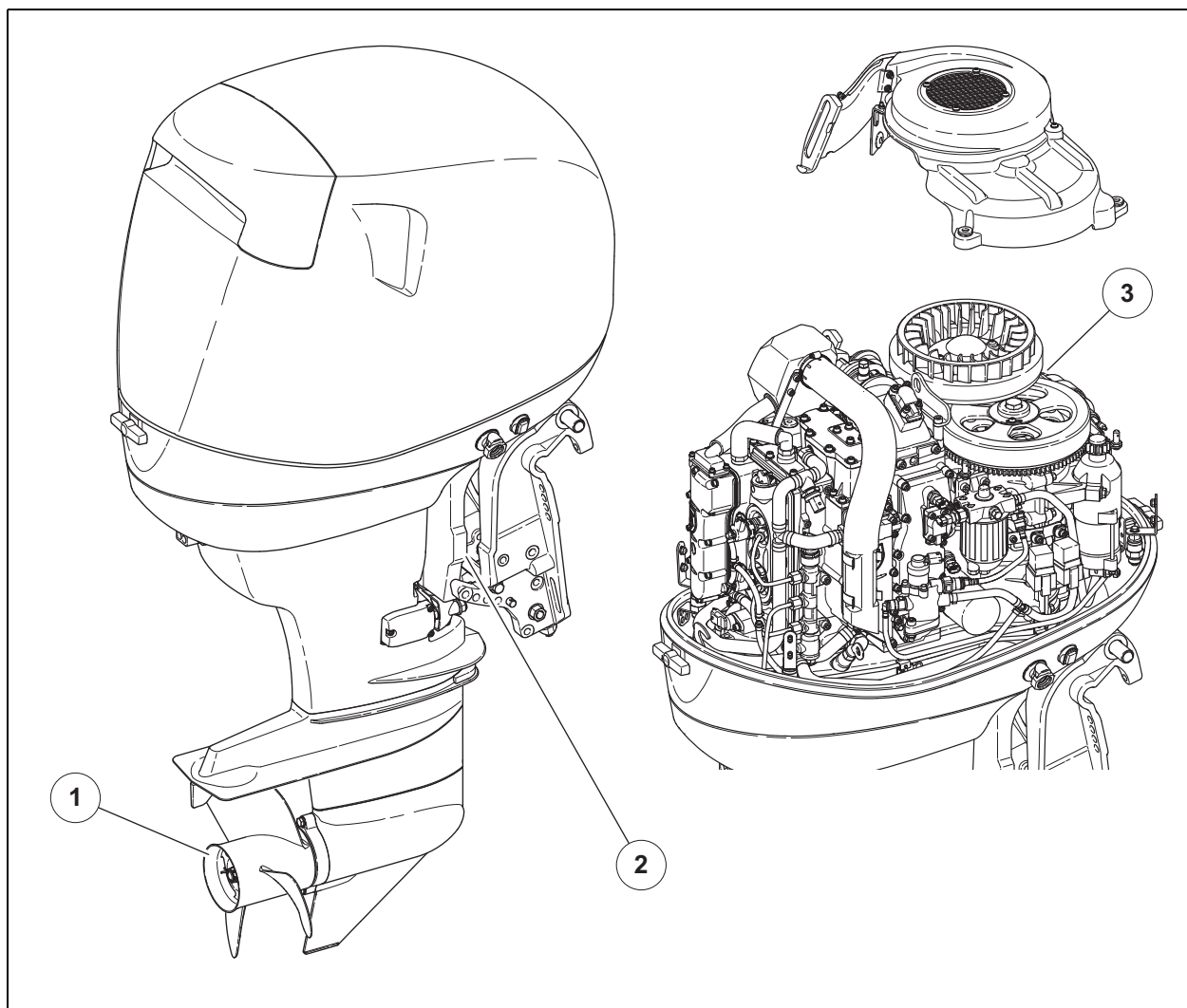

The main danger points on the outboard engine are:

- 1 Propeller
- 2 Transom
- 3 under the flywheel fan guard:
Flywheel fan and flywheels

Propeller

With rotating propellers, there is a

- risk of extremely severe cuts from the sharp blade edges, which can even result in death
- risk of injury due to catching loose clothing or long hair

There is still a risk of injury from the sharp edges even when the propeller is not rotating.

Transom

In the area around the transom, there is a

- risk of crushing between the transom and the casing if the engine moves (tilting and swiveling)
- risk of crushing between the engine casing and side of the boat if the engine moves (tilting and swiveling)

Flywheel fan and flywheels

With the flywheel fan guard removed, the rotating flywheel fan presents a

- hazard for cuts due to its sharp blade edges
- risk of injury due to catching loose clothing or long hair

With the flywheel fan guard removed, the flywheels can present a

- risk of crushing between the rotating and fixed components
- risk of injury due to catching loose clothing or long hair

Indications used in this owner's manual

The following symbols and indications are used in this owner's manual for safety-related information:



DANGER

[Source of danger, type of danger]

Indicates an immediately imminent danger to the life and limb of persons. Ignoring this type of warning will result in severe risks to health, including life-threatening injuries and even death.



WARNING

[Source of danger, type of danger]

Indicates a potentially imminent danger to the life and limb of persons. Ignoring this type of warning could result in severe risks to health, including life-threatening injuries and even death.



CAUTION

[Source of danger, type of danger]

Indicates a potentially dangerous situation. Ignoring this type of warning could result in minor injuries.

NOTICE

[Source of danger, type of danger]

Indicates a situation which could result in material damage.

Description of the outboard engine

Declaration of Conformity

The Dtorque 111 outboard engine is in conformity with the following directives of the European Parliament and European Council:

- 2013/53/EU
(recreational craft and personal watercraft),
- 2006/42/EC
(machinery),
- 2014/30/EU
(electromagnetic compatibility).

The outboard engine carries the CE marking on the rating plate.

Intended use

The Dtorque 111 outboard engine is used to drive and steer permitted watercraft in seawater, brackish water and fresh water. The watercraft must be appropriate for the weight and power of the outboard engine.

The propulsion of inland waterway vessels according to Directive (EU) 2016/1629 of the European Parliament and of the Council is prohibited.

The use of the outboard engine in conjunction with explosive materials is not permitted.

The propulsion and steering of other floating devices, platforms or islands is not permitted.

Proper use of the outboard engine includes observing the instructions given in the owner's manual and complying with the inspection/maintenance intervals as well as the limits of use (see *Technical data* from page 171 onwards) for the engine.

Any other use or application of the outboard engine beyond those specified is classed as non-intended use and is strictly prohibited.

Misuse

Misuse and abuse can endanger operational safety and result in serious injuries or damage.

The following are classed as misuse or abuse:

- Any use or application not described in this owner's manual.
- Disregard for any instructions – especially safety instructions – given in this owner's manual.
- When a fault which might affect the safety is not repaired immediately, thereby affecting the functionality and safe operation of the outboard engine.
- Any modification to or removal of safety features.
- The use of spare parts or accessories that are inappropriate or not approved by Neander Shark.
- Operation in closed or poorly ventilated areas without sufficient measures for ventilation and exhaust gas removal.

Rating plate

The identification of the outboard engine can be found on the rating plate (1), which is located on the left-hand side of the engine block.

The serial number and year of manufacture are engraved next to the rating plate.

You will be asked for the information on the rating plate, as well as the serial number, for example, when contacting customer service, in order to ensure the correct identification of outboard engine components.

The rating plate contains the following information:

- Name and address of the manufacturer
- Website of the manufacturer
- Model name
- CE marking

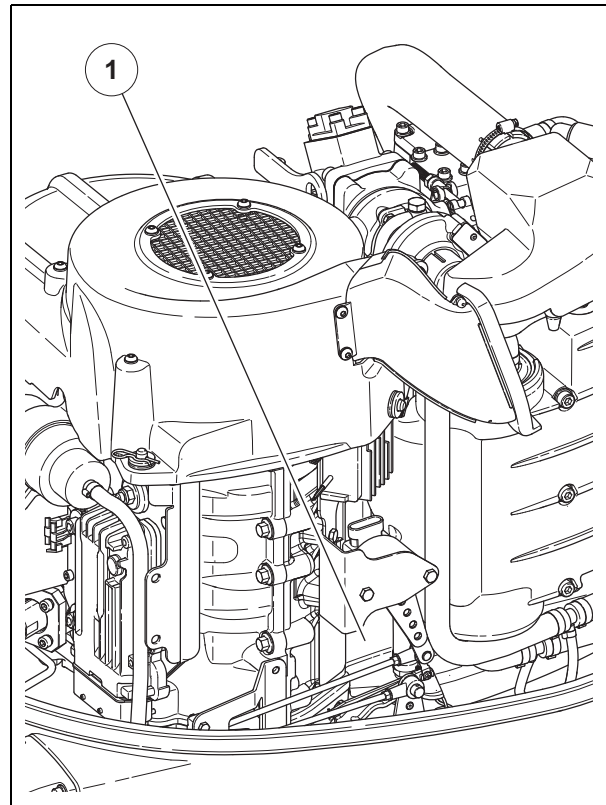

Scope of delivery

The outboard engine is delivered in a wooden shipping crate including padding and fixing hardware.

Check the scope of delivery in accordance with the delivery documents.

Upon receipt, ensure that all of the parts are present and in perfect condition. Do not operate the outboard engine if there are any signs of damage. Refer to your dealer, or contact Neander Shark directly.

The Dtorque 111

Area of application

The Dtorque 111 was developed by Neander Shark for industrial use and commercial applications in particular.

The intended areas of application include:

- fishing
- workboats
- charter operations
- official bodies (police, customs, marine)
- rescue boats
- tender boats

Main features and advantages

The Dtorque 111 offers a range of special features and advantages:

- excellent operational safety
- durability and reliability
- powerful drive
- low consumption
- low vibration level
- problem-free availability of diesel
- no need for explosion-proof storage of fuel

Patented dual crankshaft design

As all engine vibrations are transferred directly to the boat via the transom, the vibration characteristics of the outboard engine itself are extremely important.

The Dtorque 111 possesses two counter-rotating crankshafts. This patented dual crankshaft design eliminates the rolling moment and most of the inertia forces and thus strong vibrations typically found in conventional diesel engines. The counter-rotating crankshafts ensure practically vibration-free and smooth running of the outboard engine.

Thanks to its comfortable and smooth running behavior, the Dtorque 111 can be operated with ease from the helm and without any effort using the tiller handle.

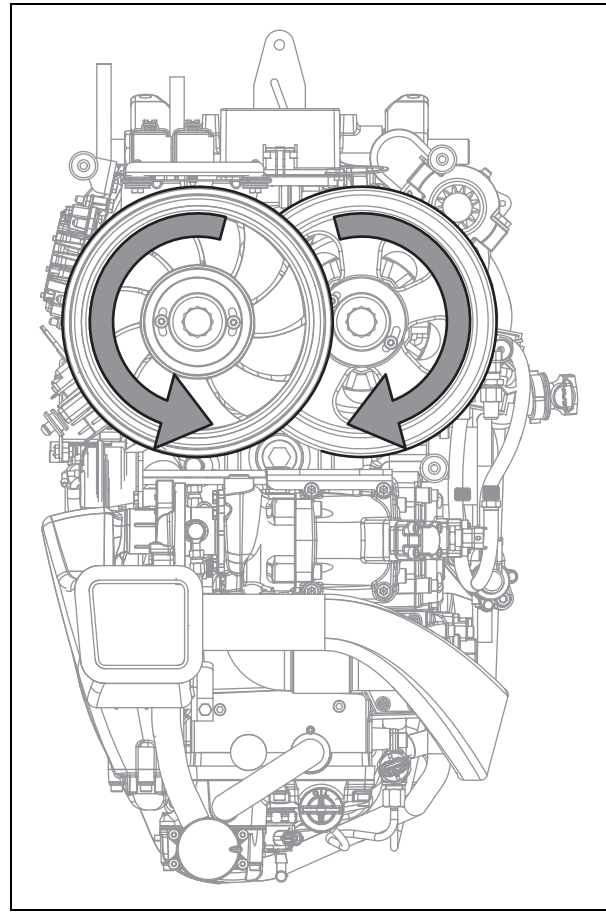

The counter-rotating crankshafts (2) are connected by gears (1).

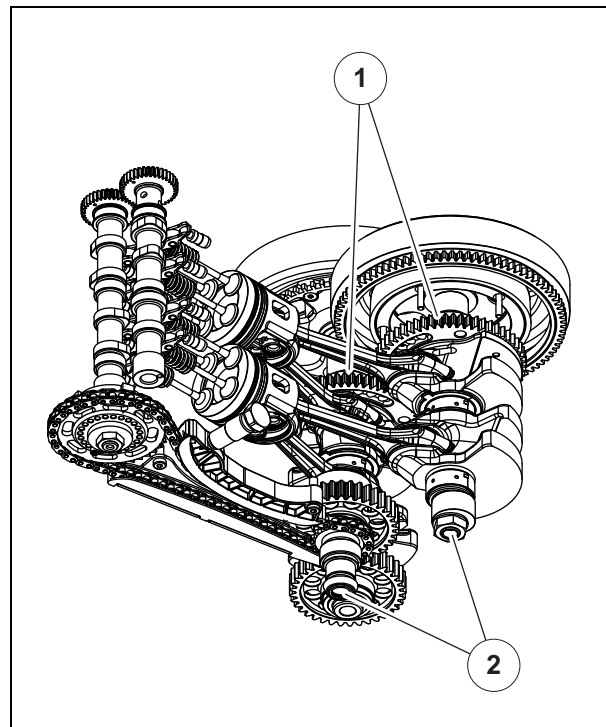

Patented lateral guidance of the piston thanks to the spaceball

The lateral piston guidance is key to the dual crankshaft design with offset crank mechanism and two connecting rods. The patented *spaceball* was developed in order to prevent piston rocking in the cylinders, thereby increasing the useful life of the engine.

The spaceball (2) joins the connecting rods (1) and the piston (3). It prevents lateral movement of the piston, ensuring instead that it follows the cylinder axis. This special suspension constricts the movement of the crosswise connecting rods, thereby virtually eliminating the side forces of the piston and ensuring low-wear travel of the pistons in the cylinders.

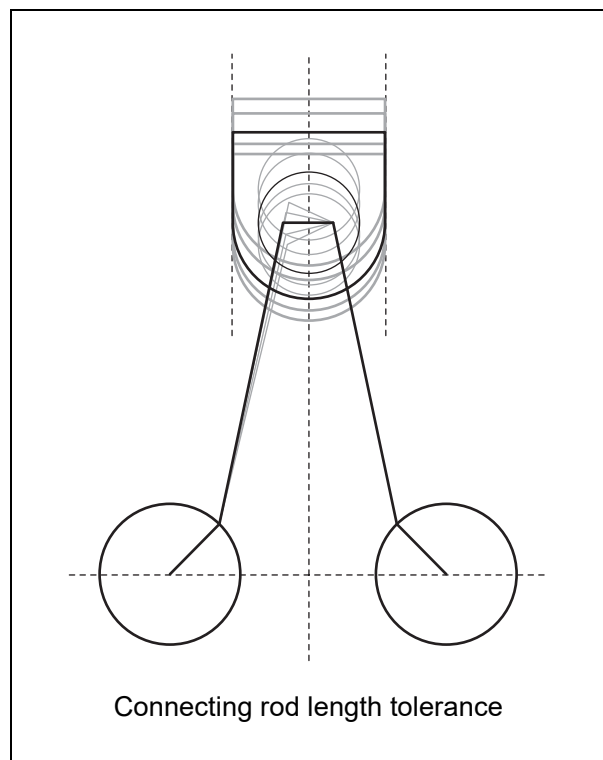
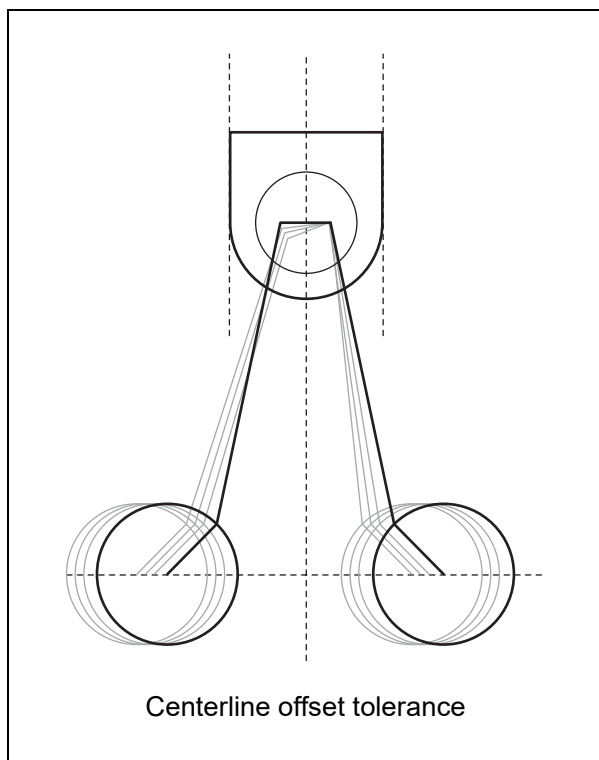
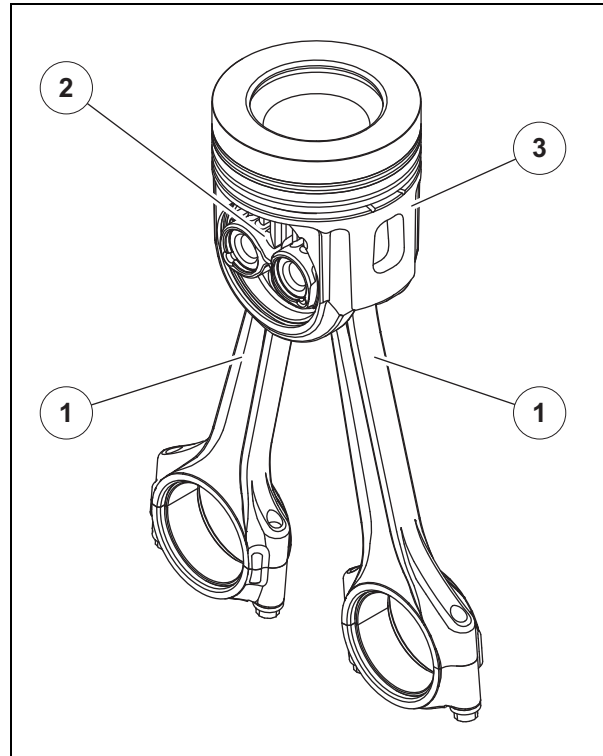

Robust and easy-to-maintain cylinder block

The aluminum design of the cylinder block with a closed deck offers weight advantages while making it robust and easy to service.

The cylinder head, block and bedplate are joined by through bolts (1), which ensures optimum compression load balance. In addition, the calibrated oil damping of the threaded joints provides stability: a well-proven design from the high-performance marine and automotive engine segment.

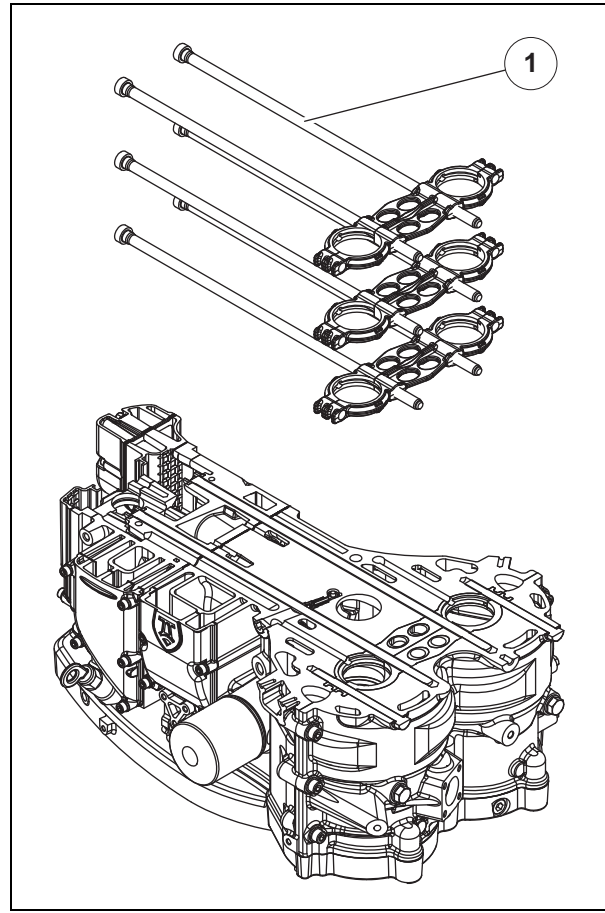

Durability and efficiency

The cost efficiency of diesel engines is particularly noticeable after long run times and service lives.

In order to keep servicing and maintenance costs down, the Dtorque 111 has a timing chain (5) joining the crankshaft (4) and the camshaft (2) instead of a toothed belt, which is liable to wear.

For the greatest possible efficiency, the Dtorque Turbo Diesel operates using four-valve technology (3) and two overhead camshafts (2). This optimizes burning, which saves fuel.

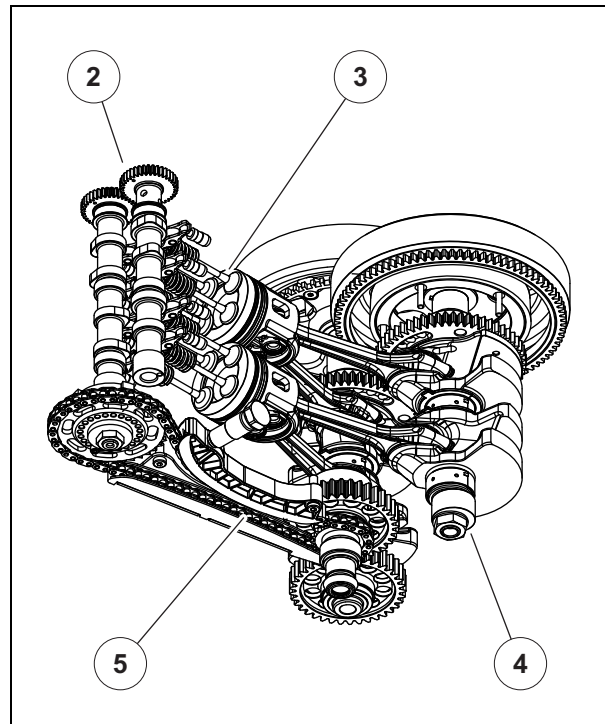

Components

Overview of assemblies

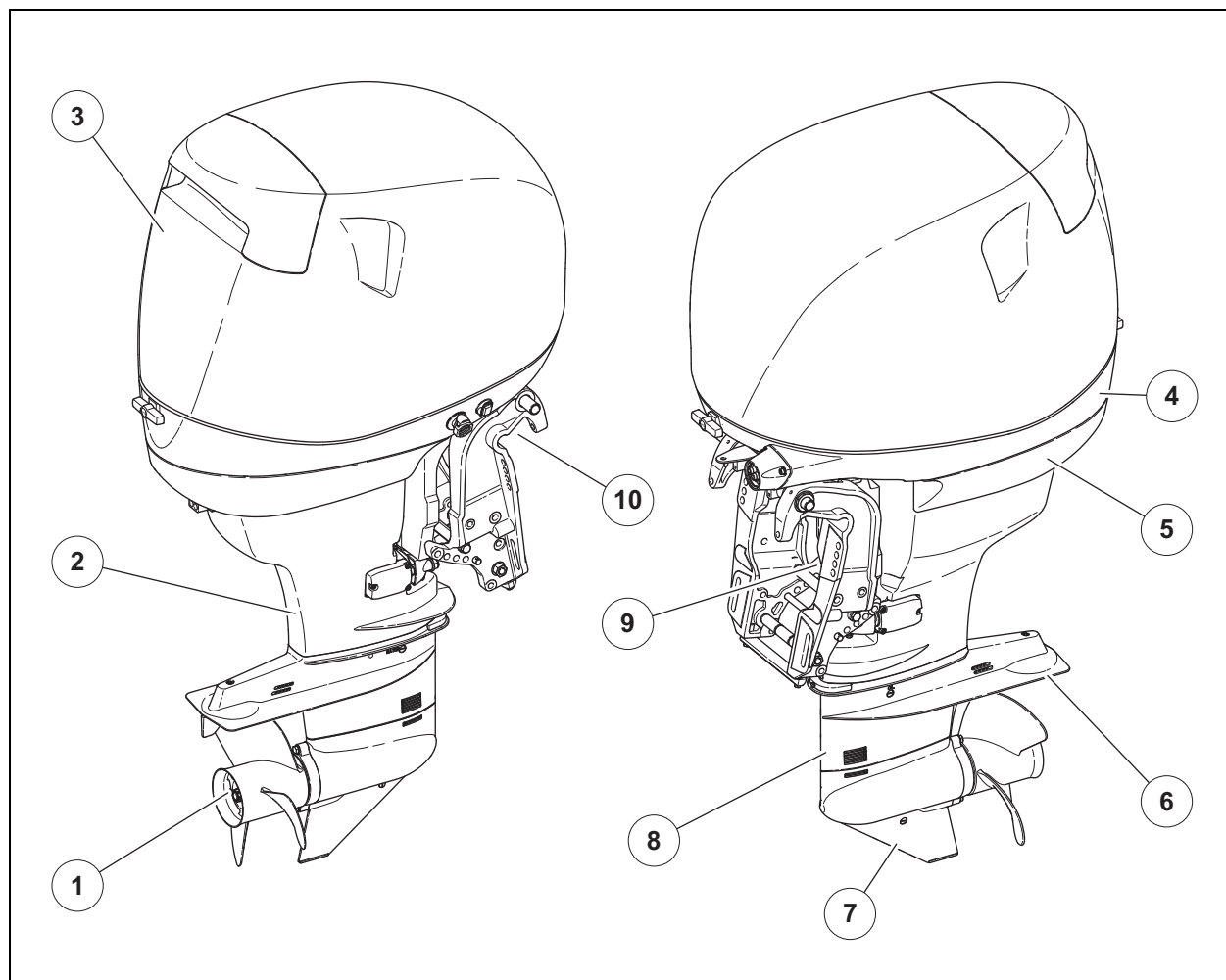

1 Propeller

2 Upper shaft

3 Upper cowling

4 Lower cowling

5 Casing

6 Anti-cavitation plate

7 Fin

8 Leg

9 Power trim

10 Transom

Propeller

A range of different propellers made of aluminum or stainless steel are approved for use with the Dtorque 111 (see page 178). The propeller can be replaced with an identical or any other approved model at any time.

Cooling water and exhaust gases are expelled below the waterline via openings in the propeller. When dynamic pressure builds up at the outlets during reversing, two holes on the back of the upper shaft serve as exhaust (see page 31).

Anti-cavitation plate

The anti-cavitation plate (also referred to as anti-ventilation plate) prevents air from the surface of the water to reach the propeller.

Ventilation is when air from the surface of the water or exhaust gas is sucked into the propellers. This reduces the load on the propeller, causing the engine to overspeed and thrust to be lost. At the same time, the propeller spins too fast and causes cavitation, which in turn reduces the load even more so that the propeller eventually loses any traction in the water and all thrust is lost. This situation remains until the propeller speed is reduced by throttling until the air bubbles come off the surface and rise to the top of the water.

When oriented correctly and installed at just the right depth, the anti-cavitation plate can prevent this effect from happening.

Transom

The transom anchors the outboard engine securely to the boat by means of four bolts that pass through the transom and into the transom. The two brackets at the top of the transom are for aligning and temporarily fixing the outboard engine in place during installation and removal.

Trab trim

The trab trim, located directly below the anti-cavitation plate, also acts as a sacrificial anode. The sacrificial anode is made out of zinc and is designed to prevent corrosion on other parts of the outboard engine made of more noble metals. The trab trim must be replaced when necessary due to corrosion.

Power trim

The power trim is an electrohydraulic drive used to tilt the outboard engine. The power trim is located between the engine casing and the transom.

The power trim is used to adjust the position of the outboard engine (and thereby the angle of the propeller to the surface of the water) at any time, even during travel, when the position of the boat changes due to load, speed or waves.

During travel, operation should occur via a switch on the control box (see page 37) or tiller handle (see page 33). Alternatively, the power trim can also be used via the switch on the outboard engine (see page 31) when out of the water, for example.

Overview of the engine block

Right-hand side of the engine

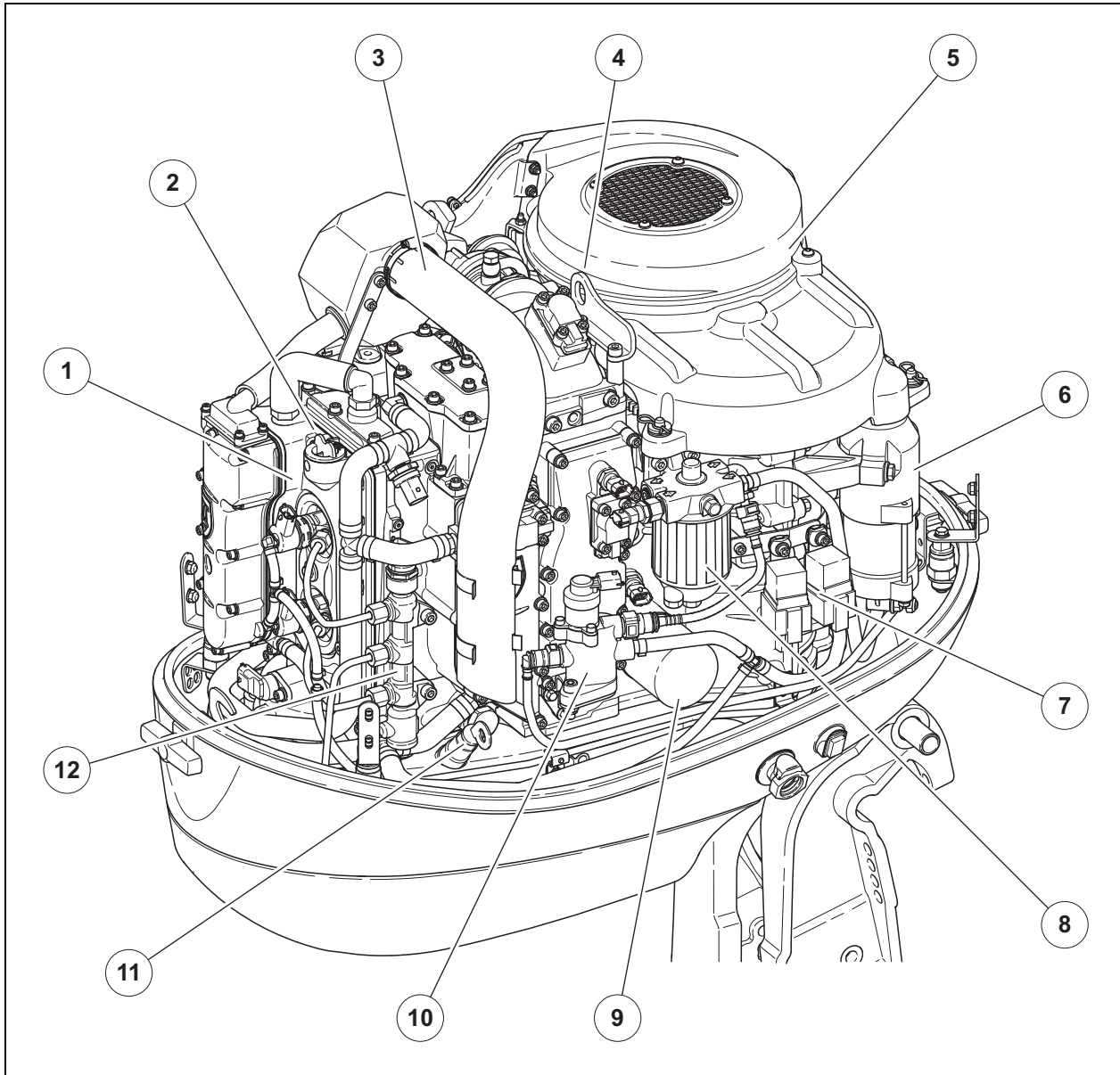

- | | |
|---|------------------------------------|
| 1 Crank case breather | 7 Relay for power trim |
| 2 Engine oil filling hole | 8 Fuel filter with water separator |
| 3 Air intake manifold | 9 Engine oil filter |
| 4 Anchor point for lifting gear | 10 Fuel control unit |
| 5 Flywheel fan guard for flywheel fan and flywheels | 11 Oil dipstick |
| 6 Starter motor | 12 Common rail unit |

Left-hand side of the engine

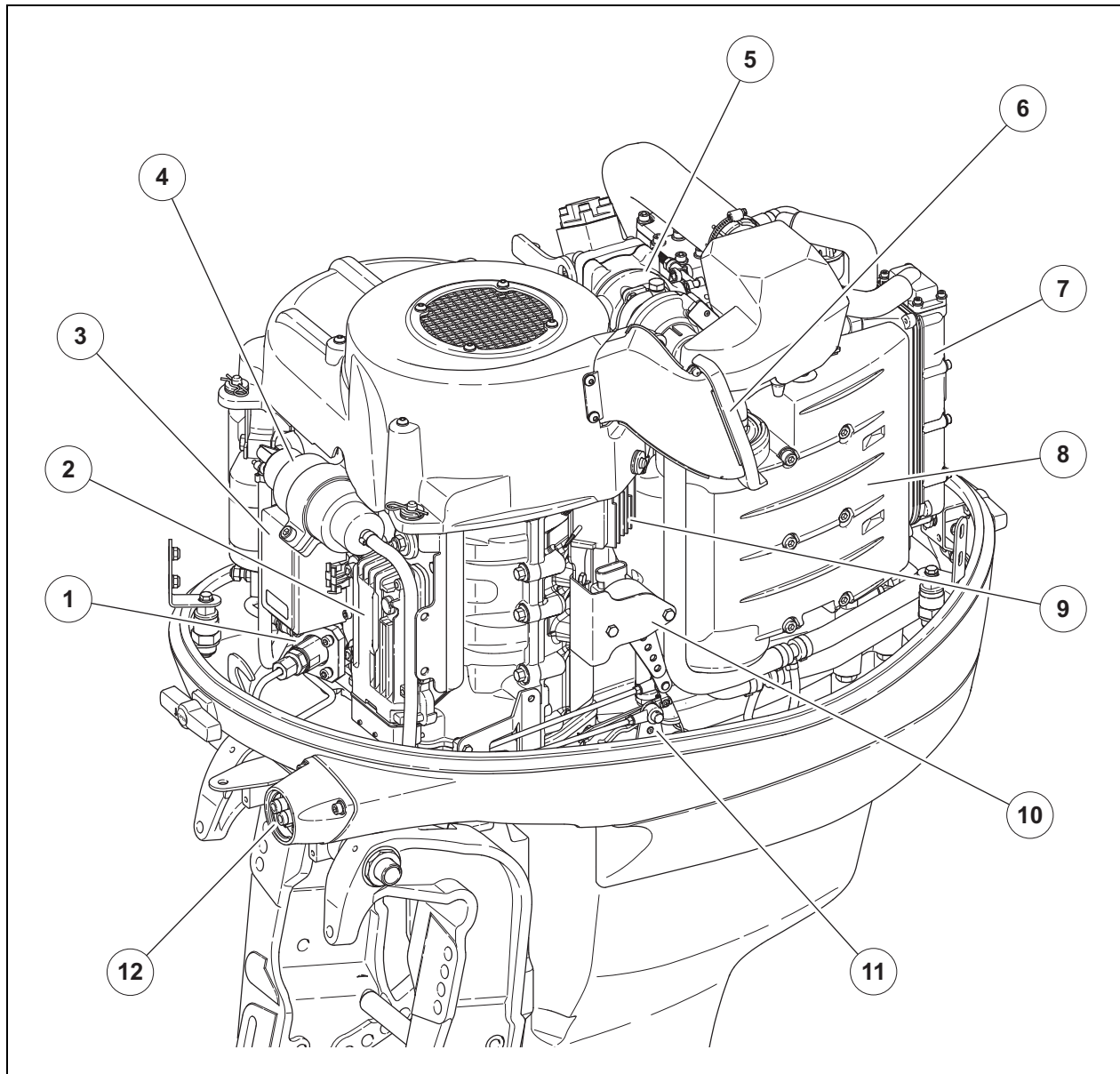

- | | |
|--|---|
| 1 High-pressure fuel pump | 7 Oil separator |
| 2 Electronic control unit (ECU) | 8 Intercooler |
| 3 Fuse box with fuses, glow plug relay and starter relay | 9 Alternator regulator |
| 4 Electric fuel pump | 10 Electronic throttle position sensor |
| 5 Turbocharger | 11 Shift lever |
| 6 Air outlet of flywheel fan | 12 Duct for electrical leads and control cables |

Fuel system

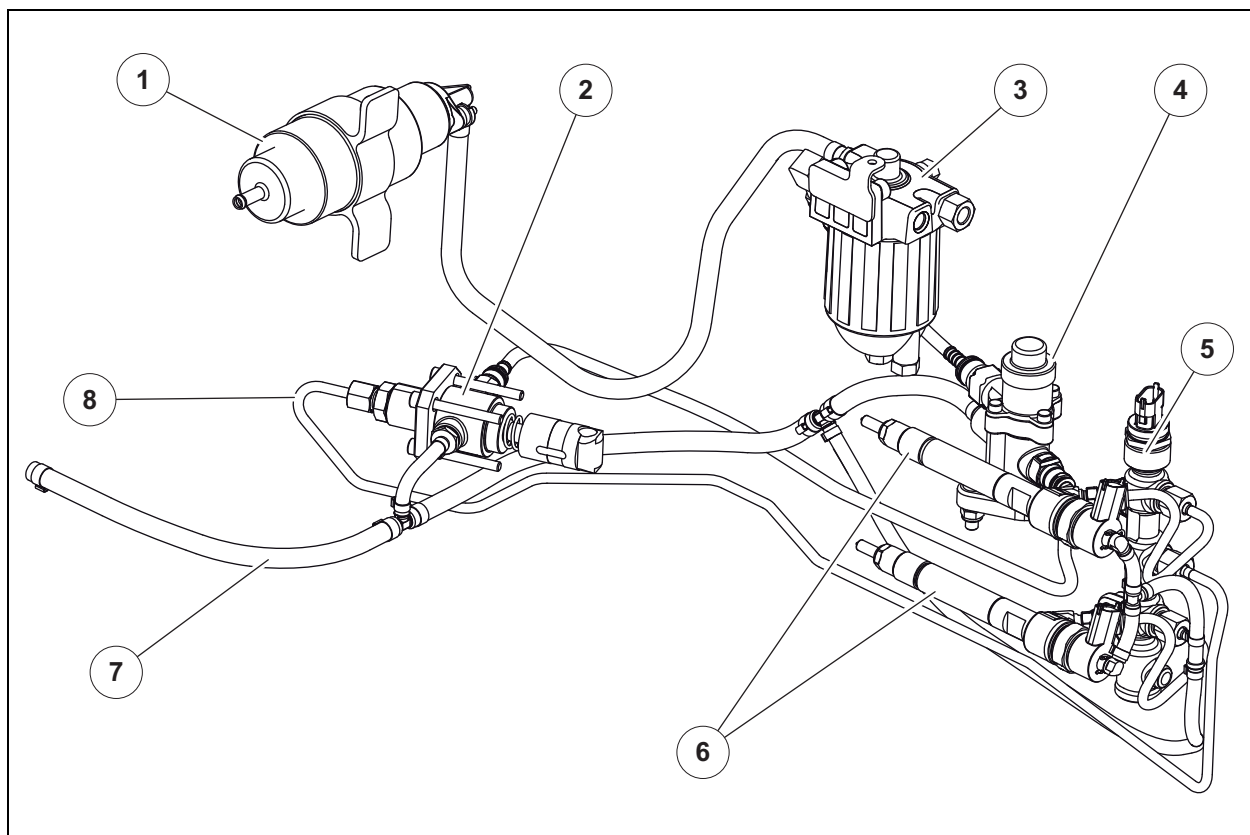

- 1 Electric fuel pump
- 2 High-pressure fuel pump
- 3 Fuel filter with water separator
- 4 Fuel control unit
- 5 Common rail unit
- 6 High-pressure injection nozzles
- 7 Plastic low-pressure fuel line
- 8 High-pressure fuel line (metal)

Fuel circuit

The electric fuel pump (1) draws the fuel from the fuel tank through the fuel filter with water separator (installed outside of the engine).

The fuel is forced through the fuel filter (3) and into the fuel control unit (4). There, the mechanical pressure relief valve opens, allowing fuel to flow back into the tank. The pre-feed pressure is regulated by the pressure relief valve.

The fuel feed amount is regulated by the uncontrolled electric fuel pump (1).

The fuel control unit (4) output is controlled according to the nominal pressure demand at the high-pressure sensor on the common rail unit (5). The correct amount of fuel then flows into the high-pressure fuel pump (2), which compresses it to the actual pressure demand.

The electronic high-pressure sensor integrated in the common rail unit has a maximum operational range of $\leq 1,800$ bar.

Fuel which does not enter the high-pressure pump compressor flows back into the fuel tank via a return line.

The two high-pressure injection nozzles (6) connected to the high-pressure circuit are time-controlled and inject the precalculated amount of fuel into the combustion chamber. A small amount of fuel bypasses the valve, which is then returned to the fuel tank via the return line. A ball check valve protects the high-pressure injection nozzles from pressure peaks from the return line.

Control

The electronic throttle position sensor (see page 28) adjusts the power demand to the engine from 0% to 100% according to the control cable operation.

An electronic pickup determines the engine speed and the position of the pistons with respect to the top dead center (TDC) by picking up the pulses from the annular gear on the crankshaft flywheel.

Another electronic pickup determines the phases of the cylinders by picking up the pulses from the camshaft.

This sequence remains the same throughout all of the different load conditions of the engine (idling, partial load, full load). Only the value of the high pressure and the duration and timing of the injection vary.

When idling, the constant pre-feed rate is approx. 80 to 100 times the consumption, and under full load it is approx. 6 to 8 times.

All of the functions of the engine are controlled by the electronic control unit (ECU, see page 28).

Controls, connectors and indicators

You should be able to recognize and operate the following controls, connectors and indicators in order to control the outboard engine.

Right-hand side of the engine

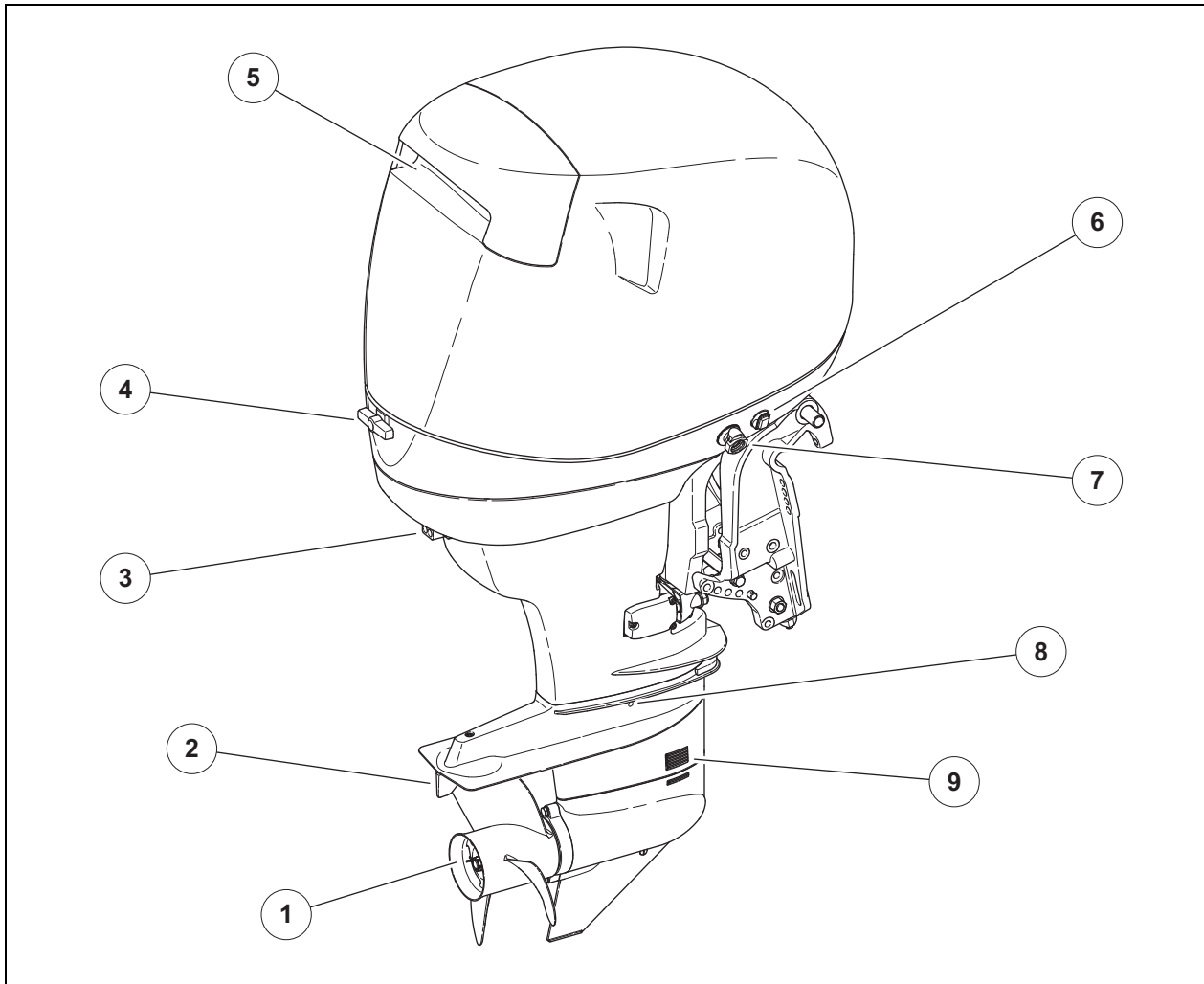

- | | |
|--|--|
| 1 Exhaust (through the propeller) | 6 Trim switch of power trim |
| 2 Trab trim, also acts as sacrificial anode | 7 Flushing connector for fresh water |
| 3 Outlet for exhaust when reversing and outlet for cooling water | 8 Alternative flushing connector for fresh water |
| 4 Back cowling lock knob | 9 Cooling water inlet |
| 5 Back air inlet | |

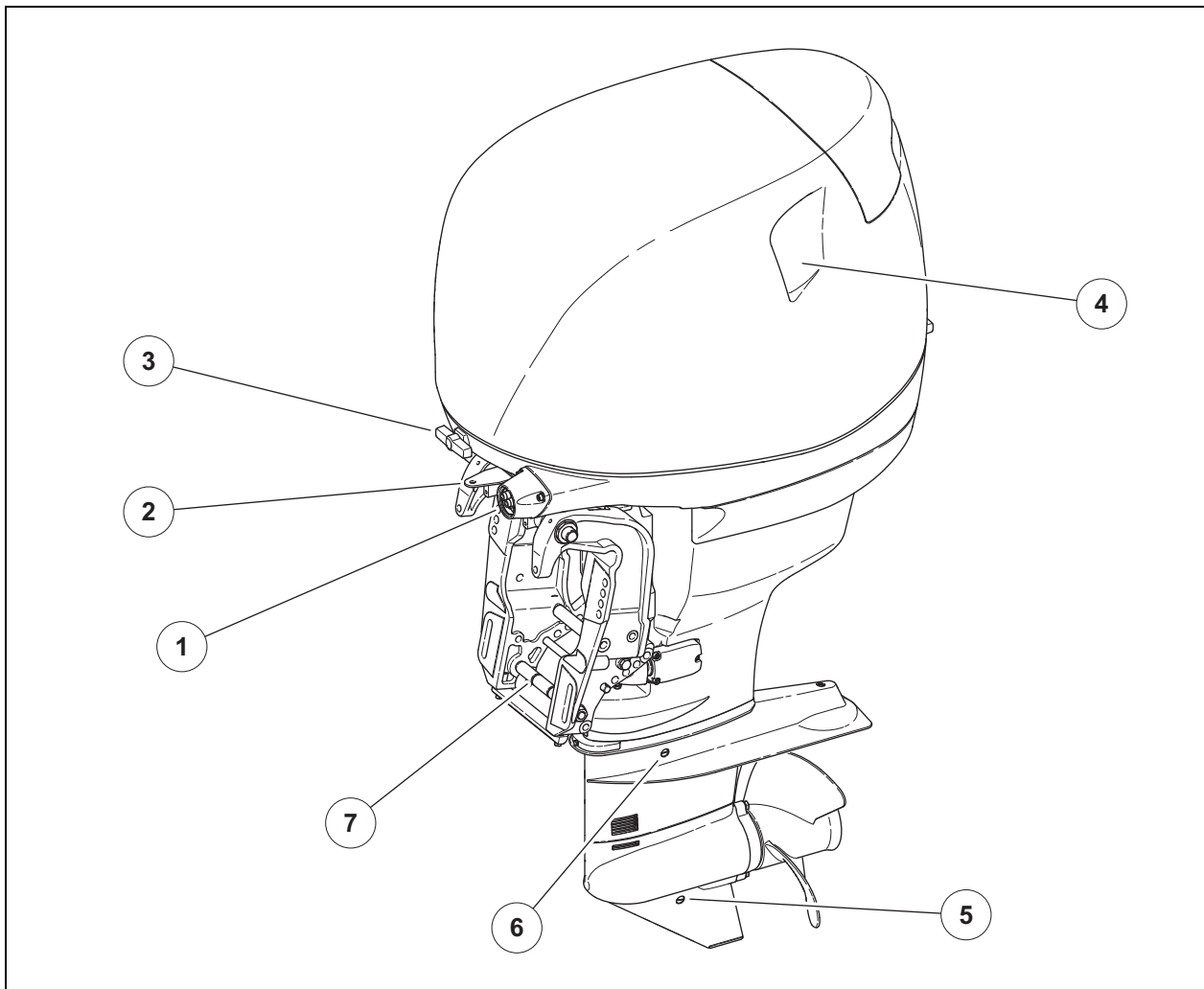
Left-hand side of the engine

- 1 Duct for electrical leads and control cables
- 2 Mount for steering linkage
- 3 Front cowling lock knob
- 4 Air outlet of flywheel fan
- 5 Drain hole Transmission oil
- 6 Ventilation hole for draining transmission oil
- 7 Trim pin (lower stop)

Tiller handle (optional)

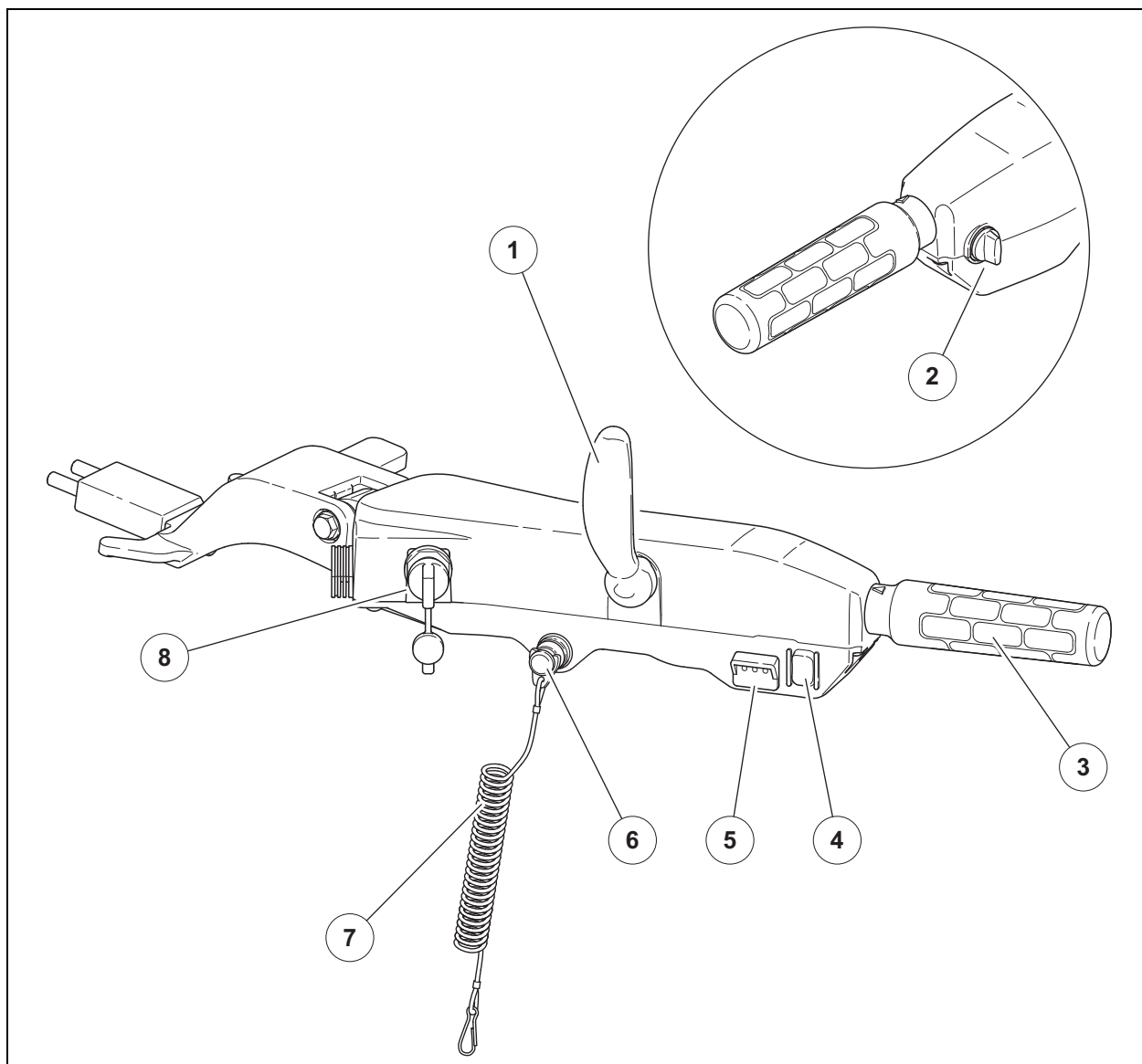

- 1 Shift lever for disengaging the transmission and selecting between forward and reverse gear
- 2 Adjusting screw for throttle grip resistance
- 3 Throttle grip
- 4 Trim switch of power trim
- 5 Indicators
- 6 Stop button (quick stop)
- 7 Kill switch lanyard with clip
- 8 Ignition switch with ignition key

Ignition switch

The ignition switch is protected against splash water by a protective cap (2). The ignition key can be inserted once the protective cap has been removed.

For protection against splash water, a protective cap (1) can be fitted over the ignition key once it is inserted. This protective cap can be left on the ignition key at all times.

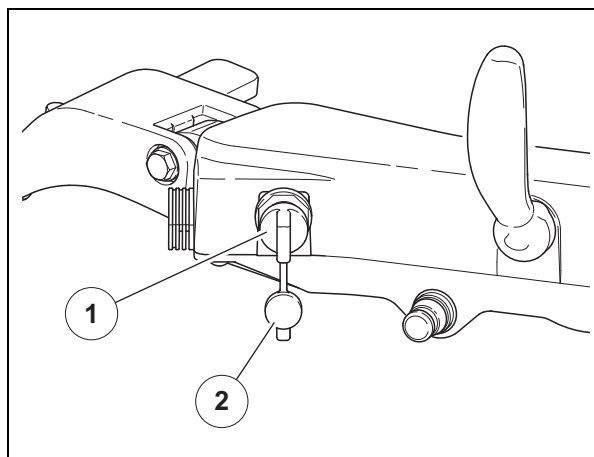

With the ignition key inserted, the ignition switch can be moved into one of three positions:

- Off (3): The outboard engine is switched off and does not receive any power.
- On (4): The outboard engine is switched on and is receiving power.
- Start (5): The starter motor is running.

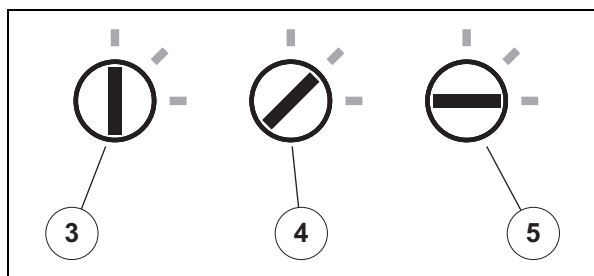

Stop button

The stop button (6) has an open electrical contact that prevents the engine from being started. To close the contact, the stop button must be pulled out against the resistance from a spring. This is done by inserting the clip (7) on the end of the kill switch lanyard (8). Pulling out the clip automatically opens the electrical contact, which cuts the engine out and prevents it from being restarted.

The kill switch lanyard can be attached to the skipper's body. If the skipper goes overboard, the clip attached to the kill switch lanyard is pulled out of the stop button, which immediately cuts off power to the outboard engine.

The second engine kill switch lanyard with a clip (provided) must be kept within easy reach. It will make it possible for the engine to be restarted even if the skipper goes overboard with the first kill switch lanyard.

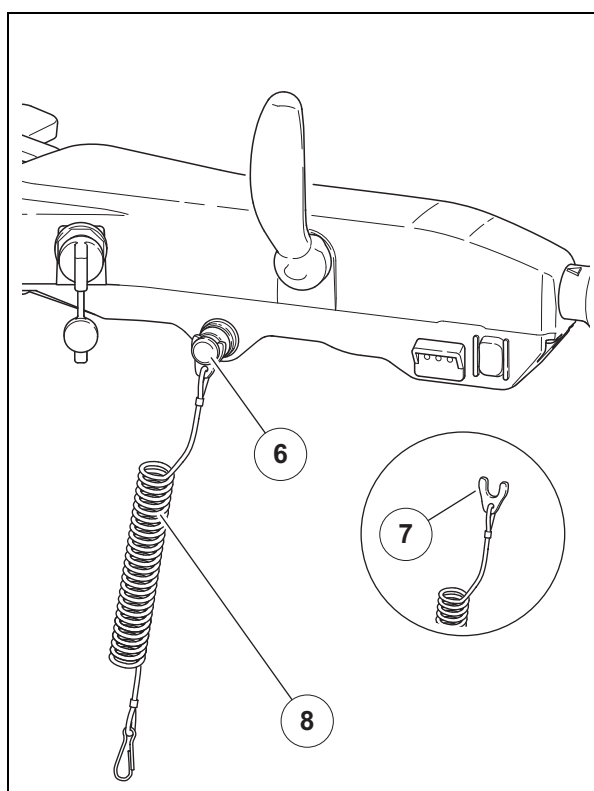

Shift lever

The shift lever shifts between neutral (**N**), forward and reverse. Move the shift lever as far as it will go in the corresponding direction to go forward or reverse.

The outboard engine can only be started up with the shift lever in the neutral position. This prevents the boat from moving as soon as the outboard engine is started.

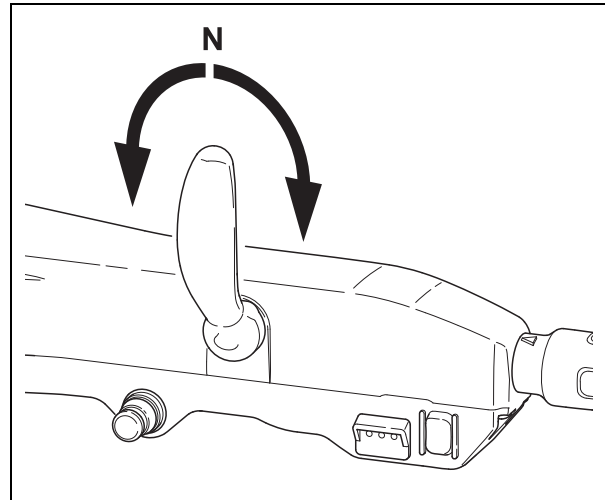

Throttle grip

The throttle grip is used to vary the speed of the engine. Turning the grip counterclockwise increases the engine speed; turning it clockwise reduces the engine speed.

The resistance of the throttle grip can be set with the adjusting screw (1). This will keep the throttle grip in the selected position and prevent it from dropping down to the lowest engine speed when releasing it. To reduce the engine speed, you will need to turn the throttle grip manually counterclockwise.

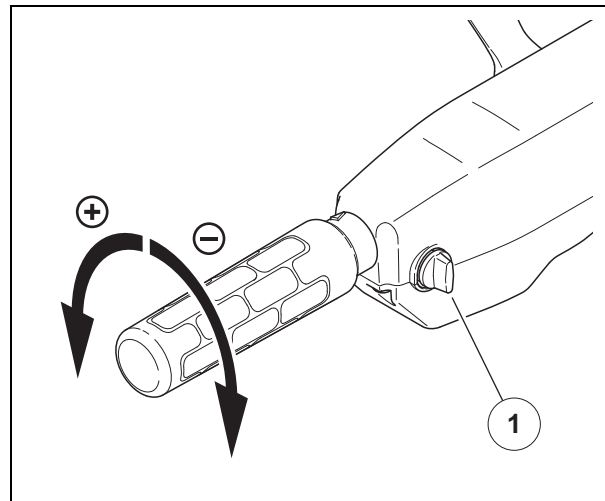

Trim switch

The trim switch switches the power trim relays for tilting the outboard engine.

The trim switch has two functions:

- Tilt up (2)
- Tilt down (3)

Releasing the trim button automatically stops the tilting movement.

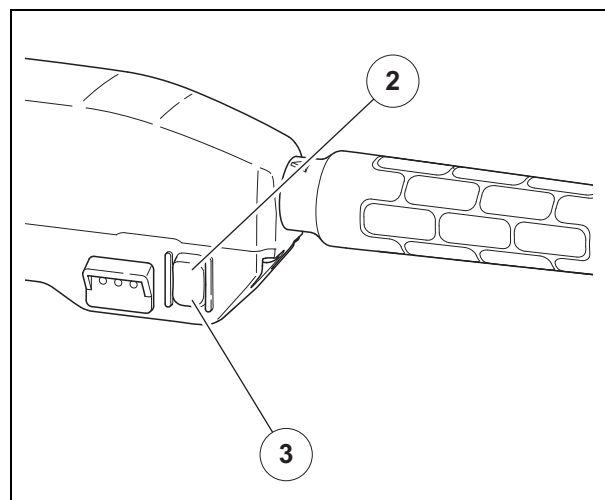

Indicators

The three indicators convey various information when the outboard engine is switched on using the ignition key.

- 1 Engine indicator (MIL):
Illuminates for approx. 1 second after switching on the ignition (testing function of indicator and acoustic signal); continuously illuminated in the event of a fault (e.g., water in fuel).
- 2 Pre-glow indicator:
Lights during the pre-glow time; start the engine as soon as the indicator goes off (see page 85).
- 3 Ignition and charging indicator:
Illuminates while the ignition is on; turns off when the engine speed is high enough for the alternator to supply power (approx. 800 min^{-1}). The battery starts charging at approx. $1,000 \text{ min}^{-1}$.

An acoustic signal sounds whenever the engine indicator (1) is illuminated.

When the engine indicator is continuously illuminated due to a fault, you can display the fault code (see page 109).

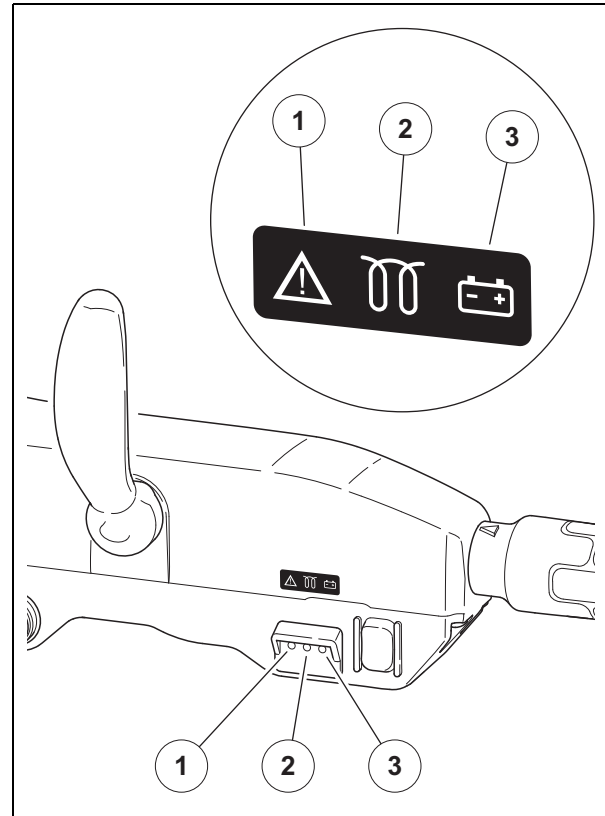

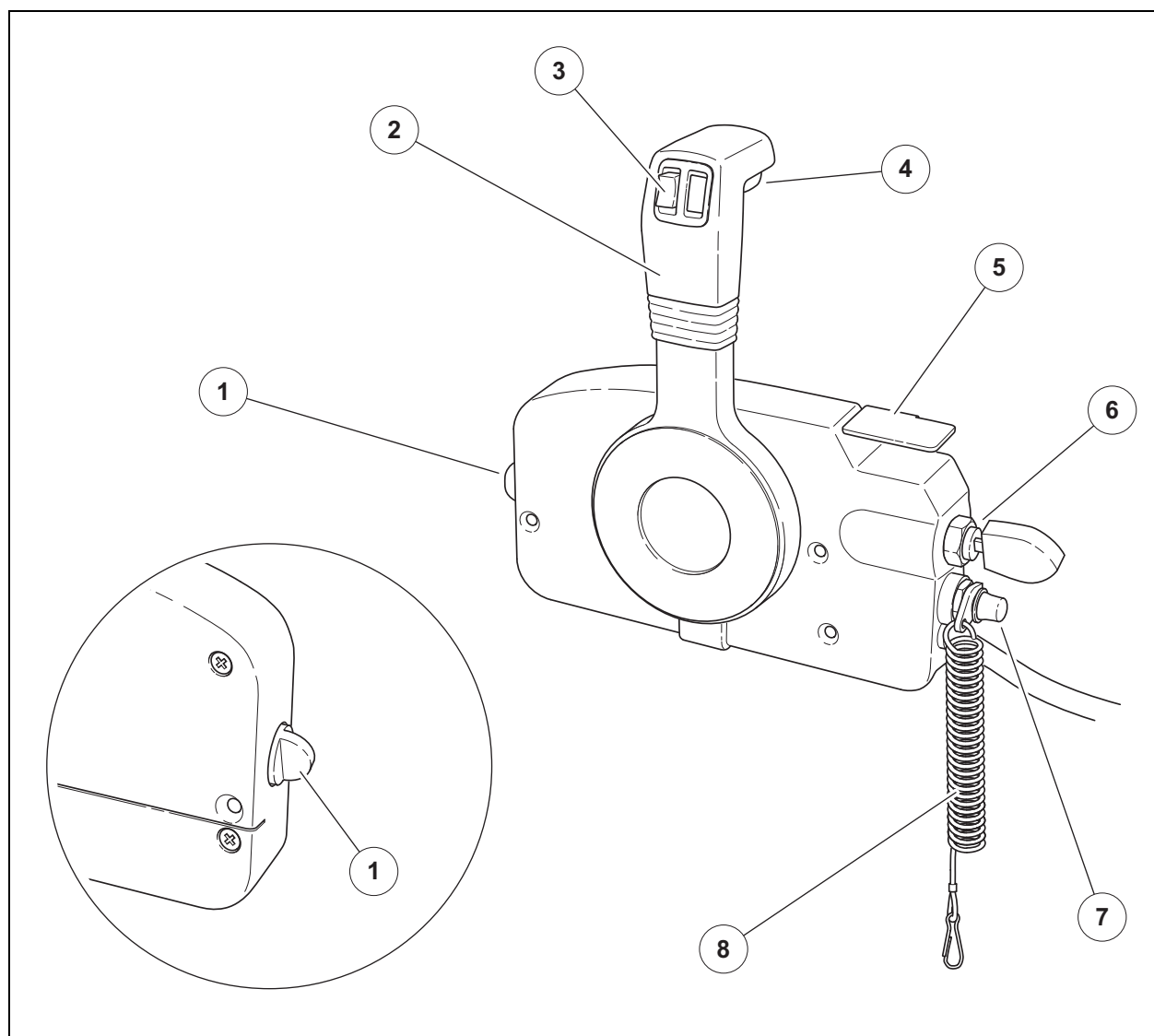
Control box (optional)

- 1 Adjusting screw for shift and throttle lever resistance
- 2 Shift and throttle lever for engaging forward or reverse gear and selecting the travel speed
- 3 Trim switch of power trim
- 4 Button for releasing the neutral lock
- 5 Throttle lever for warm-up
- 6 Ignition switch with ignition key
- 7 Stop button (quick stop)
- 8 Kill switch lanyard with clip

Ignition switch

The ignition switch is protected against splash water by a protective cap. The protective cap has a slot for inserting the ignition key (1).

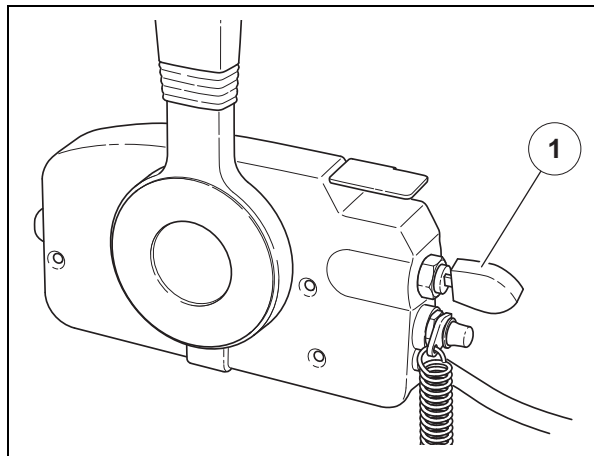

With the ignition key inserted, the ignition switch can be moved into one of three positions:

- Off (2): The outboard engine is switched off and does not receive any power.
- On (3): The outboard engine is switched on and is receiving power.
- Start (4): The starter motor runs.

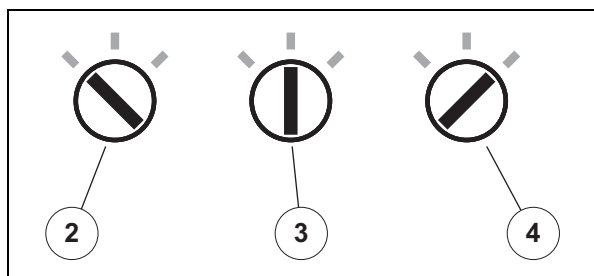

Stop button

The stop button (6) has an open electrical contact that prevents the engine from being started. To close the contact, the stop button must be pulled out against the resistance from a spring. This is done by inserting the clip (7) on the end of the kill switch lanyard (5). Pulling out the clip automatically opens the electrical contact, which cuts the engine out and prevents it from being restarted.

The kill switch lanyard can be attached to the skipper's body. If the skipper goes overboard, the clip attached to the kill switch lanyard is pulled out of the stop button, which immediately cuts off power to the outboard engine.

The second engine kill switch lanyard with a clip (provided) must be kept within easy reach. It will make it possible for the engine to be restarted even if the skipper goes overboard with the first kill switch lanyard.

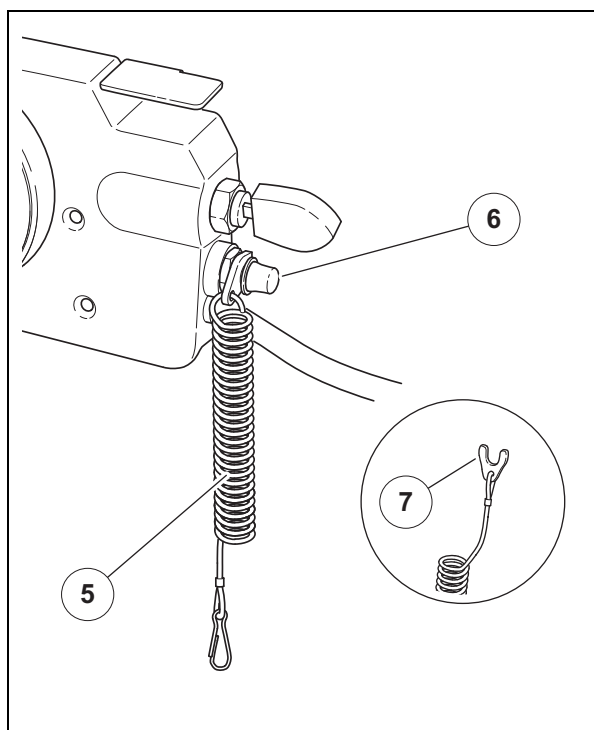

Shift and throttle lever

The shift and throttle lever is used to shift between neutral (**N**), forward and reverse and to vary the speed of the engine.

Move the shift lever in the corresponding direction to go forward or reverse. The further the shift and throttle lever is moved, the higher the speed of the engine.

The adjusting screw (2) is used to adjust the resistance felt when moving the shift and throttle lever.

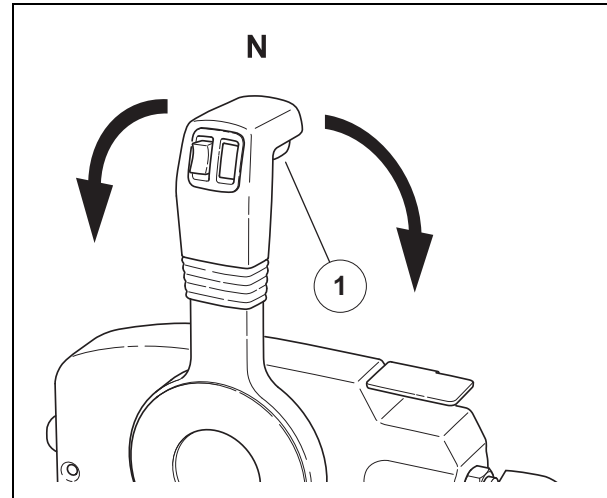

The shift and throttle lever can only be moved forward or backward out of the neutral position while the button for releasing the neutral lock (1) is pressed. This prevents the shift and throttle lever from being accidentally actuated, such as when bumped into by people on a rocking boat.

The outboard engine can only be started up with the shift and throttle lever in the neutral position. This prevents the boat from moving as soon as the outboard engine is started.

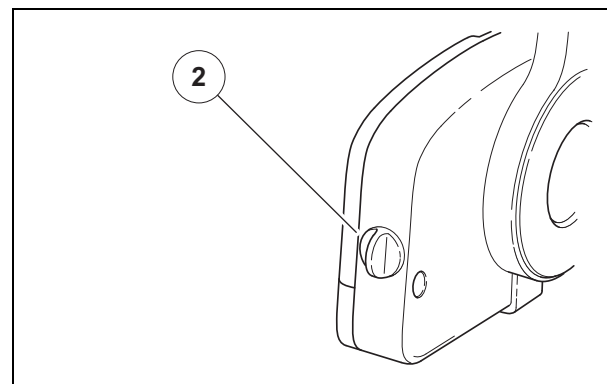

Throttle lever for warm-up

The throttle lever for warm-up (4) is used to increase the speed without engaging a gear. The lever will remain in the selected position. This makes it possible to operate the outboard engine at a low speed during warm-up after a cold start (see page 78).

The throttle lever for warm-up can only be moved with the shift and throttle lever (3) in the neutral position. Likewise, the shift and throttle lever can only be moved when the throttle lever for warm-up is closed.

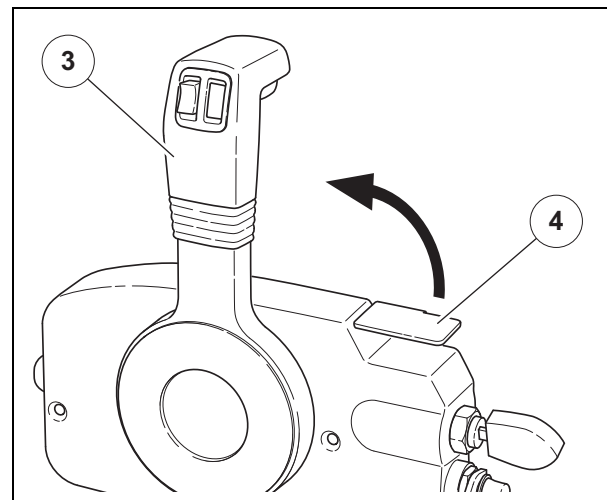

Trim switch

The trim switch at the top of the shift and throttle lever switches the power trim relays for tilting the outboard engine.

The trim switch has two functions:

- Tilt up (1)
- Tilt down (2)

Releasing the trim button automatically stops the tilting movement.

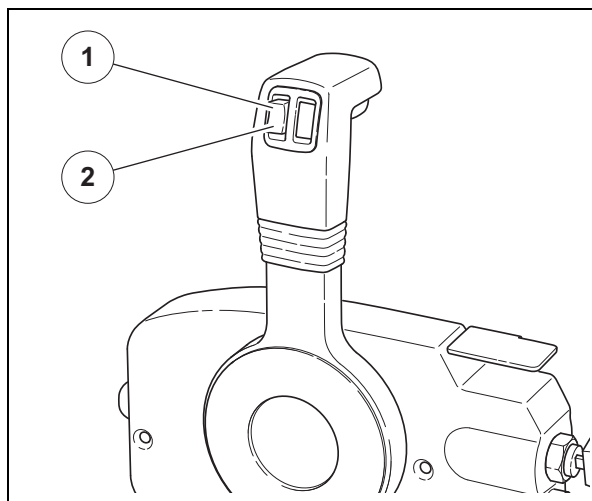

Installation

Unpacking

NOTICE

Danger of damage.

The outboard engine can be damaged if it is not removed correctly from its packaging.

Be extremely careful when unpacking and ensure that no part of the outboard engine is damaged by tools (e.g., knives, pliers or screwdrivers).

The outboard engine is packaged in a stable shipping crate made of wood for delivery. Smaller parts and accessories are packaged separately in boxes or bags. Additional devices can be delivered in the same packaging or separately depending on the scope of delivery.

Observe the following instructions when unpacking the engine:

- Inspect the shipping crate and all packaging for external damage.
- Check the delivery for missing parts and damage. Inform the supplier immediately if you identify any damage or missing items.
- Pay special attention to small parts and individual parts in the packaging materials.
- If possible, store the dismantled shipping crate (along with all the screws, nails and padding) in a safe, dry place for future reuse.
- After inspecting the delivery for missing parts and damage, any packaging materials or padding should be disposed of in accordance with the legal guidelines.

Transporting the packaging



WARNING

Danger of injury due to weight and asymmetrical load.

The outboard engine is extremely heavy (at least 175 kg). The center of gravity is not located at the center of the shipping crate.

- The shipping crate should only be moved using a forklift or pallet truck.
- The shipping crate should not be lifted from the top or moved using a crane.
- Be aware of the center of gravity as indicated on the outside of the shipping crate.

- Using a forklift or pallet truck, move the shipping crate to a suitable location where all sides are accessible.
- Place the shipping crate on a solid surface which will not tip over the outboard engine once the outboard engine is removed from its fixed position inside the crate.
- Move the transport vehicle out of the working area and inspect the shipping crate for damage.

Removing the packaging

The sides and the top of the shipping crate may be joined together using nails or screws.

If so, observe the following instructions when removing the packaging:

- Work in a team of two so that one person can be holding the piece of shipping crate to be removed while the other is unscrewing it or removing the nails.
- Remove all nails or screws using appropriate tools.
- Ensure no nails or screws are left sticking out.
- Remove the top first of all, followed by the four sides, one at a time.
- Place any parts removed from the shipping crate away from any traffic routes.

Lifting from the transport pallet



WARNING

Risk of injury due to heavy weight.

The outboard engine is extremely heavy (at least 175 kg). Only professionals with experience using lifting devices may lift the outboard engine from the transport pallet.

- The outboard engine must only be lifted using a crane or hoist with sufficient lifting capacity.
- Always use appropriate lifting gear for anchoring.
- Only the anchor point (1) under the cowling must be used for lifting the device.

Do not begin lifting the outboard engine until all four sides of the shipping crate have been removed and the outboard engine on the transport pallet is accessible from all sides.

Whenever possible, use a loop to connect to the anchor point (1). If using a shackle, ensure that no parts of the engine can be damaged by the shackle coming into contact with them.

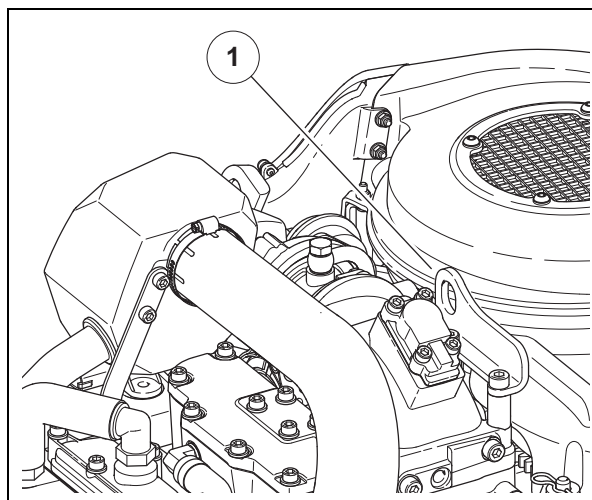

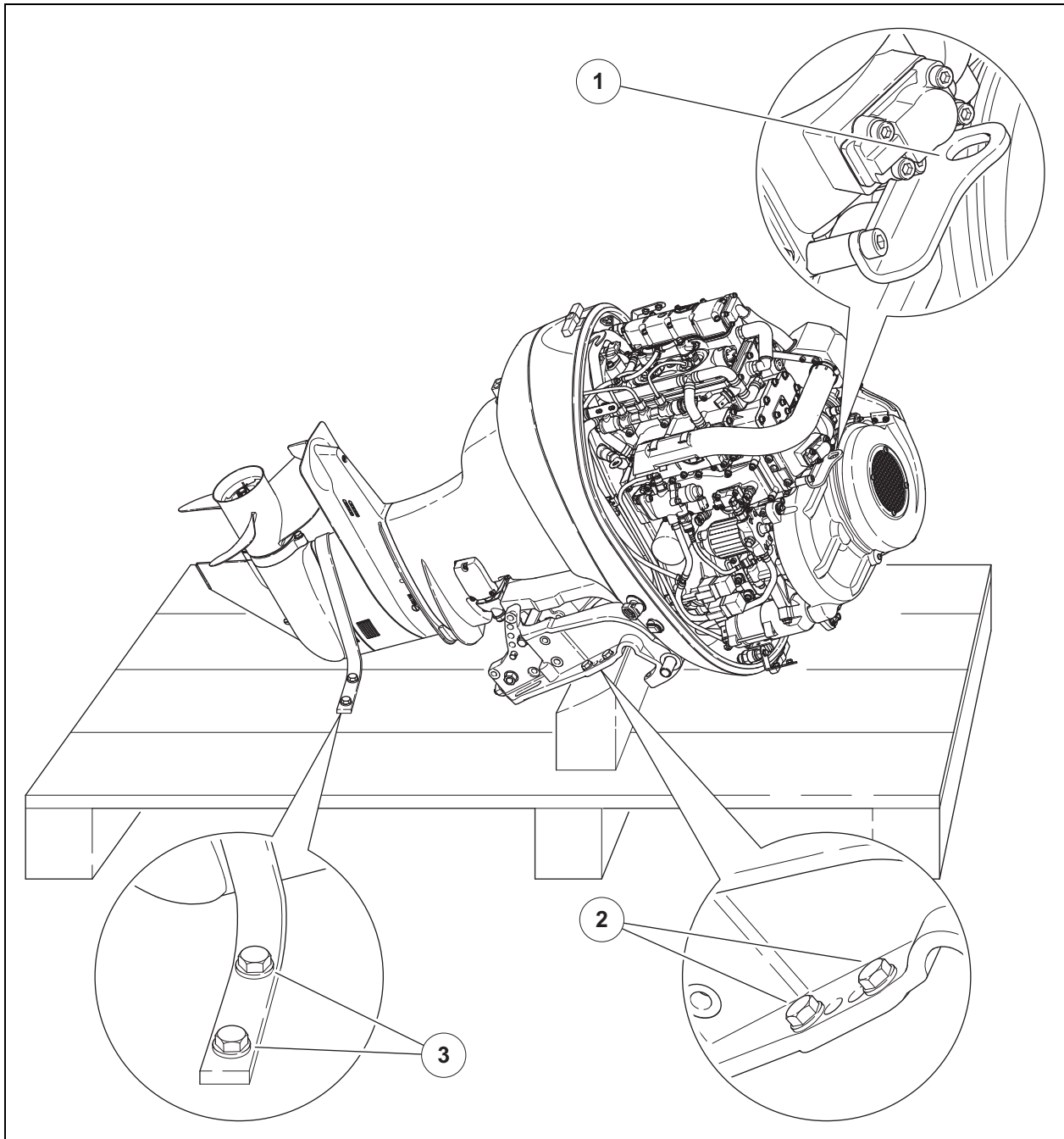

- Remove the cowling (see page 81).
- Attach a loop or any other suitable lifting device to the anchor point (1).
- Completely unscrew the 2 bolts (3) on either side of the fixing strip and remove the fixing strip.
- Unscrew the 2 bolts (2) fixing the transom to the crosspiece on the transport pallet.
- Lift the outboard engine slowly and carefully off the transport pallet.
- Once the outboard engine is vertically suspended, move the transport pallet to one side and out of the way.

Fixing to the boat

Preparations

Checking requirements



WARNING

Hazard due to unauthorized operation.

Before fixing the outboard engine to any boat, check the maximum permissible engine weight and maximum permissible engine power for the boat. Observe the corresponding data for the outboard engine (see *Technical data* from page 171 onwards).

Do not install the outboard engine to the boat if it exceeds the maximum permissible weight or power for that boat. If the engine power is too high for the boat, it can have a negative effect on the core stability of the craft and result in danger during operation.

If you are unsure whether the engine is suitable for the boat or the information is not available, it is essential you contact your dealer or a specialized workshop.



WARNING

Risk of injury due to incorrect installation.

Incorrect installation of the outboard engine or controls can lead to serious injury or damage.

Before you start with the installation, ensure you have the correct tools and sufficient knowledge and experience in attaching outboard engines. If you do not have the right expertise or tools, you must contact your dealer or a specialized workshop to do it for you.

Installation on land



CAUTION

Risk of tipping due to displaced center of gravity.

When attaching the outboard engine to a boat on a trailer or fixed frame on land, the weight of the outboard engine on the back can displace the center of gravity of the entire boat. This means that there is a risk of the trailer, boat or frame tipping backward.

Ensure that there is no chance of tipping.

- Ensure that the trailer or frame is suitable for the extra weight of the outboard engine (see *Technical data* from page 171 onwards).
- Ensure that the trailer, frame or boat cannot be tipped over when the outboard engine is hung, by using supports.

Installation in the water



CAUTION

Risk of injury due to movement of the boat.

When an outboard engine is attached to a boat in the water, there is a risk of the watercraft moving unexpectedly. This can result in people on the boat losing their balance and falling, injuring themselves or even going overboard.

Ensure the boat is anchored securely and moves as little as possible.

Attaching to the boat



WARNING

Risk of injury due to heavy weight.

The outboard engine is extremely heavy (at least 175 kg). Only professionals with experience using lifting devices may lift the outboard engine from the transport pallet.

- The outboard engine must only be lifted using a crane or hoist with sufficient lifting capacity.
- Always use appropriate lifting gear for anchoring.
- Only the anchor point under the cowling must be used for lifting the device.



WARNING

Risk of injury due to insufficient fixing.

If the outboard engine is not fixed correctly to the boat, it can become detached from the transom, resulting in very serious injuries or damage.

- The outboard engine must always be fixed securely to the transom using bolts.
- Always use four bolts (**V4A M12**) which pass through the entire transom with washers and nuts for the installation.
- Never use just the bolts in the bracket at the top of the transom for attaching the engine to the boat.

Single engine operation

NOTICE

Insufficient cooling water due to incorrect fixing.

If the anti-cavitation plate is installed too high, the resulting lack of cooling water can lead to overheating of the outboard engine.

Ensure the following installation conditions:

- The outboard engine must be located exactly in the center of the transom.
- The anti-cavitation plate must be located 10 – 30 mm below the hull.
- The anti-cavitation plate must remain under water, even at full speed.

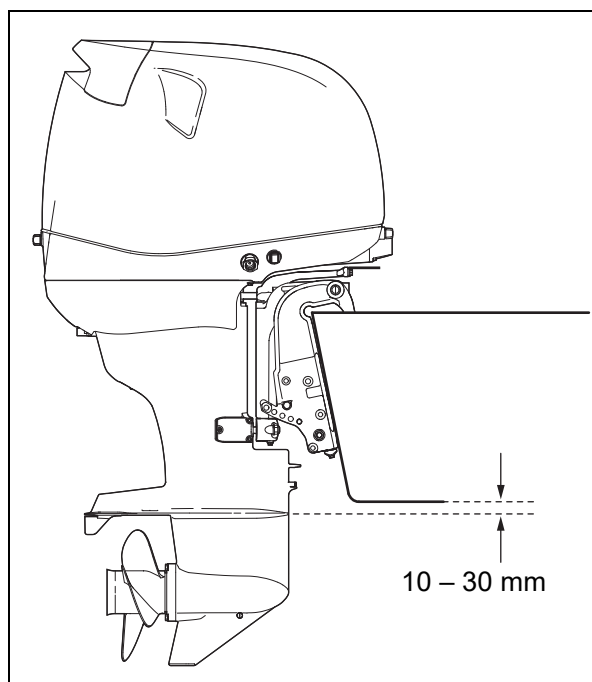

To attach the engine to the boat, you will need 4 **V4A** size **M12** bolts with washers and nuts made of the same material.

In order to protect against fretting corrosion and wear, the entire length of the bolt should be covered with assembly paste for V4A before fixing.

- Mark the middle of the stern on the inside of the transom.
- Mark the location for the 4 holes for the fixing bolts to line up with the holes in the transom (see page 175) at the center of the transom.
- Re-check the height of the bore markings: The anti-cavitation plate must be located 10 – 30 mm below the hull with the outboard engine installed.
- Drill the holes through the transom with a suitable drill.
- If necessary, protect the holes against splash water with a flexible sealant.
- Align the outboard engine directly above the center of the stern and lower it slowly until the transom brackets (2) are seated on the gate (3).
- Orient the outboard engine and, using the two bolts (1) in the brackets, bring it closer to the gate until the transom is seated and the 4 holes in the mount are aligned with the transom.
- Evenly cover the 4 fixing bolts with assembly paste.
- Place a washer on each of the 4 bolts (4) and push the bolts from the inside through the holes in the transom and transom.
- Place washers on the outside and screw on the 4 nuts.
- Tighten the 4 nuts alternately (75 Nm).
- Remove the lifting device.

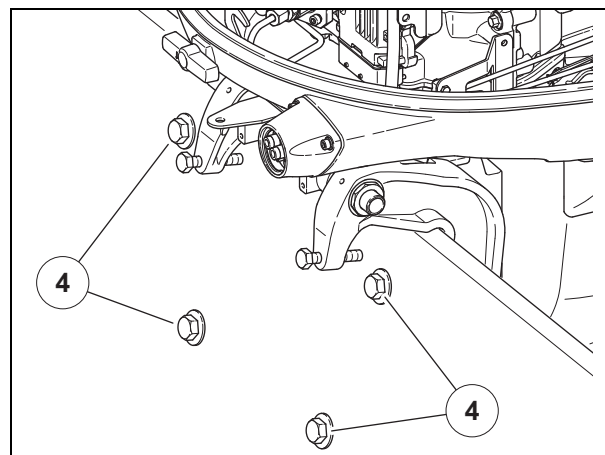
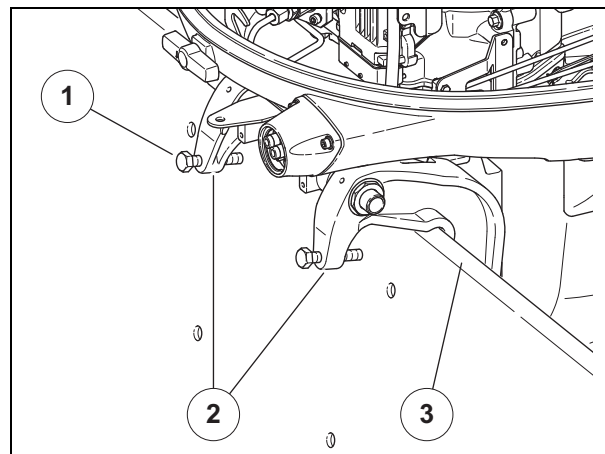
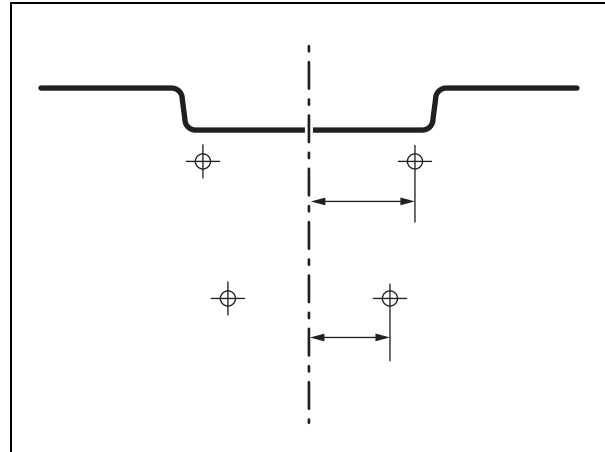

Twin propulsion

When planning twin propulsion, be sure to contact Neander Shark in order to obtain further information first.



CAUTION

Risk of injury due to increased forces when steering.

Operating with twin propulsion increases the steering forces.

Steering with twin propulsion requires the use of a steering linkage and a control box, and is not permitted with a tiller handle.

When operating with twin propulsion, both engines must be the same model and have the same power rating.

The fixing positions will need to be marked out on the boat before attaching the two outboard engines. Measured from the central axis, the distance between the two engines must be 700 – 800 mm.

You will need to attach the linkage (see *Accessories*, page 178) to join the two engines together.

The steps for installing the linkage can be found in the instructions supplied with it.

For more information about the installation and use of the linkage, refer to the information supplied with it. Pay particular attention to all of the safety precautions and information regarding the boat and outboard engine to be united.

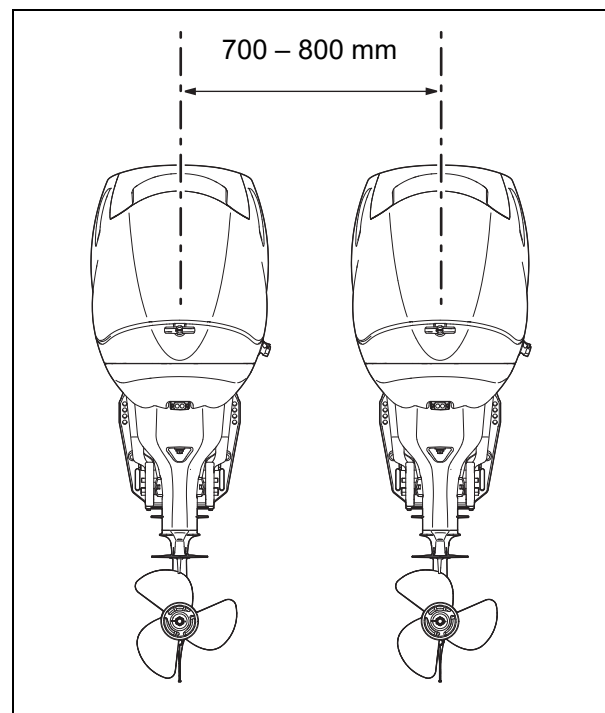

NOTICE

Insufficient cooling water due to incorrect fixing.

If the anti-cavitation plate is installed too high, the resulting lack of cooling water can lead to overheating of the outboard engine.

Ensure the following installation conditions:

- The middle point between the two engines must be located exactly in the center of the stern.
- Both anti-cavitation plates must be located at the same height 10 – 30 mm below the hull (see page 47).
- The anti-cavitation plates on both engines must remain under water, even at full speed.

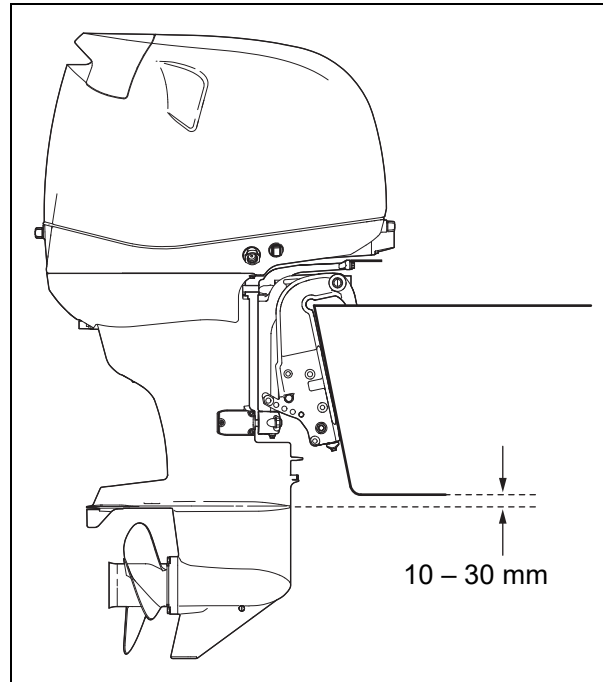

- Mark the middle of the stern on the inside of the transom.
- Mark the location for the 8 holes for the fixing bolts to line up with the holes in the transom (see page 175) at the center of the transom.
- Re-check the height of the bore markings: The anti-cavitation plates must be located 10 – 30 mm below the hull with the outboard engines installed.
- Drill the holes through the transom with a suitable drill.

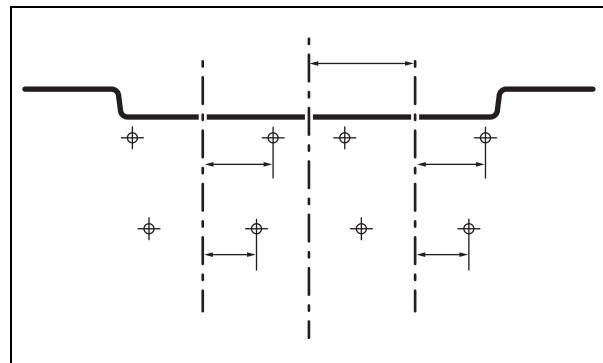

The remaining steps are the same as for single engine operation. Ensure that one outboard engine is fully fixed in place before commencing work on the second.

Removing the transport lock



WARNING

Risk of crushing by transom.

There is a risk of crushing with any movement of the transom.

- Keep fingers away from the transom and the area between the transom and casing.
- When removing the transport lock, ensure the outboard engine cannot swivel or tip.

The transport lock prevents the outboard engine from swiveling in the transom. The transport lock must be installed at all times when the outboard engine is being transported, even when it is fixed to the boat if there is no steering linkage.

The transport lock must be removed when operating the outboard engine.

After removing the transport lock, store it in a safe place (such as the boat toolbox) for future use.

- Unscrew the two transom bolts (1) on the front, underneath the cowl.
- Unscrew the bolts (3) of the mount for the steering linkage and remove the two plates of the transport lock (2).
- If no tiller handle is going to be installed, reattach and tighten the bolts (3) with the washers.
- Store the unused bolts and transport lock for future use.

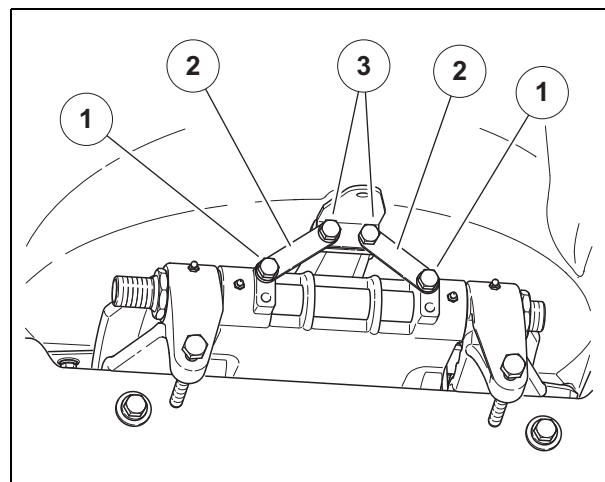

Installing the control box and steering linkage



WARNING

Risk of injury due to unexpected movement when starting up the engine.

If the control box shift and throttle lever is in the forward or reverse position when starting up the engine, the boat may make unexpected movements. This can result in people on the boat losing their balance and falling, injuring themselves or even going overboard.

Only connect the outboard engine to a control box that prevents the engine from being started up if the shift and throttle lever is not in the neutral position.

The outboard engine can be controlled remotely using a control box and steering linkage. The following is a description of the installation of the control box available from Neander Shark.

The installation of the steering linkage depends on the model and is not described in this owner's manual.

For more information on installing and handling the steering linkage, refer to the documentation supplied with it. Pay particular attention to all safety precautions and information regarding the engine to be controlled by the steering linkage.

The mount (1) for the steering linkage is located on the front of the outboard engine, underneath the cowling.

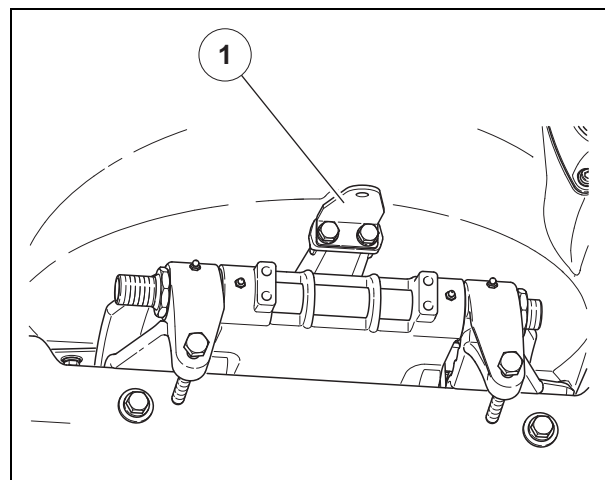

Connecting the control cables

NOTICE

Possible damage to control cables and leads.

Excessive bends in the control cables will result in increased wear, sluggishness and possible damage to the cables.

Kinks or pinches in the leads can lead to severe damage or loss of functionality.

Ensure that all control cables and leads are routed avoiding tight bends. They must not have any kinks or pinches under any circumstances.

Before mounting the control box to the boat, be sure to connect the control cables from the throttle lever and shift lever of the outboard engine to the inside of the control box.

Check for suitable control box installation locations on the boat based on the length of the control cables and electrical leads.

Keep the control cable bending radius to no less than 210 mm to prevent damage to or sluggishness in the mechanical system.

If necessary, the shift and throttle lever can be reconfigured to the other side of the control box (see page 56).

- Completely unscrew the two bolts (1) on the back of the control box and remove the cover (2).

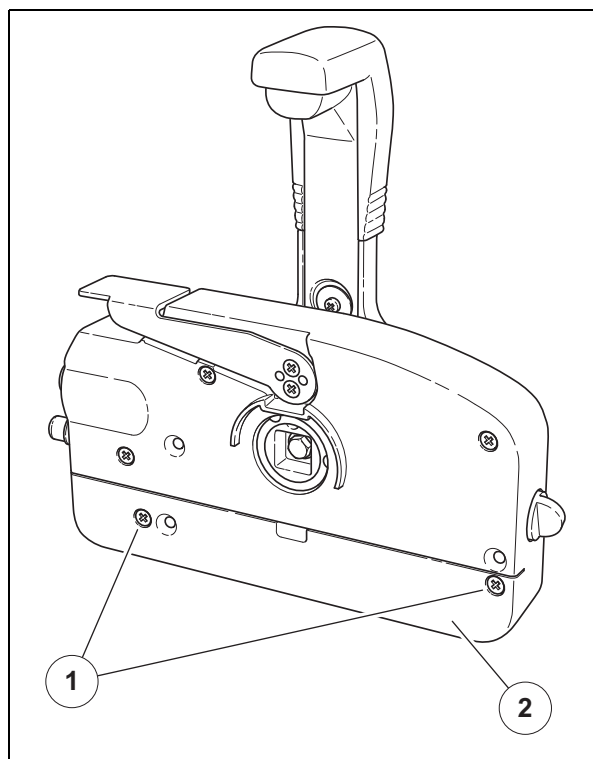

- Screw a nut (1) and a knuckle eye (2) onto the end of each control cable.
- Tighten the nut against each knuckle eye to secure the connection.
- Grease both knuckle eyes.

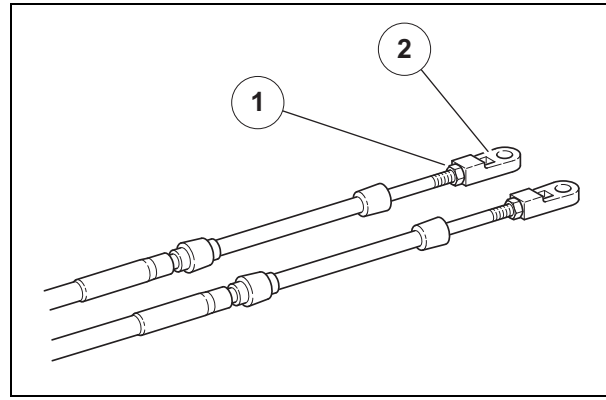

- Insert the control cable from the shift lever of the outboard engine into the opening (3) at the rear of the control box.
- Insert the knuckle eye onto the pin (5) of the shift arm and secure it with a circlip.
- Install the rubber seal (4) above the control cable in the opening.

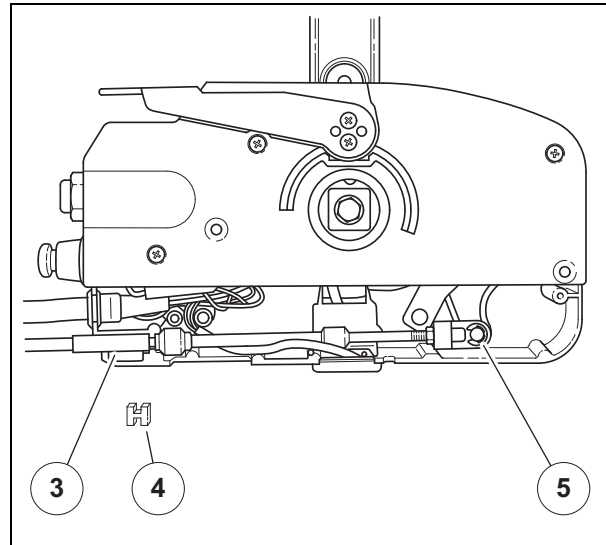

- Insert the control cable from the throttle lever of the outboard engine into the opening (3) and the rubber seal at the rear of the control box.
- Insert the knuckle eye onto the pin (6) of the throttle arm and secure it with a circlip.
- Install the cover and fasten it with the two bolts.

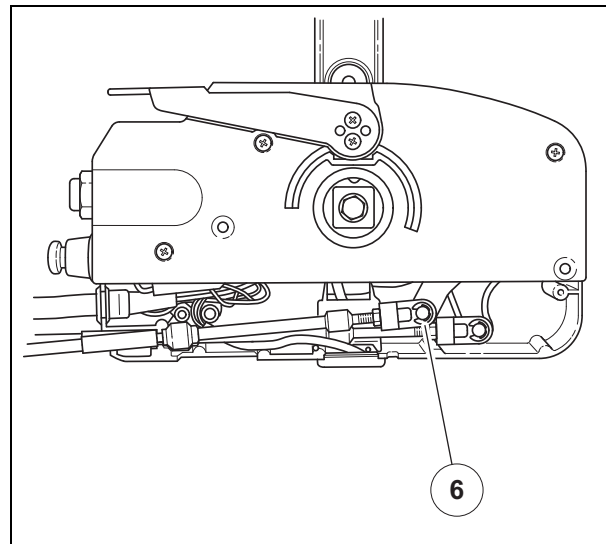

Installing the control box

Before mounting the control box to the boat, the control cables from the throttle lever and shift lever of the outboard engine must have been connected to the inside of the control box (see page 53).

The control box is mounted to the boat with 3 bolts.

- Mark the 3 hole positions on the boat through the holes (1) in the control box and drill the holes with a suitable drill.

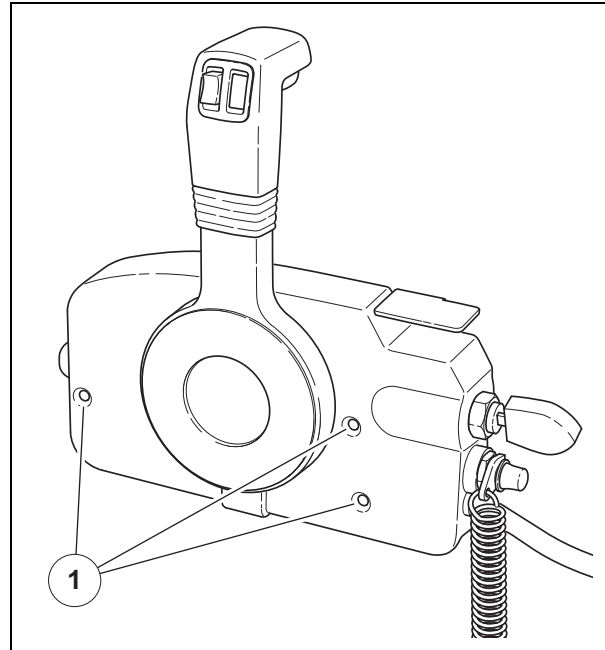

- Insert the bolts (2) through the holes in the control box and place one spacer (3) on each at the rear.
- Align the control box with screws and spacers onto the holes in the boat and insert the screws into the holes.
- Place and tighten one nut (5) with one washer (4) on each of the 3 screws.
- Make sure that the control box is firmly seated and that the shift and throttle lever can be moved.

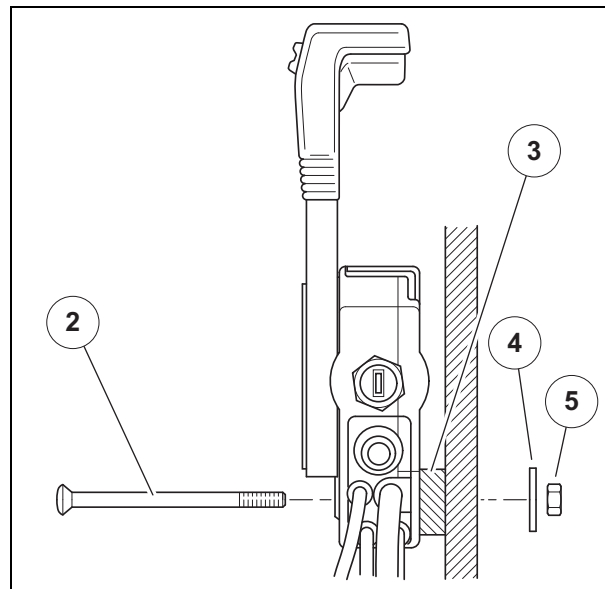

Reconfiguring the shift and throttle lever

If necessary, the shift and throttle lever can be reconfigured to the other side of the control box.

- Completely unscrew the two bolts (1) on the back of the control box and remove the cover (3).
- Using a socket wrench, loosen the fixing bolt (2) of the shift and throttle lever and completely remove it and its washer.
- Remove the shift and throttle lever.

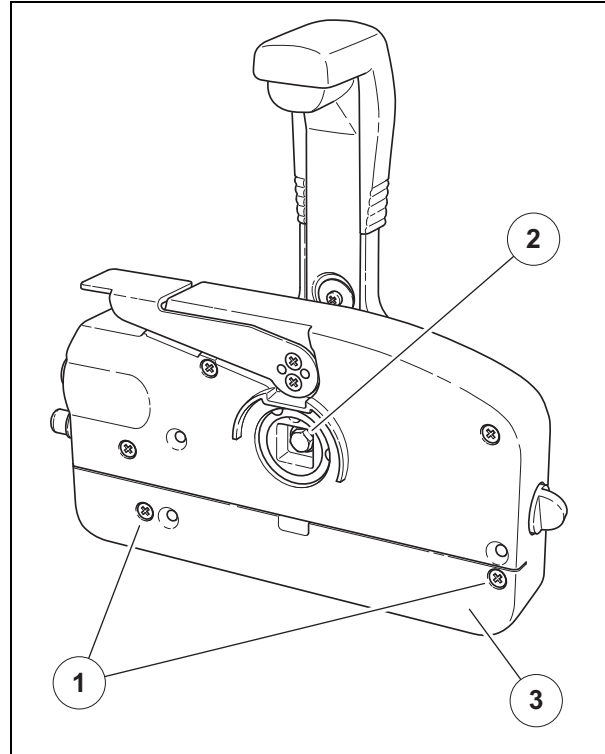

- Remove the cable cover (6) at the bottom of the control box.
- Place the electrical lead (5) on the other side of the control box and reinstall the cable cover (4).
- Place the electrical lead in the notch in the cover (4).
- Install the cover and fasten it with the two bolts.

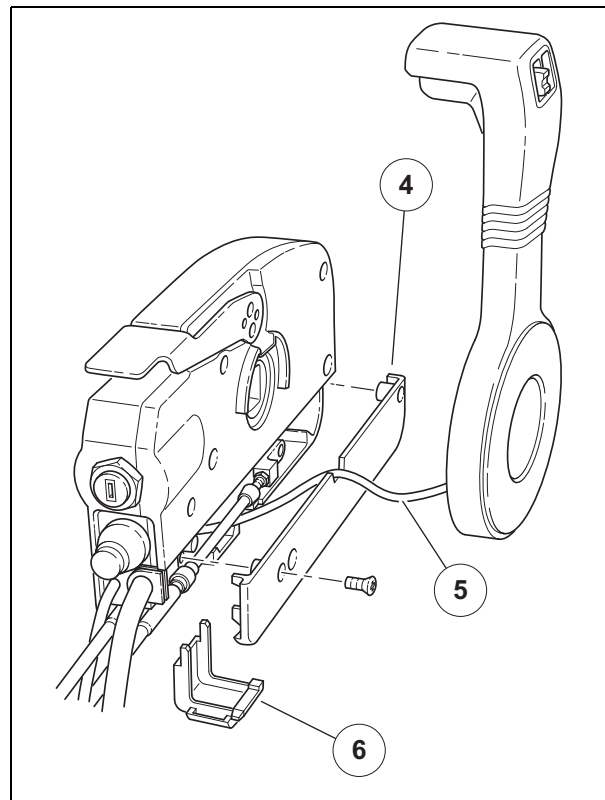

- Guide the electrical lead inside the hub (3) of the control and throttle lever.
- Carefully align the shift and throttle lever onto its pivot hole, making sure not to squeeze in the electrical lead.
- Install the fixing bolt (1) and washer (2) and tighten the bolt.

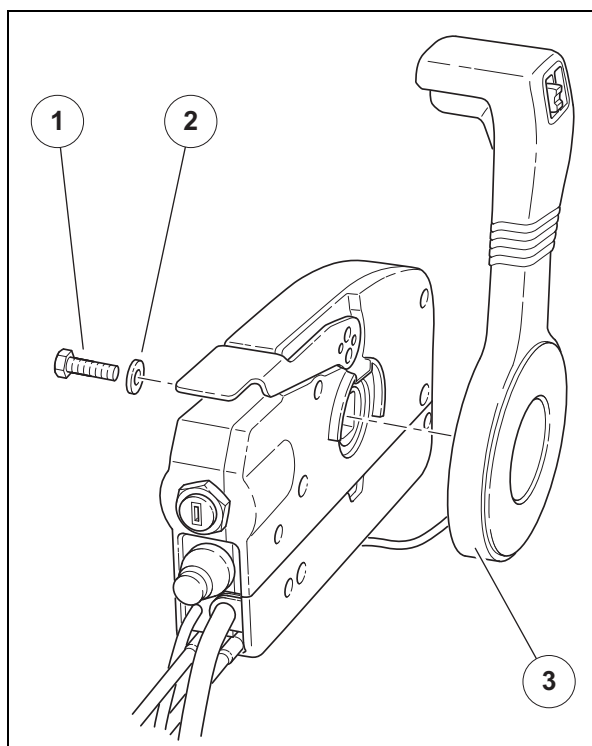

Installing the tiller handle

A dedicated tiller handle (optional) can be attached to the outboard engine for operation and control.

A control box and steering linkage must be used when operating the boat with twin propulsion; a tiller handle may not be used.

Only the optional tiller handle recommended by Neander Shark must be used. Attaching any other tiller handle to the engine is not permitted.

The tiller handle already comes equipped with cables and leads.

- Unscrew the two bolts (2) from the mount for the steering linkage and remove the mount (1).
- Screw in the two stud bolts.

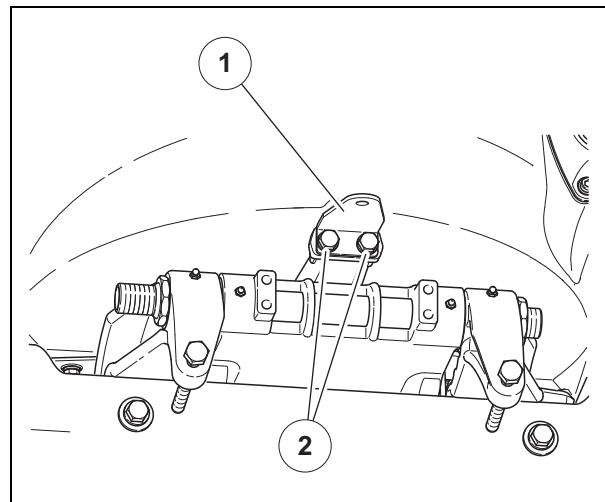

- Align and slide the tiller handle onto the stud bolts.
- Screw the two nuts (3) with washers onto the stud bolts.
- Tighten both nuts (26 Nm) and check the tiller handle is fixed securely in position.

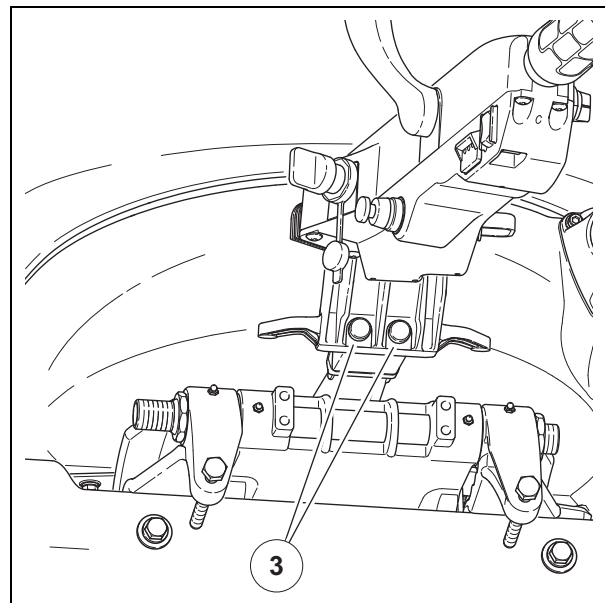

Installing the mechanism for the steering resistance

When using a tiller handle with the outboard engine, it is possible to install a mechanism for providing steering resistance to the tiller.

The steering resistance is only intended to help you maintain the tiller handle in the desired steering position.

The steering resistance is not intended for the boat to be steered without tiller handle operation.

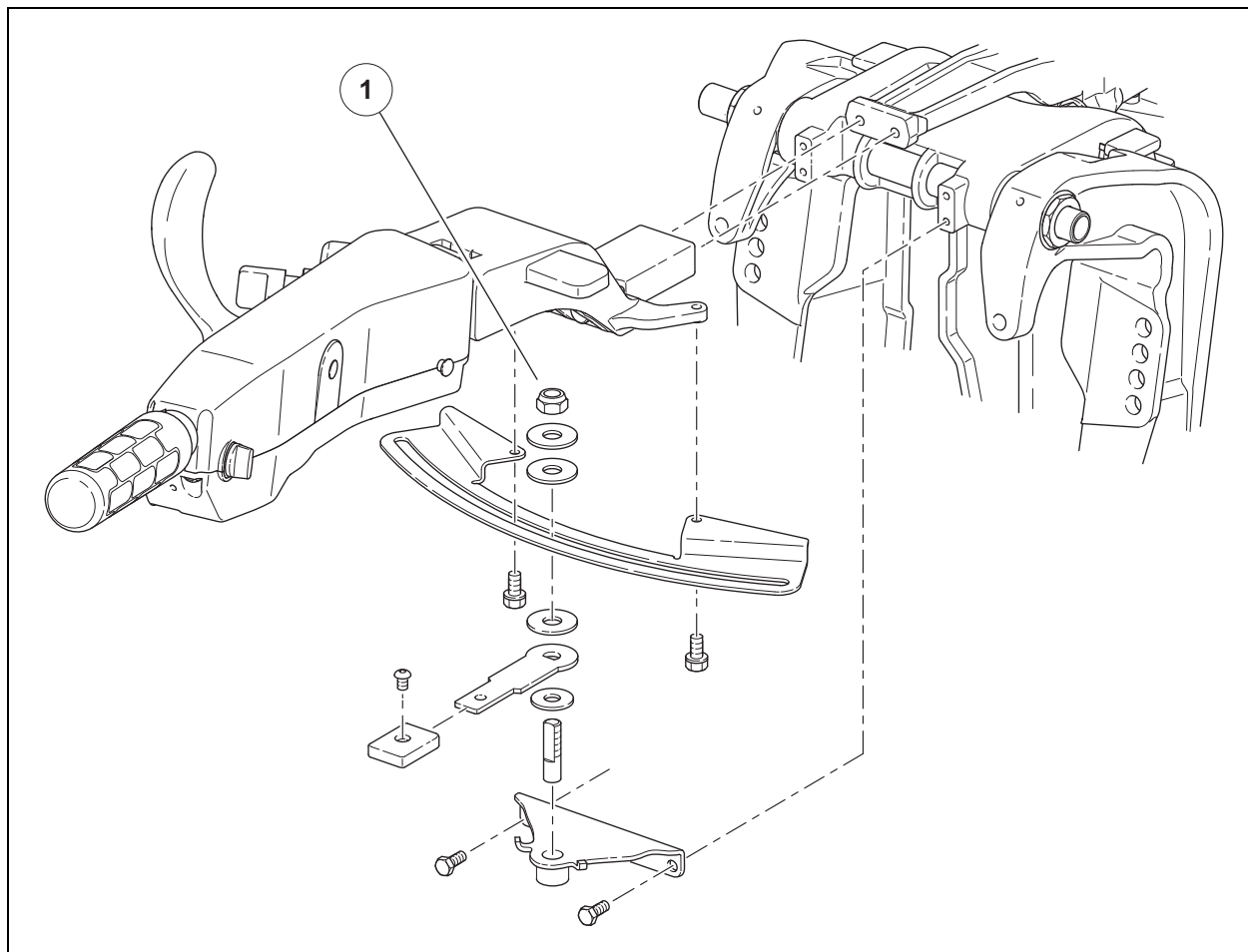

- Assemble and install the steering linkage mechanism as shown in the drawing.
- Only tighten the nut (1) slightly at first so that the tiller handle can be moved freely.
- Once all of the connections have been made, adjust the steering resistance (see page 72).

Battery



WARNING

Explosion hazard and risk of injury due to incorrect handling of battery.

Batteries can produce explosive hydrogen gas. In certain situations (e.g., during charging), there can be a danger of explosion.

Batteries can contain highly poisonous or corrosive materials. Contact with these substances can result in serious burns or poisoning.

Follow all of the warnings on the battery and all of the safety precautions provided in the instructions supplied with the battery.

Selecting a battery

When selecting a battery, take into account the minimal capacity requirements (see *Technical data* from page 171 onwards).

Ensure you always check with the manufacturer of the battery or in the documentation supplied with the battery whether it is suitable and approved for use with the outboard engine.

Installing the battery

The instructions for installing the battery can be found in the owner's manual for the boat.

Find out how to install the battery correctly in the owner's manual of your boat. Pay particular attention to any safety precautions and instructions related to the engine that will be connected to the battery.

If you cannot find this information or are still unsure, contact a specialized workshop for installing the battery safely and correctly.

Fuel tank



WARNING

Danger of fire due to fuel.

Diesel fuel spills or leaks can be ignited on very hot surfaces or next to open flames, which can result in serious burns.

Before transporting the fuel tank, ensure that all openings are closed and that no fuel can leak out.

Installing the fuel tank

Find out how to install the fuel tank correctly in the owner's manual of your boat. Pay particular attention to any safety precautions and instructions related to the engine that will be connected to the fuel tank.

Only marine fuel tanks suitable for supplying diesel fuel (in accordance with EN 590) with a suction port, return port and ventilation device are permitted.

If you do not have all of the information required for installation or are unsure, contact a specialized workshop for installing the fuel tank safely and correctly.

Installing the fuel filter

NOTICE

Possible damage to the fuel system and engine.

Only operate the engine with a fuel filter with water separator installed in the fuel feed line between the fuel tank and the connection to the engine.

The fuel filter must have a 30 µm filter element, a water separator and a hand primer. We recommend the following model of fuel filter:

Parker | Racor 215RM30MTC

Information on how to install the fuel filter correctly can be found in the documentation provided with the filter.

Pay particular attention to all safety precautions and instructions with regard to the correct installation position and use of the fuel filter.

If you do not have all of the information required for installation or are unsure, contact a specialized workshop to install the fuel filter safely and correctly.

Connections to the engine

NOTICE

Possible damage to control cables and leads.

Excessive bends in the control cables will result in increased wear, sluggishness and possible damage to the cables.

Kinks or pinches in the leads can lead to severe damage or loss of functionality.

Ensure that all control cables and leads are routed avoiding tight bends. They must not have any kinks or pinches under any circumstances.

Preparing the duct

All control cables and leads from the control box or from the tiller handle must pass through the sealed duct (1) in the lower cowling to the engine.

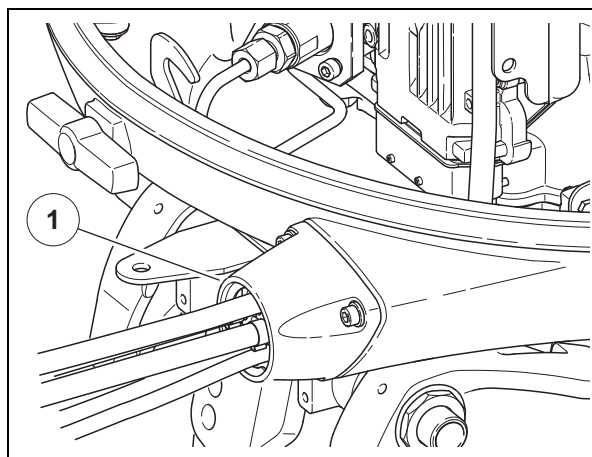

- Remove the 3 screws in the duct cap (2) and store them in a clean place together with the washers.
- Remove the cap from the duct.
- Remove the rubber seal (3) from the cap.
- Next, pass all of the control cables and leads through the cap (2) and the duct (1), and then connect them.

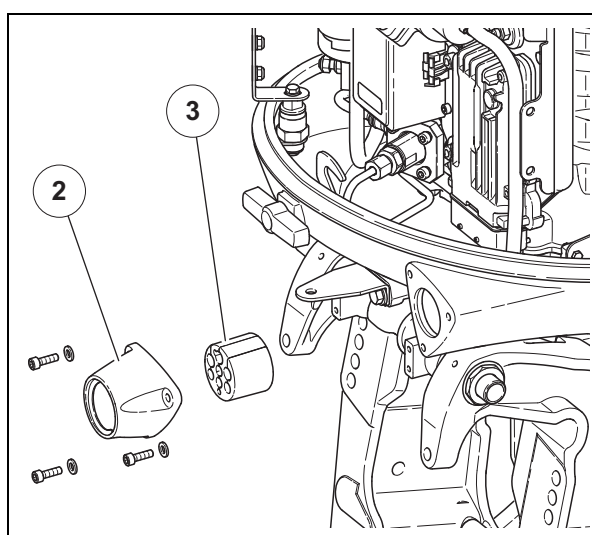

Connecting the control cables

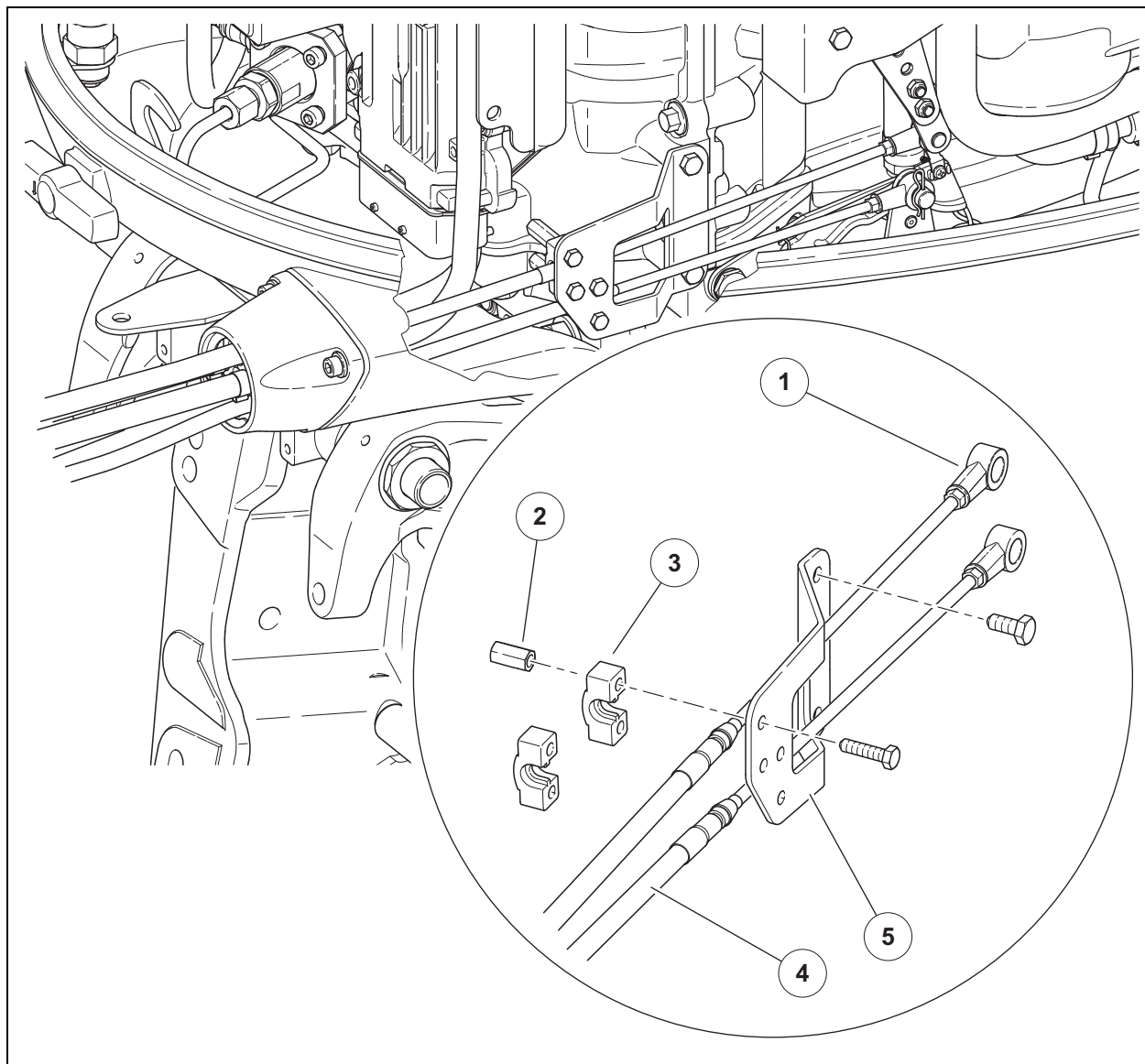

- Pass both control cables through the duct cap.
- Screw the knuckle eyes (1) onto the thread on the control cables.
- On the inner side of the retaining plate (5), unscrew the 4 long nuts (2) and completely remove the 4 bolts.
- First of all, pass the control cable (4) from the shift lever through the retaining plate.
- From the inner side, place the clamp (3) across the groove in the control cable sleeve and fix it onto the retaining plate with the two screws and the long nuts.

- Remove the lock pin (2) from the pin (3) of the lower lever, push the knuckle eye of the control cable (1) from the lever shift onto the pin from the front, and then reinstall the lock pin.
- Ensure that the control cable is fixed securely onto the lever.

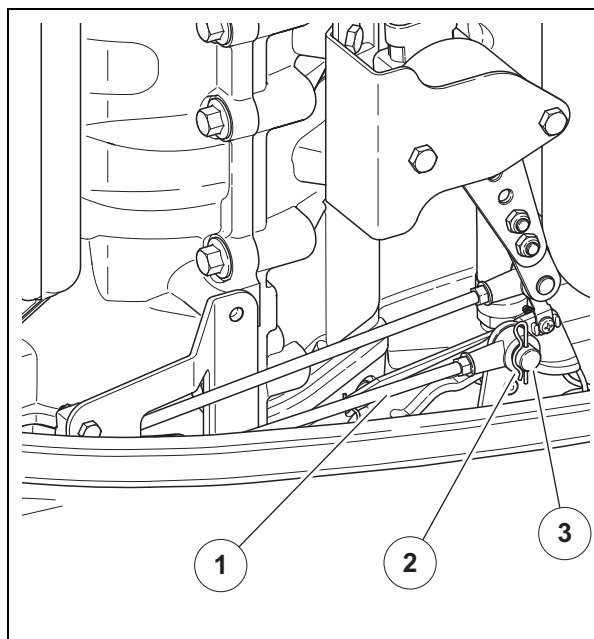

- Pass the control cable from the throttle grip through the retaining plate.
- From the inner side, place the clamp across the groove in the control cable sleeve and fix it at the top of the retaining plate with the two screws and the long nuts (see page 63).
- Remove the lock pin from the pin (5) of the upper lever, push the knuckle eye of the control cable (4) from the throttle grip onto the pin from behind, and then reinstall the lock pin.
- Ensure that the control cable is fixed securely onto the lever.

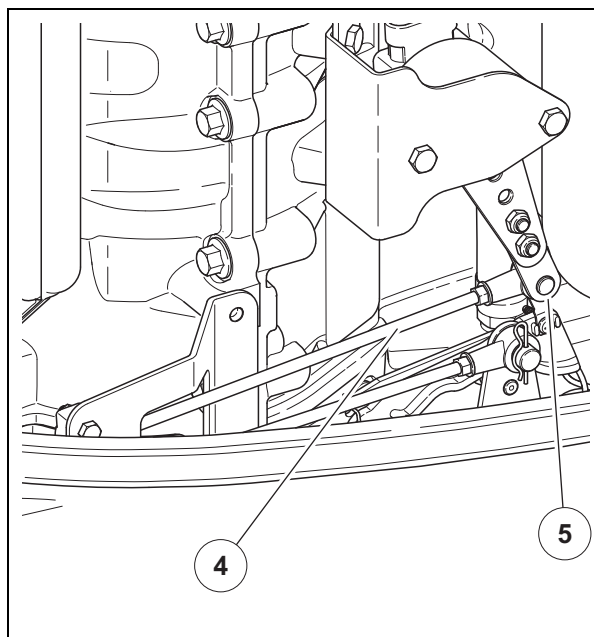

Connecting the leads

The leads from the control box or from the tiller handle need to be joined to the leads on the engine. Each lead has a plug which will only fit into the correct socket for the connection to the engine.

Do not use excessive force when connecting a plug to its socket. Check first of all whether the plug and the socket are compatible and that the plug is aligned correctly with the socket.

You will need to make the following electrical connections:

- separate power supply for ECU (1)
- Water in fuel alarm (2)
- Speedometer or diagnostic tool (3)
- Tiller handle or control box (4)

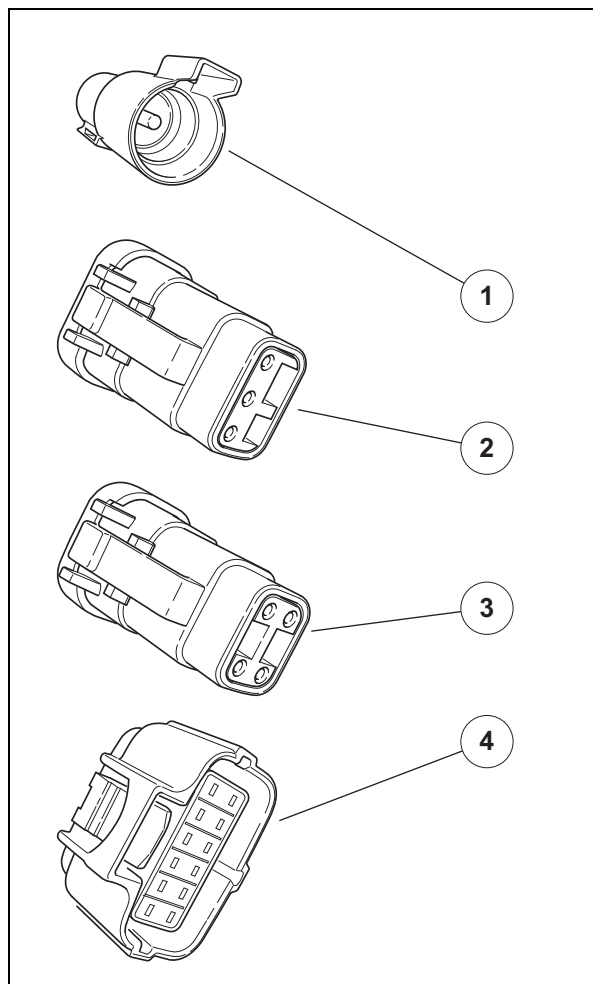

- Pass the leads through the duct cap.
- Push each plug into the corresponding socket in the engine compartment until it locks into place.
- Check that all of the connections are secure.

Connecting the battery



CAUTION

Risk of injury due to incorrect connection of the battery.

Incorrectly routed battery leads can be crushed and damaged as a result of movement by the outboard engine. This can result in failure of the power supply to the engine, which could make it impossible to maneuver the boat.

Ensure that the battery leads cannot be damaged, crushed or pinched.

NOTICE

Possible damage to the electric system.

Incorrect connections can damage the electrical components of the outboard engine.

- Ensure that the battery poles are correctly assigned.
- Do not disconnect the battery when the outboard engine is being operated.

Before connecting the battery, ensure that it is fully charged. Only ever connect a fully charged battery.

Connect the 3 battery leads first to the motor, then to the battery.

Connect the positive lead together with the supplementary lead for the ECU power supply (see page 65) to the positive battery pole first in order to avoid a short circuit between the wrench and metallic parts of the boat.

- Pass the 3 battery leads in sequence (not together) through the duct cap.
- Completely unscrew the nut (2) from the stud bolt on the starter motor switch.
- Place the eyelet on the lead from the positive battery pole onto the screw and install the nut.
- Ensure that the connection is tight.
- If equipped, place the protective cap over the stud bolt.
- Completely unscrew the nut (1) from the stud bolt on the starter motor.
- Place the eyelet on the lead from the negative battery pole onto the screw and install the nut.
- Ensure that the connection is tight.

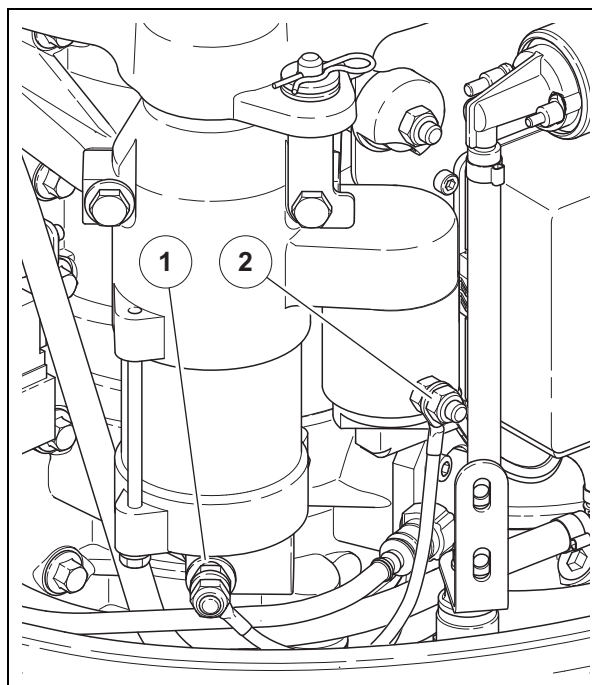

Connecting the fuel lines

2 fuel lines will need to be connected to the engine. Both fuel lines must be secured using a hose clamp.

- Route the two fuel lines avoiding kinks and tight bends.
- Pass the fuel lines through the duct cap.
- Push the fuel line for the return flow into the tank, with a hose clamp, onto the straight tee piece (3) under the fuse box.
- Tighten the hose clamp and ensure that the connection is tight.
- Push the fuel line for the feed from the tank, with a hose clamp, onto the connecting piece (4) at the top of the electric fuel pump.
- Tighten the hose clamp and ensure that the connection is tight.

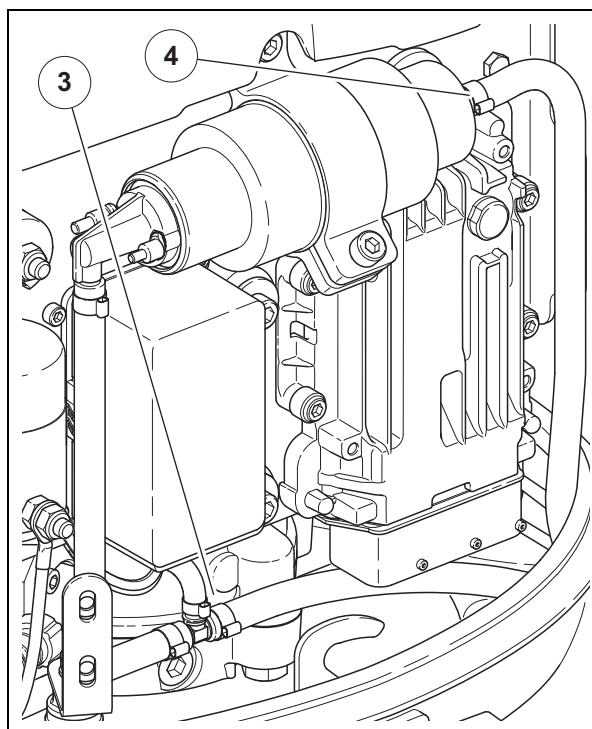

Closing the duct

Once all of the control cables and the leads from the control box or from the tiller handle have been connected, seal off the duct with the rubber seal and cover it with the cap.

- 1 Supplementary battery lead
- 2 Main lead to tiller handle or control box
- 3 Throttle control cable
- 4 Fuel feed line
- 5 Shift control cable
- 6 Lead for water in fuel alarm
- 7 Negative battery lead
- 8 Instrument lead (tachometer)
- 9 Positive battery lead
- 10 Fuel return line

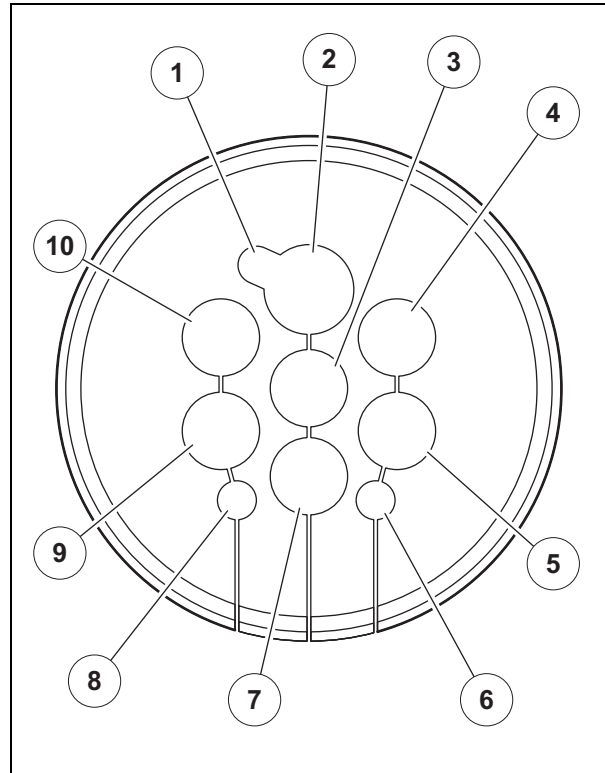

- Slightly bend open the rubber seal and, one by one, place all of the control cables and electrical leads into the seal from the top to the bottom.
- Push the cap (11) onto the rubber seal (12), and then place it on the duct (13).
- Install and tighten the 3 bolts with washers.
- Ensure a secure and tight fit.

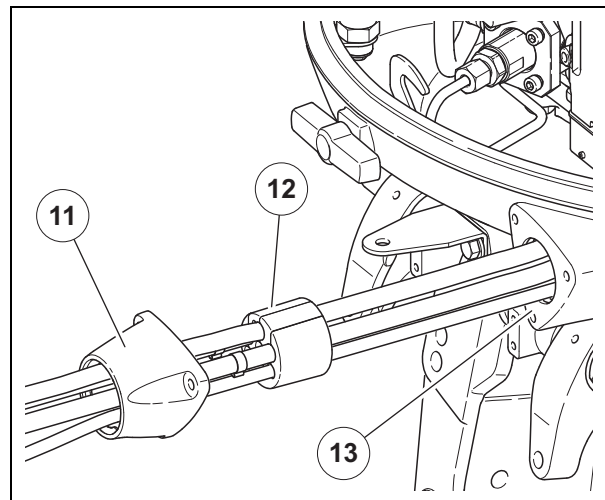

Settings

Adjusting the control cables

You will need to adjust the control cables so that the movements can be transferred correctly to the levers on the engine.

- Turn the throttle grip on the tiller handle clockwise as far as it will go (idling speed).
- Put the shift lever in the neutral position (**N**).

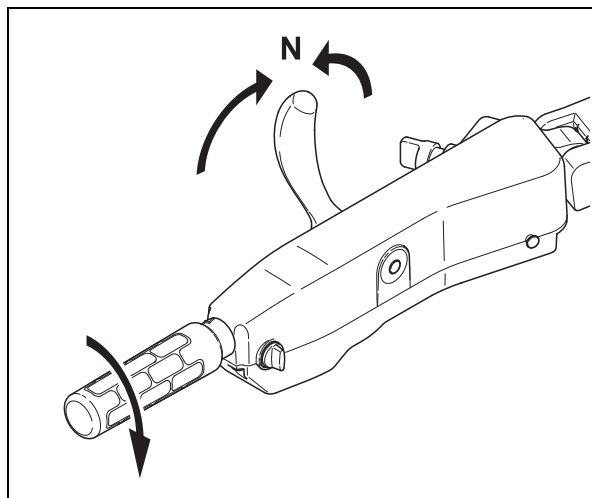

- Put the shift and throttle lever on the control box into the neutral position (**N**).
- Completely close the throttle lever for warm-up (1).

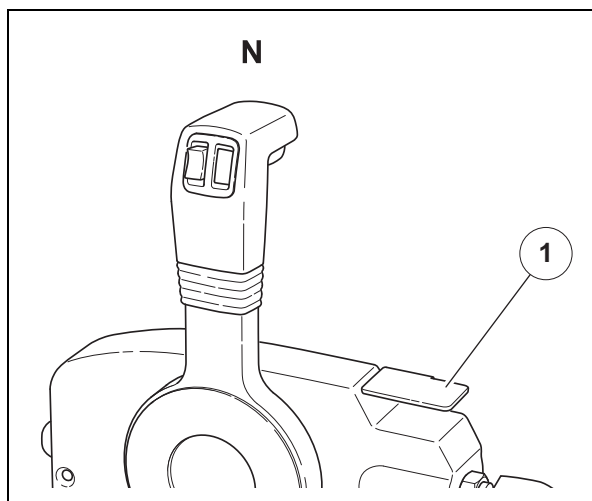

- Remove the lock pin (1) from the pin (2) of the lower lever on the engine, and then remove the knuckle eye connected to the control cable.
- Place the shift lever on the engine in the middle position (neutral position).

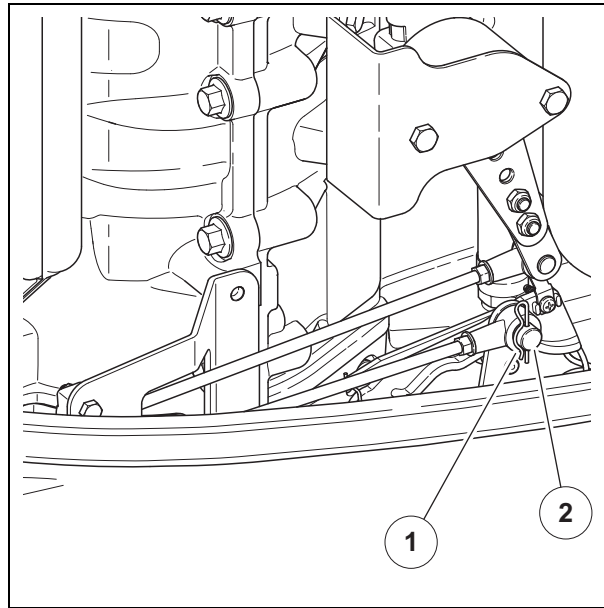

- Loosen the lock nut (3) on the knuckle eye and tighten the knuckle eye onto the thread on the control cable so that it is flush with the pin (4) and can be moved slightly without moving the lever.
- Place the knuckle eye onto the pin and reinstall the lock pin.
- Move the shift lever on the tiller handle or the shift and throttle lever on the control box back and forth to check that the movement is transferred correctly to the lever on the engine.
- Tighten the lock nut, and then make sure that the control cable is securely connected to the lever.

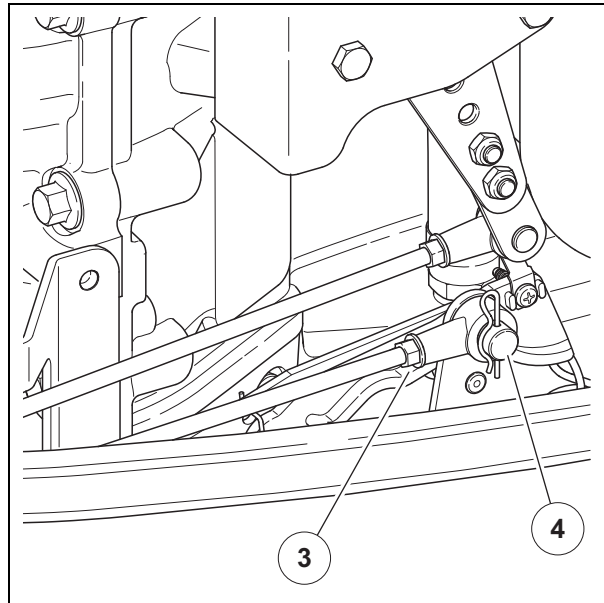

- Remove the lock pin from the pin (2) of the upper lever on the engine, and then remove the knuckle eye of the control cable from the pin.
- Move the throttle lever on the engine to the back position (minimum throttle position).
- Loosen the lock nut (1) on the knuckle eye and tighten the knuckle eye onto the thread on the control cable so that it is flush with the pin and can be moved slightly without moving the throttle lever.
- Place the knuckle eye onto the pin and reinstall the lock pin.
- Move the throttle grip on the tiller handle or the shift and throttle lever on the control box between the two end positions in order to check that the movement is transferred correctly to the throttle lever on the engine.
- Tighten the lock nut, and then make sure that the control cable is securely connected to the throttle lever.

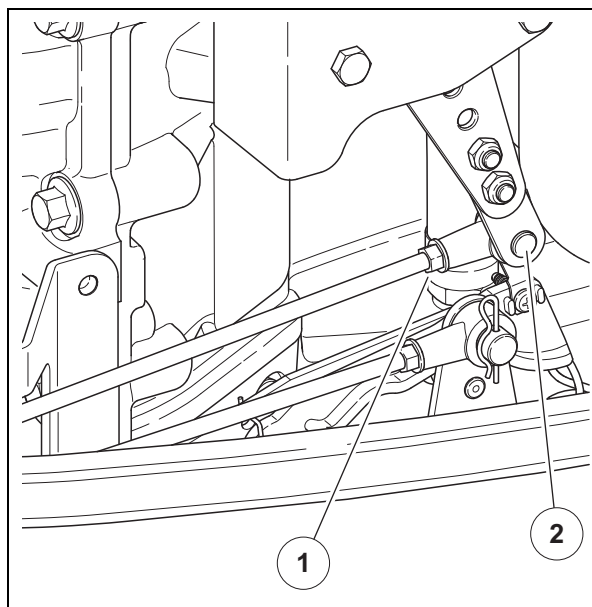

Adjusting the control resistance



WARNING

Danger due to fast moving engine.

If the resistance is adjusted too high, the throttle grip will remain in the selected position even when released. This can result in loss of control of the boat and thereby to serious injuries.

If necessary, you can adjust the resistance of the throttle grip. Increasing the resistance makes it more difficult to turn the throttle grip but also means that the grip will stay in the selected position when released.

- Turn the adjusting screw (1).
- Turn the throttle grip and check the resistance setting.

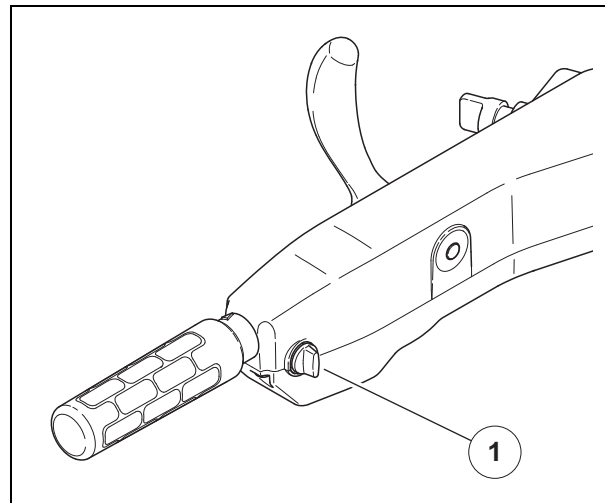

Adjusting the steering resistance

Using the nut (2), set the maximum retention force for the steering resistance. It is important that the tiller handle can still be moved to ensure that the boat can be steered in all situations.

- Set the lever (3) all the way to starboard, which is the holding position.
- Tighten the nut (2). The tiller handle should now stay in the same position but can still be moved.
- Move the lever (3) all the way to port. The tiller handle should now move without any resistance.
- If the tiller handle stays too firmly in the holding position, you may need to loosen the nut slightly.

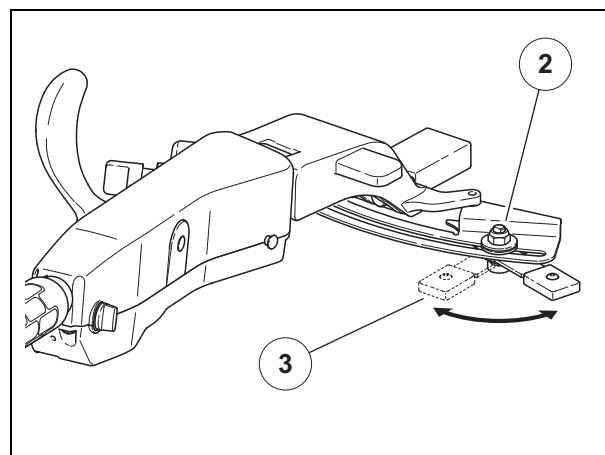

Adjusting the trab trim

There is a trab trim located underneath the anti-cavitation plate. You can set the angle of the trab trim so that it balances out the asymmetric thrust on the boat (propeller walk), reducing possible steering resistance when traveling in a straight line.

Especially in the case of twin propulsion, you might notice that the boat has a tendency to veer to one side when traveling in a straight line. You can balance out this effect by setting the trab trims on both outboard engines. If the boat pulls to the right, you will also need to orient the trab trim to the right as the trab trim does not steer the boat but the outboard engine. The ideal position can be determined by carrying out several test runs.

- Remove the hexagon socket screw (1) on the upper side of the anti-cavitation plate.
- Rotate the trab trim (2) by hand to set the angle.

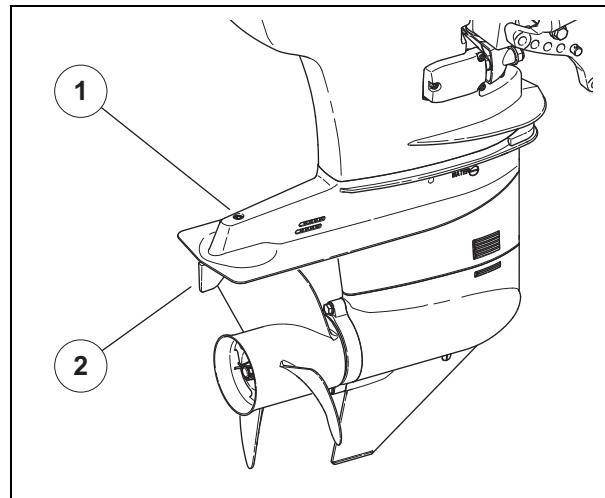

- For future reference, read and note the position on the scale (3) on the underside of the trab trim.
- Tighten the hexagon socket screw (1).

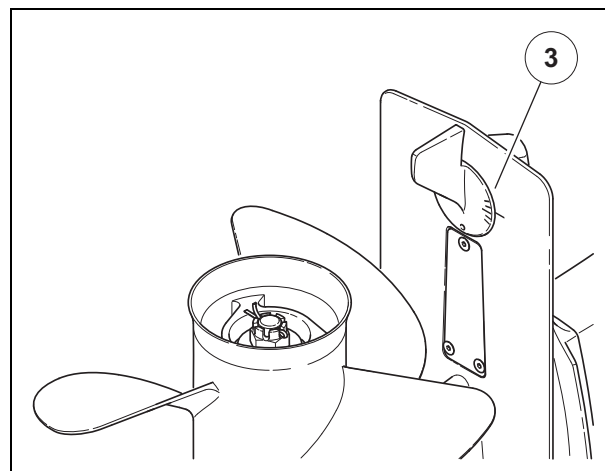

– Blank page –



Operation

Safe operation



DANGER

Life-threatening danger due to rotating propeller.

The propeller blades have very sharp edges. There is a very high danger of serious cuts from the propeller, which can even result in death.

There is even a risk of injury when the propeller is not rotating.

Observe the following basic safety instructions at all times.

Start-up

- Never start the engine when passengers are boarding or alighting from the boat.
- Do not start up the engine if the propeller is not in the water.
- The engine should only be started up with the cowl closed and locked.
- When boarding the boat, never use the out-board engine as a support and do not step on the anti-cavitation plate, propeller, housing or other components.
- Before starting up the engine, ensure that it is fixed securely to the boat.
- Before starting up the engine, ensure that the tank connections are secure and there is no sign of leakage.
- Before starting up the engine, ensure that the shift lever is in the neutral position.
- Before starting up the engine, attach the kill switch lanyard to your body.
- Make sure that the second kill switch lanyard is within easy reach.

Travel

- Never leave the boat with the outboard engine running.
- The outboard engine must never be left without supervision.
- Observe the area around the boat at all times and be prepared to stop the outboard engine at any moment.
- Maintain a safe distance from people and objects in the water, even when the engine is idling. Observe a minimum safety distance of at least 30 m to swimmers and divers.
- Never reverse towards a person or an object in the water.
- Never tilt the outboard engine out of the water when it is running.
- Never open the cowling when the outboard engine is running.

Stopping

- Do not leave the boat until the outboard engine is completely stopped and the propeller is no longer turning.
- Safeguard the outboard engine from unauthorized or unintentional start-up, by removing the ignition key, for example.
- When alighting from the boat, never use the outboard engine as a support and do not step on the anti-cavitation plate, propeller, housing or other components.

Environmental protection

Before starting your ride, make sure you find out about local regulations regarding environmental and water protection. Observe the following:

- Avoid polluting water from leaking liquids such as engine oil or fuel.
- Before start-up, ensure that the tank connections are secure and there is no sign of leakage.
- During operation, check for signs of oil or fuel leaking into the water. If there is a leak, stop your ride and fix the leak before continuing.

Breaking-in instructions

NOTICE

Reduced engine performance if you do not observe the breaking-in instructions.

Not observing the breaking-in instructions can reduce the useful life and the performance of your outboard engine.

Operation during the breaking-in phase

If you observe any unusual noises or unexpected reactions from the outboard engine during the breaking-in phase,

- immediately stop operation and
- have the outboard engine inspected by your dealer or a specialized workshop.

Follow these running-in instructions during the first 10 hours of operation:

- Maximum engine speed during the first 3 hours = $2,000 \text{ min}^{-1}$
- Maximum engine speed during the next 3 hours = $2,500 \text{ min}^{-1}$
- Maximum engine speed during the next 3 hours = $3,000 \text{ min}^{-1}$
- Maximum engine speed during the next 1 hour = $3,500 \text{ min}^{-1}$

After those 10 operating hours, the running-in phase is completed and the outboard engine is ready for normal operation under full load.

Shortened maintenance intervals

Some one-time maintenance tasks will need to be carried out in addition to the normal maintenance interval tasks after the first **50 operating hours** (see page 122).

Cold start

Follow these warm-up instructions when first starting up the cold outboard engine:

- Maximum engine speed during the first 5 minutes = $1,600 \text{ min}^{-1}$
- Over the next 10 minutes, gradually increase the speed to the desired speed.

When the outboard engine is warm:

- Maximum engine speed may be reached 10 seconds after start-up. It takes 10 seconds for the required oil pressure to reach all areas of the engine.

Special operating conditions

Operating at low temperatures

Fuel



WARNING

Danger of reduced maneuverability due to incorrect fuel.

The outboard engine must be capable of starting up at low temperatures, otherwise there is a danger of reduced maneuverability of the boat.

At low atmospheric temperatures (under 0 °C), winter diesel must be used. Observe the supplier or vendor specifications.

Cooling water

NOTICE

Risk of damage due to freezing cooling water.

At extremely low temperatures, the residual water in the cooling circuit can freeze if the outboard engine is not used for a prolonged period of time. This can result in damage to the water pump.

Make sure that no residual water remains in the cooling circuit.

Ensure you wait one minute for the water to run out of the cooling ducts before tilting up the outboard engine. Water freezing in the cooling ducts can result in destruction of the components.

Tilt the outboard engine up until it is completely out of the water.

After starting the outboard engine, always allow it to warm up before switching it off again. The cooling circuit is sufficiently heated to allow residual water to drain before the next freeze only once it has reached operating temperature.

Store the boat with the outboard engine mounted in a frost-proof place.

Battery

With temperatures below $-5\text{ }^{\circ}\text{C}$, it is recommended to connect a second battery of the same capacity in parallel to the first battery.

Operation in salt water

NOTICE

Danger of damage caused by corrosion.

Salt water, brackish water or water polluted with chemicals can lead to damage by corrosion, especially in the cooling circuit.

Flush out the cooling circuit with fresh water after each operation.

If the outboard engine is used in salt water, brackish water or water polluted with chemicals, it must be cleaned thoroughly with fresh water after each operation.

The cooling circuit must always be flushed thoroughly (see page 124).

Handling the cowling

Removing the cowling

In order to carry out certain tasks, you will need to remove the upper cowling.

- Stop the outboard engine, switch it off and ensure it cannot restart, by removing the ignition key, for example.
- Turn the lock knobs (1) on the front and back counterclockwise as far as they will go in order to open the hood.
- Remove the cowling vertically upwards and carefully place it away from the working area and any traffic routes.

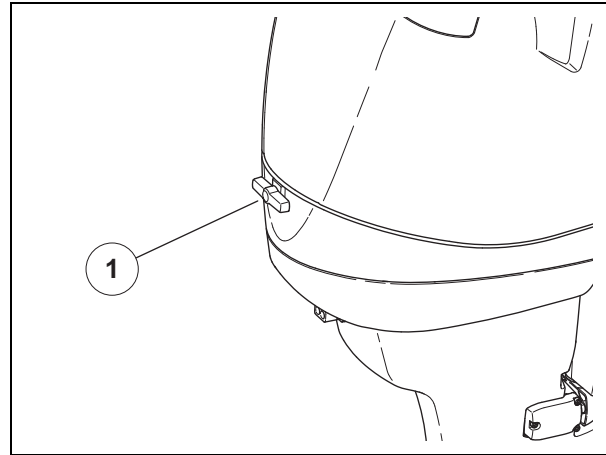

Installing the cowling

NOTICE

Danger of damage.

Loose parts under the cowling can lead to serious damage during operation.

Before installing the cowling, ensure that there are no tools or loose parts in the area around the engine and in the lower cowling.

- Check that the seal (2) is evenly seated all along the lower cowling and that no leads or lines can be crushed when installing the cowling.
- Slowly lower the cowling vertically onto the engine until it sits evenly on the seal on the lower cowling.
- To engage the latches, turn the lock knobs (1) on the front and back clockwise as far as they will go.
- Finally check that the cowling is fixed in place.

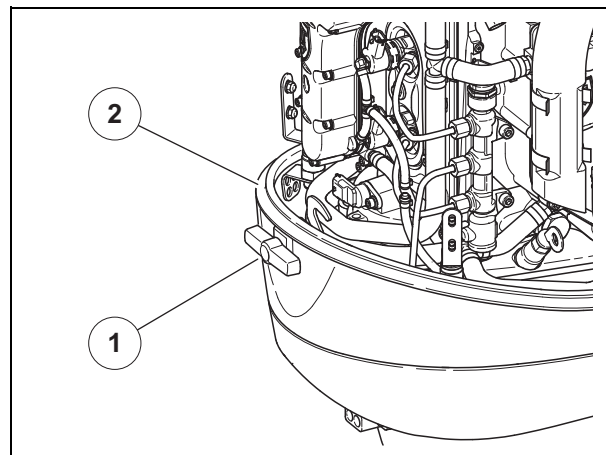

Preparing for operation

Before each operation

Carry out the following steps before operating the engine:

- Visual inspections and checks (page 116)
- Inspecting the safety features (page 116)
- Checking the oil fill level (page 118)
- Emptying the water separator (page 126)
- Emptying the water separator in the fuel feed line (page 130)

Refueling



WARNING

Danger of fire due to fuel.

Diesel fuel spills or leaks can be ignited on very hot surfaces or next to open flames, which can result in serious burns.

- Only refuel with the engine switched off.
- Never refuel near open flames or hot surfaces.
- No smoking.
- Make sure you do not spill any fuel.
- Do not overfill the tank.



WARNING

Danger of reduced maneuverability due to incorrect fuel.

The outboard engine must be capable of starting up at low temperatures, otherwise there is a danger of reduced maneuverability of the boat.

At low atmospheric temperatures (under 0 °C), winter diesel must be used. Observe the supplier or vendor specifications.



CAUTION

Danger of slipping due to fuel spills.

If any fuel is spilled on the floor, there is a danger that people can slip, fall over and suffer serious injuries.

Clean up any spilled or leaking fuel immediately and clean and dry the affected areas thoroughly.

NOTICE**Risk of damage to the engine due to incorrect fuel.**

Only use approved diesel fuels (see *Technical data* from page 171 onwards).

The use of biodiesel is not permitted.

NOTICE**Danger of environmental damage due to fuel spills.**

Do not overfill the tank and make sure you do not spill any fuel.

If any fuel leaks, clear it up immediately and dispose of it in an environmentally friendly way.

When possible, do not refill a portable tank on board the boat in order to prevent fuel spills from soiling the boat and resulting in a risk of slipping.

Do not fill more than the permitted amount of fuel into the tank, as the fuel can expand at high ambient temperatures and start to come out of the ventilation hole.

- Stop the outboard engine, switch it off and ensure it cannot restart by removing the ignition key, for example.
- Always have an absorbent cloth nearby so that you can clean up any fuel which may be spilled.
- Open the tank cap and fill the tank slowly and evenly up to the maximum filling level marked.
- Clean up any spilled fuel immediately and clean and dry the affected areas thoroughly.
- Close the tank cap and ensure it is tight.
- Clean the surrounding area thoroughly.

Connecting the kill switch lanyard



WARNING

Danger due to sudden engine cut-out.

Accidental activation of the stop button by the kill switch lanyard can result in passengers losing their balance and even falling overboard.

Sudden stopping of the engine can result in loss of control of the boat and to possible danger situations when landing, departing or swerving.

The kill switch lanyard (1) can be attached to the skipper's body, e.g., to the wrist.

If the skipper goes overboard, the clip attached to the kill switch lanyard is pulled out of the stop button (1), which immediately cuts off power to the outboard engine. This can prevent or minimize the possibility of injuries caused by the propeller.

If there is more than one person on board, it must be possible for the engine to be restarted if the skipper goes overboard with the kill switch lanyard. A second, easily accessible kill switch lanyard with a clip is one possibility.

The kill switch lanyard must give the skipper enough room to move but must not be too long and should not become caught on any other parts of the boat. It may become necessary to shorten the kill switch lanyard depending on the position of the skipper.

Before starting up the engine, check that the kill switch lanyard is working properly by moving away from the outboard engine. The clip on the kill switch lanyard must release from the stop button as soon as you reach a certain distance.

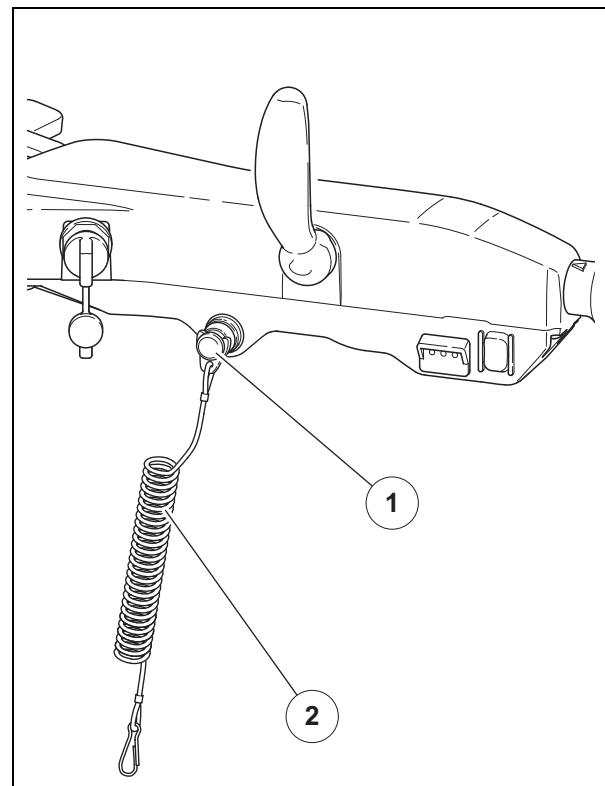

Start-up



WARNING

Danger due to uncontrolled operation.

At least one person must always be available to operate and to stop the engine, either directly via the tiller handle or via the control box, before start-up and whenever the outboard engine is running.

Normal start

Tiller handle

- Open the ventilation screw on the tank.
- If equipped, open the valves in the fuel lines between the tank and the outboard engine.
- Insert the ignition key (into the tiller handle ignition switch (1) when operating with a tiller handle).
- Place the shift lever on the tiller handle (2) into the neutral position.
- Turn the throttle grip (3) on the tiller handle clockwise as far as it will go (idling setting).
- Turn the ignition key to the first stop. The indicators (4) on the tiller handle will light up for a moment.
- Once the indicators have gone out, continue to turn the ignition key against the resistance and hold it in place until the engine starts.
- As soon as the engine is running, release the ignition key.

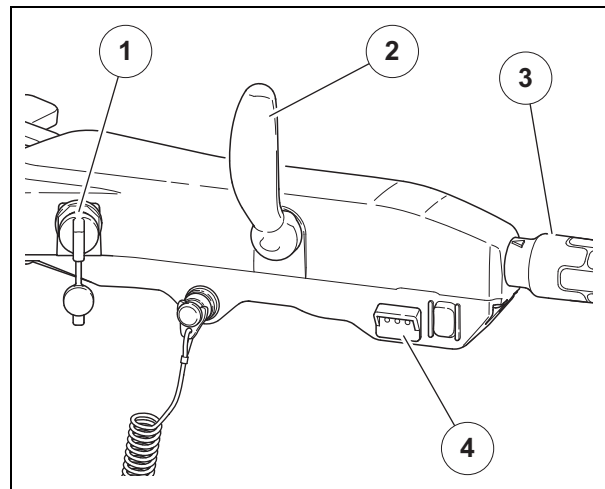

Control box

- Open the ventilation screw on the tank.
- If equipped, open the valves in the fuel lines between the tank and the outboard engine.
- Insert the ignition key (into the control box ignition switch (3) when operating with a control box).
- Place the shift and throttle lever (1) on the control box into the neutral position.
- Close the throttle lever for warm-up (2).
- Turn the ignition key to the first stop.
- Then, continue to turn the ignition key against the resistance and hold it in place until the engine starts.
- As soon as the engine is running, release the ignition key.

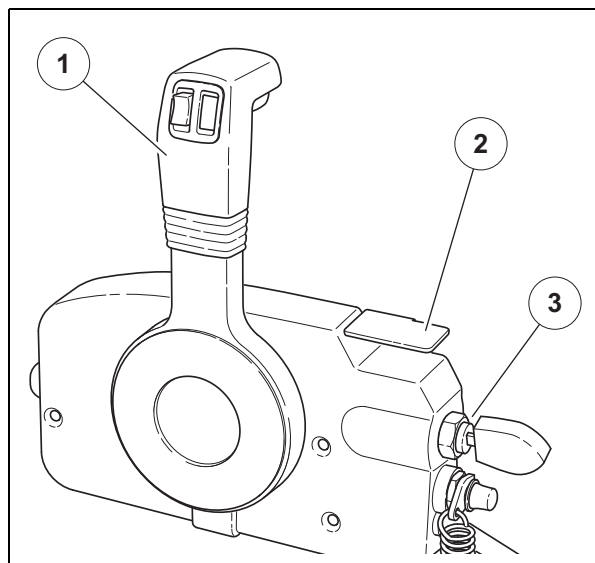

Special preparations for the first start

Before starting the outboard engine for the first time, such as at initial operation, after reassembly or after work on the fuel system, the fuel system must first be bled and filled with fuel.

For more information about the first start, refer to the information supplied with the fuel filter.

If the recommended fuel filter is used, proceed as follows:

- Open the ventilation screw on the tank.
- If equipped, open the valves in the fuel lines between the tank and the outboard engine.
- Turn the white handle of the hand primer out of the filter housing.
- Operate the hand primer 10 times.
- Turn the ignition key to the first stop. The indicators on the tiller handle will light up for a moment and the pre-feed pump of the outboard engine will operate.
- Operate the hand primer another 20 times.
- Confirm whether fuel is coming out of the return line in the tank.
- If necessary, continue pumping until fuel comes out of the return line.
- Turn the white handle of the hand primer into the filter housing.
- Proceed as for a normal start.

Travel



DANGER

Life-threatening danger due to rotating propeller.

With the engine running, there is a danger of extremely serious injuries due to the sharp edges of the rotating propeller.

Never leave the boat with the engine running.

Observe the breaking-in instructions during the breaking-in phase (see page 77).

Controlling the engine speed

Tiller handle

When operating the outboard engine with the tiller handle, the engine speed can be adjusted by turning the throttle grip (1).

- Turn the throttle grip clockwise in order to reduce the engine speed.
- Turn the throttle grip counterclockwise in order to increase the engine speed.

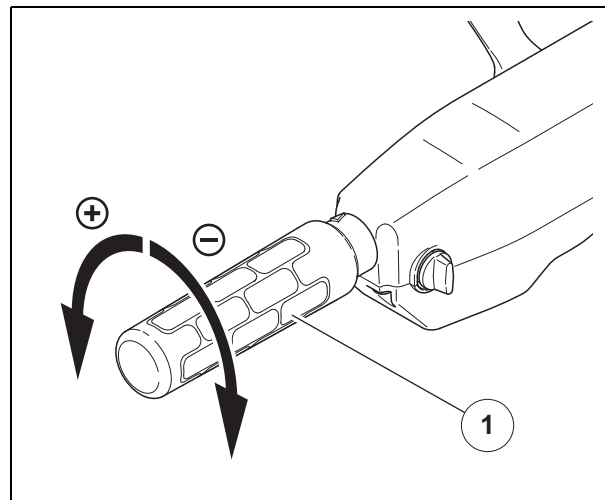

Control box

When controlling the outboard engine with the control box, control the speed with the shift and throttle lever (2) or with the throttle lever for warm-up (3).

When increasing the speed with the throttle lever for warm-up, the gear remains disengaged and the propeller does not rotate.

- Completely close the throttle lever for warm-up.
 - Before moving the shift and throttle lever, press the button for releasing the neutral lock (1).
 - Move the shift and throttle lever forward or backward to increase the engine speed.
 - Move the shift and throttle lever toward the neutral position (**N**) to reduce the engine speed.
-
- Before opening the throttle lever for warm-up, move the shift and throttle lever into the neutral position (**N**).
 - Open the throttle lever for warm-up upward to increase the engine speed.
 - Close the throttle lever for warm-up downward to reduce the engine speed.

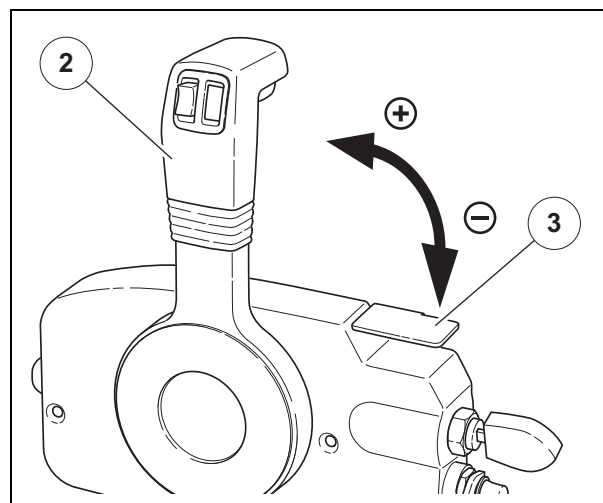
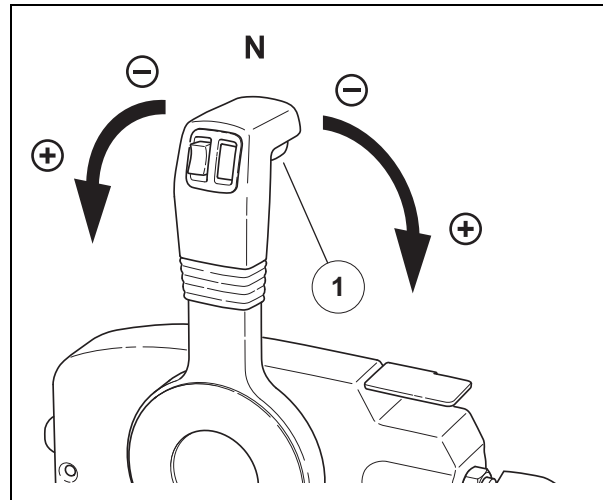

Changing gears with the tiller handle



WARNING

Danger due to loss of control.

Never change gears at high engine speed. Changing the gear at high engine speed can result in unexpected movement of the outboard engine and the boat. This can result in personal injury and serious damage to the outboard engine.

Only change the gear when the engine is at the lowest speed.

Forward motion

- Turn the throttle grip (2) on the tiller handle clockwise in order to reduce the engine speed.
- Once the idling speed has been reached, push the shift lever (1) as far as it will go in the direction of the bow.
- Turn the throttle grip counterclockwise in order to resume travel and accelerate.
- Before shifting into the neutral position, turn the throttle grip clockwise in order to reduce the engine speed.

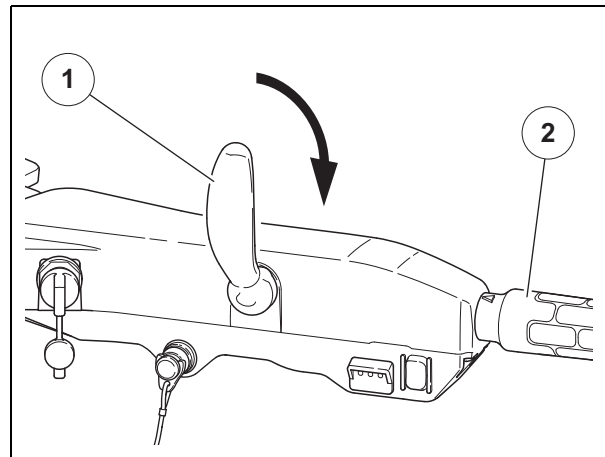

Changing over

Once the idling speed has been reached, you can shift between forward and reverse in one movement without stopping in the neutral position.

- Turn the throttle grip (2) on the tiller handle clockwise in order to reduce the engine speed.
- Once the idling speed has been reached, move the shift lever (1) in the opposite direction as far as it will go.
- Turn the throttle grip counterclockwise in order to resume travel and accelerate.

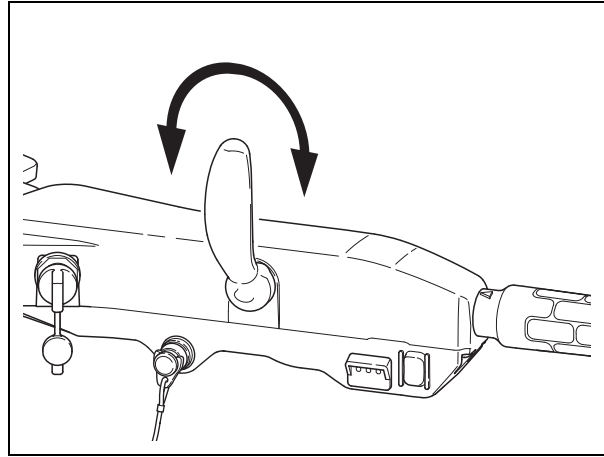

Reversing

- Turn the throttle grip (2) on the tiller handle clockwise in order to reduce the engine speed.
- Once the idling speed has been reached, move the shift lever (1) as far as it will go in the direction of the stern.
- Turn the throttle grip counterclockwise in order to resume travel and accelerate.

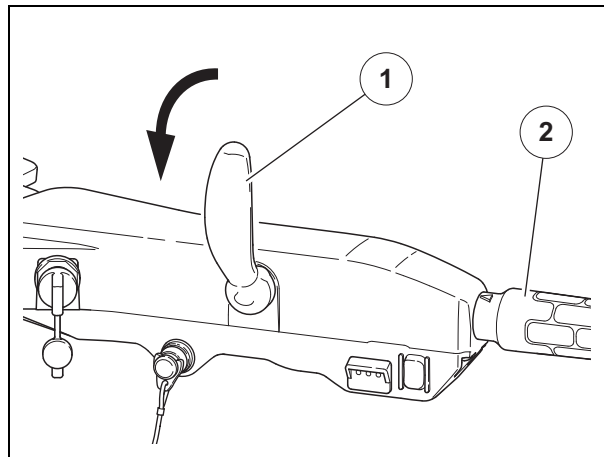

When reversing with a certain dynamic pressure on the propeller, the exhaust gases come out the back of the outboard engine rather than through the propeller under the water (see page 31).

The maximum speed cannot normally be achieved in reverse.

Changing gears with the control box



WARNING

Danger due to loss of control.

Never change gears at high engine speed. Changing the gear at high engine speed can result in unexpected movement of the outboard engine and the boat. This can result in personal injury and serious damage to the outboard engine.

Only change the gear when the engine is at the lowest speed.

Forward motion

- Before moving the shift and throttle lever, press the button for releasing the neutral lock (1).
- Move the shift and throttle lever in the direction of the bow to begin forward travel and to accelerate.

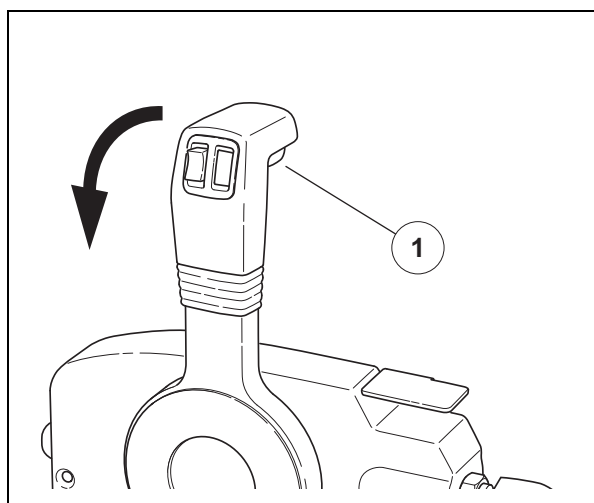

Changing over

When shifting between forward and reverse, briefly keep the shift and throttle lever in the neutral position (**N**) to allow the outboard engine to drop to idling speed.

- Move the shift and throttle lever into the neutral position (**N**) to reduce the engine speed.
- Once the idling speed has been reached, shift into forward or reverse.

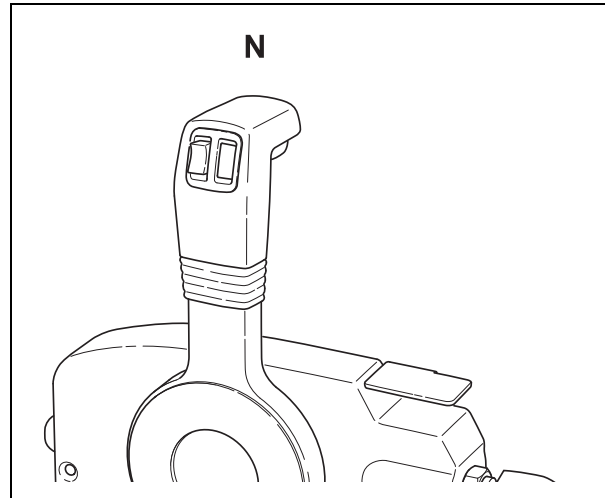

Reversing

- Before moving the shift and throttle lever, press the button for releasing the neutral lock (1).
- Move the shift and throttle lever in the direction of the stern to begin reverse travel and to accelerate.

When reversing with a certain dynamic pressure on the propeller, the exhaust gases come out the back of the outboard engine rather than through the propeller under the water (see page 31).

The maximum speed cannot normally be achieved in reverse.

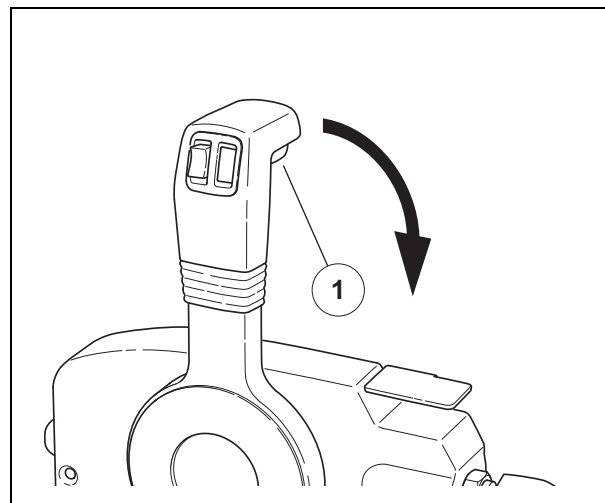

Steering



WARNING

Danger due to sudden movements.

Sudden movements when steering can result in passengers losing their balance and even falling overboard.

Sudden movements when steering at high speed can lead to a loss of control of the boat. This can result in an accident and injury to persons.

Always steer the boat carefully so that you can control its movements correctly.

The boat can be steered by moving the outboard engine in the direction opposite to where you want to go.

The outboard engine can either be controlled directly with the tiller handle or with the boat's steering wheel.

- Move the tiller handle toward the port side of the boat to change the direction to starboard (A).
- Move the tiller handle toward the starboard side of the boat to change the direction to port (B).

If you are operating the outboard engine with a steering wheel and steering linkage, ensure that you refer to all the additional information supplied together with the steering wheel and linkage.

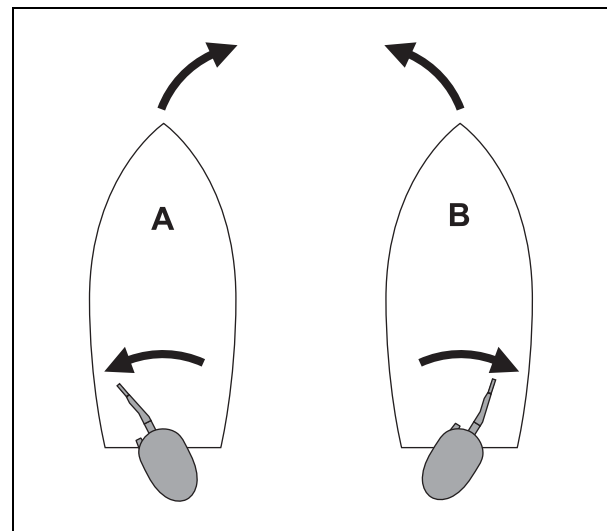

Holding the steering resistance



WARNING

Danger of loss of control due to held steering.

The steering resistance is not intended for the boat to be steered without tiller handle operation.

Even when the steering resistance is held, always keep one hand on the tiller handle in order to be able to maneuver the boat at any moment.

The steering resistance is only intended to help you maintain the tiller handle in the desired steering position.

- Set the lever (1) all the way to starboard, which is the holding position. The tiller handle should now stay in the same position but can still be moved.
- Move the lever (1) all the way to port. The tiller handle should now move without any resistance.
- If the tiller handle stays in the holding position too tightly, you may need to adjust the steering resistance (see page 72).

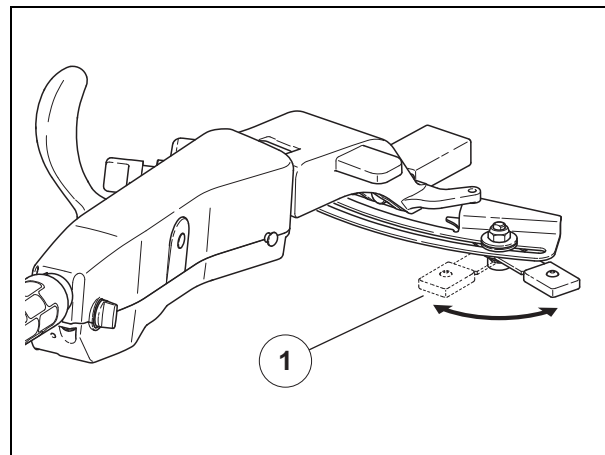

Trimming using the power trim



WARNING

Danger due to insecure position.

During travel, only use the trim switch on the tiller handle or in the cockpit of the boat to operate the power trim.

Operating the trim switch on the cowling leads to insecure positioning and can result in the operator going overboard.

The outboard engine is fitted with a power trim (see page 26). With it, you can tilt the outboard engine into the ideal trimming angle when traveling.

A correct trimming angle results in a stable position of the boat and reduced steering effort. The trim is neutral when the propeller axis is completely horizontal. As this position offers the greatest efficiency, a well-trimmed boat can travel faster and save energy.

- Push the trim switch on the tiller handle or control box up (1) in order to tilt the outboard engine upward.
- Push the trim switch down (2) to tilt the outboard engine downwards.

Trimming the outboard engine too far down will cause “plowing”. The bow dips too low into the water.

Trimming the outboard engine too far up can cause the boat to pound on the waves. The bottom of the boat can slam forcefully onto the surface of the water. In extreme cases, this can result in loss of control of the boat.

Note the instructions on how to travel in shallow water with a tilted outboard engine (see page 97).

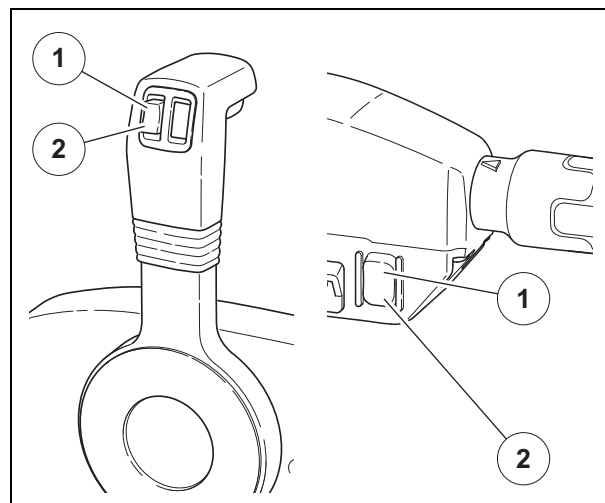

Economical operation

Operate the engine in as economical a way as possible. This will reduce wear on the engine and fuel consumption, and is better for the environment.

- Choose an engine speed at which the boat runs comfortably and quietly.
- Change the engine speed as little as possible.
- Do not operate at the highest engine speed if the engine has not warmed up.
- Do not attempt to accelerate further once the final speed of a displacement boat has been reached.
- Keep the boat in the ideal position using the power trim.

Shallow water operation

NOTICE

Reduced cooling water due to tilted outboard engine.

If the cooling water inlet is too high, a lack of cooling water can result in the outboard engine overheating.

Observe the following instructions when traveling in shallow water:

- Only tilt the outboard engine slightly so as not to affect the uptake of cooling water.
 - Do not travel in reverse with a tilted outboard engine in order to ensure that the cooling water inlet (see page 27) remains under water.
-
- Using the power trim (see page 96), tilt the outboard engine upwards so that the propeller does not come into contact with the bed or with any stones.
 - Return the outboard engine to the normal position as soon as possible.

Traveling slowly



WARNING

Risk of discharged battery.

If the battery becomes discharged, the engine cannot be started anymore and the boat cannot be maneuvered.

Ensure that the battery never completely discharges when traveling slowly.

At low engine speeds, the battery is no longer recharged by the outboard engine alternator. Charging starts at a speed of $1,000 \text{ min}^{-1}$.

At slow speeds, the battery is discharged by the power consumers in the outboard engine. For this reason, slow travel (for example, when trolling) must be limited to a maximum of 3 hours. After this time, the battery must be recharged by traveling at a higher engine speed.

When the battery charge is too low, a warning signal is sounded and the charging indicator (1) comes on.

- Immediately start traveling at a high outboard engine speed in order to recharge the battery.

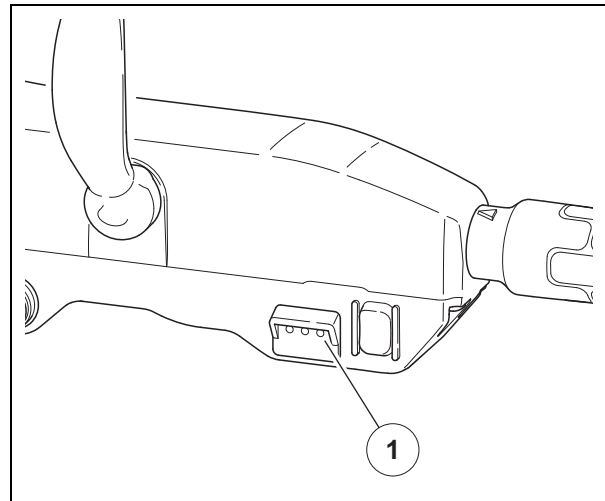

Checking operational safety during travel

Check the operational safety of the outboard engine during travel:

- Ensure that the anti-cavitation plate (2) and cooling water inlets (3) remain under water at any engine speed and in any trim position. Otherwise, the engine may overheat due to the lack of cooling water.
- Ensure that the outboard engine is not submerged too low. The increased resistance from the water can result in a drop in performance.
- Avoid water entering the engine compartment under the cowl for too long. Every now and again, check that any water that has entered comes out through the openings in the lower cowling (1).

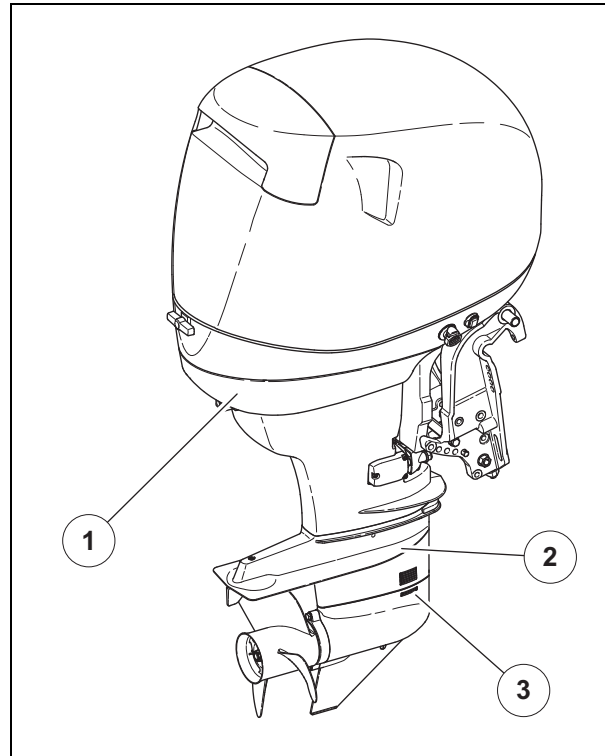

Heed warning signals

Heed any signals coming from the indicators.

Stop the outboard engine as soon as possible if the oil fill level is too low or if the oil temperature is too high (see page 109).

Ensure that the cause of the fault has been resolved before starting the outboard engine again.

If the charging indicator (4) comes on, increase the speed of the engine in order to recharge the battery.

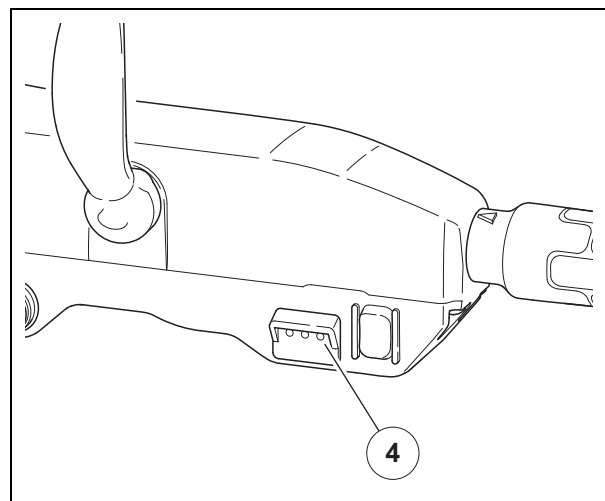

Stopping

Tiller handle

Before stopping the outboard engine, first of all reduce the engine speed and put the shift lever into the neutral position (see page 90).

- Turn the throttle grip clockwise as far as it will go (idling speed).
- Put the shift lever in the neutral position (**N**).
- Turn the ignition key counterclockwise. The engine switches off.
- Close the ventilation screw on the tank.
- If equipped, close the valves in the fuel lines between the tank and the outboard engine.

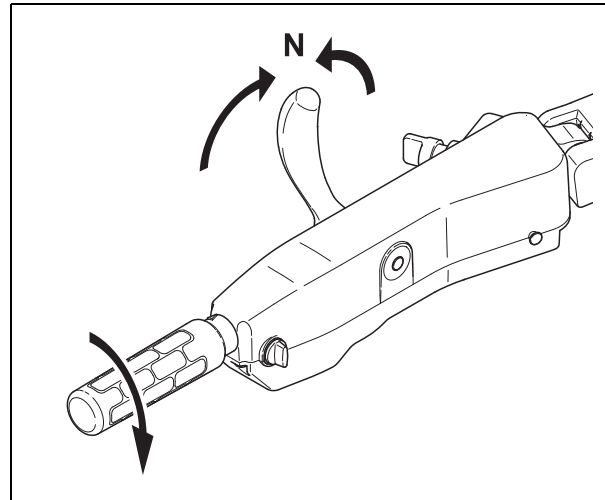

Control box

Before stopping the outboard engine, first of all reduce the engine speed and put the shift and throttle lever into the neutral position (see page 92).

- Put the shift and throttle lever into the neutral position (**N**).
- Turn the ignition key counterclockwise. The engine switches off.
- Close the ventilation screw on the tank.
- If equipped, close the valves in the fuel lines between the tank and the outboard engine.

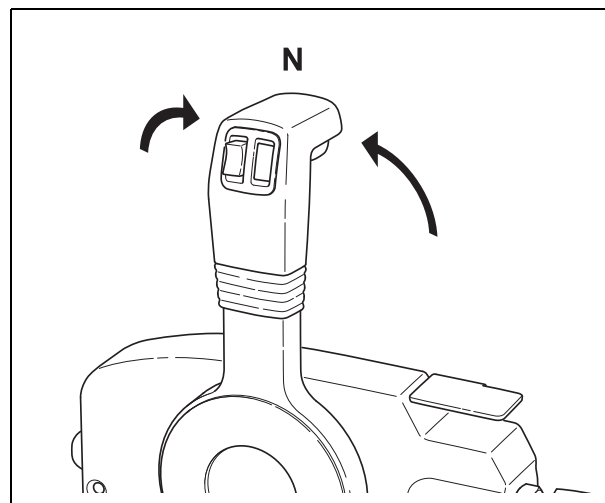

Ending operation

Tilting

With the outboard engine stopped, you can use the power trim to tilt it up until it is completely out of the water.

With the outboard engine in the raised position, you can protect it against tilting down.

- Push the trim switch on the tiller handle or control box up (see page 96) in order to tilt the outboard engine upward.
- Alternatively, you can use the trim switch (1) on the cowling.

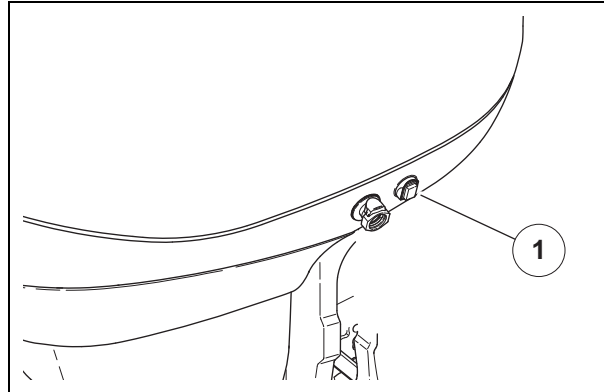

- Once the outboard engine is tilted up completely, move the safety catch (2) down.
- Push the trim switch down briefly in order to lower the outboard engine onto the safety catch.

Attention! Ensure that you have lifted the safety catch before you attempt to tilt the outboard engine down again.

- Push the trim switch on the tiller handle or control box up (see page 96) in order to slightly tilt the outboard engine upward.
- Move the safety catch (2) up.

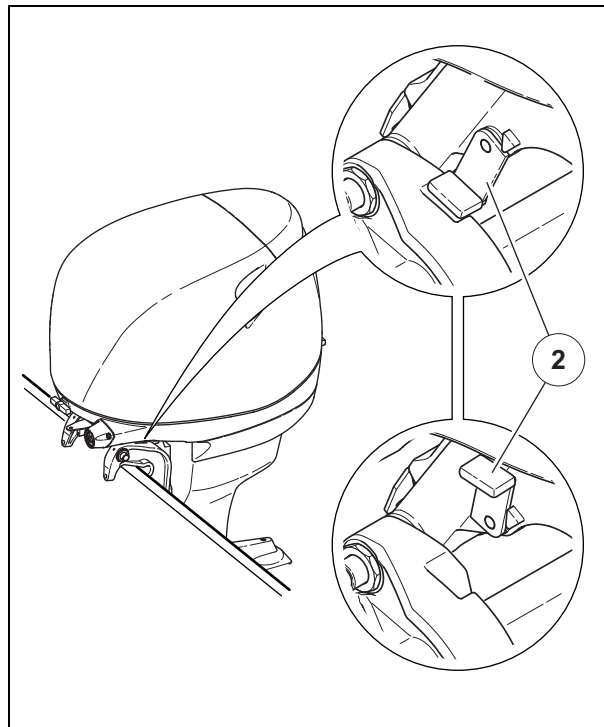

Switching off

Tiller handle

- Remove the ignition key (2) from the ignition switch to disconnect all the electrical consumers and to prevent the engine from starting up again.
- Cover the ignition switch with the protective cap (1).

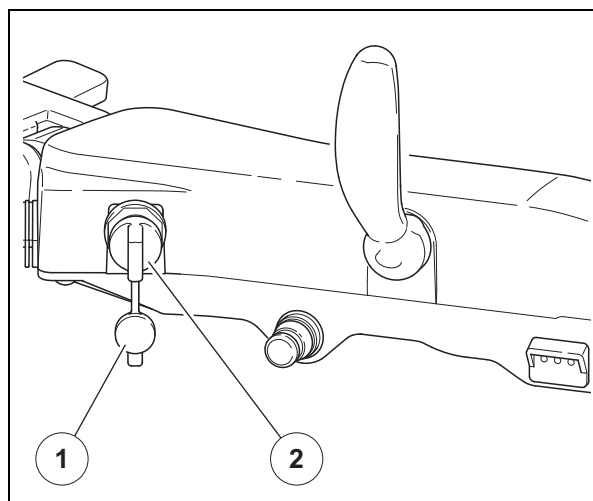

Control box

- Remove the ignition key (3) from the ignition switch to disconnect all the electrical consumers and to prevent the engine from starting up again.

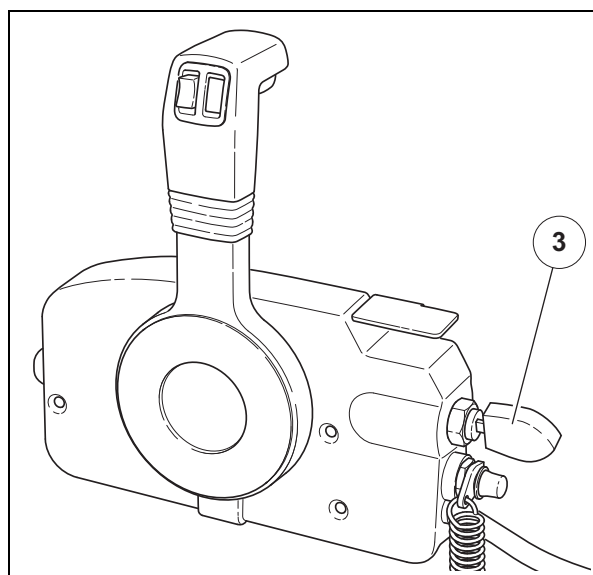

After every operation

Carry out the following steps after each time you use the engine:

- Flushing the cooling circuit (page 124)
- Checking the propeller (page 119)
- Checking the sacrificial anodes (page 120)

Faults

The following table shows a range of possible faults, what the cause might be, and how they might be resolved.

Also refer to the description of the engine protection functions (see page 111).

Troubleshooting table

Fault	Possible cause	Recommended solution
The engine does not start.	No fuel in the tank.	Fill up the tank.
	The fuel filter in the feed line from the tank is not filled with fuel.	Fill the fuel filter in the feed line from the tank with fuel (see page 87).
	The fuel filter in the feed line from the tank is clogged. The maintenance interval may have been exceeded (see page 122).	Replace the fuel filter element (see page 130).
	The engine fuel filter is clogged. The maintenance interval may have been exceeded (see page 122).	Replace the fuel filter element (see page 128).
	The clip on the kill switch lanyard has not been properly inserted into the stop button.	Make sure that the clip is properly inserted into the kill switch (see page 84).
	The shift lever is not in the neutral position (see page 35 and page 39).	Check the position of the shift lever.
	The control cables for the shift and throttle levers are out of adjustment, loose or torn.	Check the connection (see page 63) and adjustment (see page 69) of the control cables. Have a damaged control cable taken care of by a workshop.
	The battery is discharged.	Jump, charge or replace the battery when it is no longer chargeable.

Fault	Possible cause	Recommended solution
<p>The engine does not start.</p>	<p>The battery is disconnected.</p>	<p>Check the setting of the battery main switch. Check all battery leads and connections.</p>
	<p>The engine is started incorrectly.</p>	<p>Start the engine according to the instructions (see page 85).</p>
	<p>Engine damage.</p>	<p>Contact a workshop.</p>
	<p>At least one fuse is defective.</p>	<p>Check the fuses, identify and eliminate the cause of any defects, and then replace the affected fuse (see page 152).</p>
<p>During idling, the engine operation is not regular or the engine cuts out completely.</p>	<p>The fuel system is blocked, such as by kinks in a fuel line.</p>	<p>Check all fuel lines for kinks and squeezed sections.</p>
	<p>The fuel is contaminated.</p>	<p>Empty and clean the tank, and then fill it with fresh, clean fuel.</p>
	<p>The fuel filter in the feed line from the tank is clogged. The maintenance interval may have been exceeded (see page 122).</p>	<p>Replace the fuel filter element (see page 130).</p>
	<p>The engine fuel filter is clogged. The maintenance interval may have been exceeded (see page 122).</p>	<p>Replace the fuel filter element (see page 128).</p>
	<p>A fuel other than the specified engine oil was used (see page 173).</p>	<p>Check the engine oil used. Drain the engine oil that does not meet specification and fill in fresh oil of the specified type (see page 137).</p>

Fault	Possible cause	Recommended solution
During idling, the engine operation is not regular or the engine cuts out completely.	The fuel pump is defective.	Contact a workshop.
	The fuel feed and return lines are not connected correctly.	Check the connection of the fuel lines (see page 67).
	The battery is poorly or incorrectly connected.	Check all lead connections between the battery and the engine for any looseness and poor contact.
The engine switches to emergency operation.	The maintenance interval for the roller tappet has been exceeded (see page 122).	Immediately contact a workshop. Display the fault code (see page 109) or have it displayed.
	The cooling water temperature is too high.	Immediately contact a workshop. Display the fault code (see page 109) or have it displayed.
	The oil temperature is too high.	Immediately contact a workshop. Display the fault code (see page 109) or have it displayed.
	The cooling water pressure is too low.	Trim the outboard engine so that sufficient cooling water can enter (see page 99). Check the cooling water inlets (see page 31) for contamination or blockage. Contact a workshop. Display the fault code (see page 109) or have it displayed.
	A sensor is defective.	Immediately contact a workshop. Display the fault code (see page 109) or have it displayed.

Fault	Possible cause	Recommended solution
The engine loses power.	The propeller is damaged.	Check the propeller for damage and replace it if necessary (see page 145).
	The mounted propeller does not meet the specification (diameter and pitch).	Replace the propeller (see page 145) to operate the outboard engine at the recommended speed.
	The outboard engine has not been mounted to the correct height (see page 47).	Check the position of the outboard engine and correct it if necessary.
	Algae or other foreign materials are wrapped around the propeller.	Remove the algae and other foreign materials and clean the leg of the outboard engine.
	The fuel system is blocked, such as by kinks in a fuel line.	Check all fuel lines for kinks and squeezed sections.
	The fuel is contaminated.	Empty and clean the tank, and then fill it with fresh, clean fuel.
	The fuel filter in the feed line from the tank is clogged. The maintenance interval may have been exceeded (see page 122).	Replace the fuel filter element (see page 130).
	The engine fuel filter is clogged. The maintenance interval may have been exceeded (see page 122).	Replace the fuel filter element (see page 128).
The engine generates unusual noises.	Possible mechanical damage.	Immediately contact a workshop.
The engine pings during start-up.	Normal operating noise when starting.	No action required.

Fault	Possible cause	Recommended solution
Odors emanating from the outboard engine.	Leak in a fuel line or oil line.	Check all fuel and oil lines for leaks. Contact a workshop.
The leg shows significant external damage.	Outside impact such as from grounding.	Contact a workshop.
Increased fuel consumption	Leak in a fuel line.	Check all fuel lines for leaks. Contact a workshop.
Increased fuel consumption	Incomplete fuel combustion.	Contact a workshop.
Oil leaking.	Leak in an oil line.	Contact a workshop.
The engine indicator (see page 36) is continuously illuminated.	Engine damage.	Immediately contact a workshop. Display the fault code (see page 109) or have it displayed.
Black smoke emanating.	Engine damage.	Immediately contact a workshop. Display the fault code (see page 109) or have it displayed.
When changing from full load to idling, the exhaust outlet (see page 31) briefly emits white steam.	Normal transient development of steam.	No action required.
At start-up, the exhaust outlet (see page 31) briefly emits white steam.	Normal transient development of steam.	No action required.

Fault	Possible cause	Recommended solution
The outboard engine cannot be stopped or switched off.	Engine damage.	Shut off the fuel supply, disconnect the battery from the battery main switch. Immediately contact a workshop. Display the fault code (see page 109) or have it displayed.
Salt deposits.	Normal effect of operation in salt water or brackish water.	Clean the outboard engine regularly (see page 114). Attention! Do not use a high-pressure cleaner!
Surface rust on the turbine housing of the turbo charger.	Normal effect of operation in salt water or brackish water.	No action required.
The performance of the power trim drops.	Low hydraulic oil level in power trim.	Refill hydraulic oil (see page 142)
The outboard engine cannot be trimmed.	The trim switch is defective, such as from a loose connection.	Check the trim switch. Contact a workshop.
	The trim switch is clogged with foreign material.	Check the trim switch. Contact a workshop.
	Leak in the hydraulic system.	Check the power trim for hydraulic oil leaks. Contact a workshop.
The cowl cannot be locked.		Readjust the cowl lock (see page 155).
The flushing connector is loose.	The screw connections have become loose.	Tighten the screws.

Fault codes

When the engine indicator (see page 36) is continuously illuminated due to a fault, you can display the fault code.

A fault code consists of 4 digits displayed by successive engine indicator flashing sequences separated by a short pause. Example: 4 flashes indicate a 4; 8 flashes indicate an 8.

Alternatively, the 4 digits are indicated acoustically.

If several fault codes are stored in memory, you can display them one by one. To do so, simply repeat the process. If an error code is displayed again, no further error codes are stored in memory. If the first error code is displayed again, it is the only error code stored in memory.

A maximum of 10 error codes are stored in memory and can be displayed one by one.

Example: only 1 fault code stored



Example: 2 fault codes stored

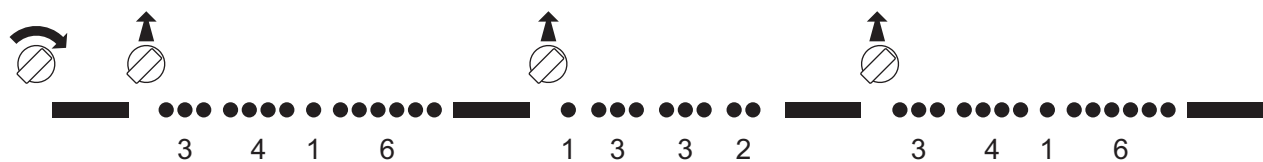

Displaying fault codes

- Stop the outboard engine and wait at least 30 seconds.
- Then, turn the ignition key to the first stop. The engine indicator illuminates continuously and the acoustic signal sounds.
- Briefly press the ignition key into the ignition switch. The engine indicator flashes to display the fault code. Alternatively, the fault code is indicated acoustically. The engine indicator returns to being continuously illuminated.
- Briefly press the ignition key into the ignition switch to display the next fault code.

Engine protection functions

The following engine protection functions with regard to oil temperature, cooling water temperature, oil pressure, cooling water pressure and boost pressure may be implemented by the system to reduce performance.

When the limits are no longer exceeded, the engine performance will be fully reestablished.

Oil temperature

At oil temperatures from 146 °C to 153 °C, the injection quantity, and therefore the output power, will be reduced following a linear ramp.

Up to 146 °C, 100% of the injection quantity requested by the operator via the throttle lever will be applied.

From 153 °C, 40% of the injection quantity requested by the operator via the throttle lever will be applied.

Since the temperature behavior is not overly dynamic, the engine will typically remain stationary along the ramp or follow a hysteresis.

The engine will never be automatically switched off at temperatures above 153 °C. Starting the engine remains possible in those circumstances.

Cooling water temperature

At cooling water temperatures from 73 °C to 80 °C, the injection quantity, and therefore the output power, will be reduced following a linear ramp.

Up to 73 °C, 100% of the injection quantity requested by the operator via the throttle lever will be applied.

From 80 °C, 40% of the injection quantity requested by the operator via the throttle lever will be applied.

Since the temperature behavior is not overly dynamic, the engine will typically remain stationary along the ramp or follow a hysteresis.

The engine will not be automatically switched off at temperatures above 80 °C. Starting the engine remains possible in those circumstances.

Oil pressure

The data set applies a minimum oil pressure curve. If the actual oil pressure drops below the minimum, the engine will be operated in the emergency mode LVL2 (performance reduced to 75 Nm).

Once the oil pressure rises above the minimum again, the engine performance will be fully reestablished.

The engine will never be automatically switched off at low oil pressure. Starting the engine remains possible in those circumstances.

The control unit establishes the fault, which will be displayed by the engine indicator (see page 109).

Fault code = 1312

DTC = P0524, SPN = 100, FMI = 1

Cooling water pressure

If the cooling water pressure drops below 200 mbar relative at engine speeds of $\geq 2,000$ 1/min, the engine will be operated in the emergency mode LVL2 (performance reduced to 75 Nm).

Once the values have returned to normal (such as by removing any contamination or blockage from the cooling water inlets), the engine performance will be fully reestablished.

The engine will never be automatically switched off at low cooling water pressure. Starting the engine remains possible in those circumstances.

The control unit establishes the fault, which will be displayed by the engine indicator (see page 109).

Fault code = 1116

DTC = P05C3, SPN = 109, FMI = 1

Boost pressure

To protect the turbo charger at boost pressures of > 1.6 bar relative, the engine will be operated in the emergency mode LVL1 (performance reduced to 95 Nm).

When the limit is no longer exceeded, the engine performance will be fully reestablished.

The engine will never be automatically switched off when boost pressure is exceeded. Starting the engine remains possible in those circumstances.

The control unit establishes the fault, which will be displayed by the engine indicator (see page 109).

Fault code = 1414

DTC = P226B, SPN = 1127, FMI = 0

Maintenance

Maintenance tasks

The operator of the outboard engine must be familiar with the relevant provisions regarding maintenance tasks and follow them at all times.

The maintenance tasks include the following:

- Cleaning
- Inspection
- Service
- Repairs

The skipper is responsible for carrying out all safety checks and ensuring that all lubrication and maintenance tasks are observed in order to ensure safe operation.

Follow all instructions regarding lubrication and maintenance. Regular appropriate maintenance and correct care of the outboard engine will keep it safe, prevent faults and limit the general operating costs.

As operator of the outboard engine, ensure that only qualified professionals carry out any maintenance or repair tasks.

Any work on the outboard engine which is not described in this owner's manual or in the workshop handbook must only be carried out by the Neander Shark customer service team.

Cleaning



CAUTION

Danger of slipping on cleaning fluids.

After completing all cleaning tasks, ensure that any remaining water or cleaning fluids are removed from the surrounding area and the ground. If any liquid is spilled on the floor, there is a danger that people can slip, fall over and suffer from serious injuries.

NOTICE

Risk of damage to the engine.

For cleaning, do not use any tools with a pointed or sharp edge and avoid the use of any aggressive or corrosive cleaning fluids. These can damage the surfaces and the paintwork.

Only the exterior of the outboard engine should be rinsed with clean water. If necessary, use a neutral cleaning fluid.

After every operation

Cooling circuit

After each operation of the outboard engine in salt water, brackish water or water polluted with chemicals, the cooling circuit must be flushed thoroughly with fresh water (see page 124).

Surfaces

Only the exterior of the outboard engine should be rinsed with clean water, especially after use in salt water, brackish water or water polluted with chemicals.

Do not remove the cowling cover, and ensure that no water can penetrate through it.

Regularly

Surfaces

The surfaces of the outboard engine must be kept clean at all times and cleaned regularly.

Do not use water to clean under the cowling. If necessary, remove any dirt with a dry or slightly moist cloth.

Lower cowling

There are several holes on the underside of the cowling to let out any water which may have entered.

When necessary, clean these holes so that they do not become blocked.

Inspection

Inspection intervals

The table shows the recommended intervals for inspections and other tasks. The page numbers refer to the descriptions of the different tasks.

The inspection intervals given in the table are valid for when the outboard engine is used under normal conditions.

If the outboard engine is used in more challenging conditions such as more frequent use at full speed or in muddy, silty, sandy, acidic or shallow water, the inspections may need to be carried out more frequently than indicated in the table. If the frequency of the inspections is not increased under such conditions, damage may occur.

Ask your dealer for information on inspections based on the conditions of your particular application.

Inspection interval	Task	Page
Before each operation	Visual inspections and checks	116
	Inspecting the safety features	116
	Checking the oil fill level	118
After every operation	Checking the propeller	119
	Checking the sacrificial anodes	120
	Make sure the fixing bolts of the transom are tight and undamaged	
	Check the water inlet of the leg	
	Check the cooling water inlets (see page 31) for contamination or blockage	

Visual inspections and checks

Ensure that the boat and the outboard engine are in good condition and prepared for emergencies. Carry out the following checks with particular care and attention:

- Ensure all 4 fixing bolts on the transom are tight and undamaged.
- Check the battery connections are tight.
- Check the fuel line between the tank on the outboard engine is tight and free from leaks.
- Move the outboard engine in both directions as far as it will go in order to check the steering.

If any of these checks shows any signs of damage or irregularity, do not start the outboard engine. Ensure that any issues are resolved before starting the outboard engine.

Inspecting the safety features

All the safety features must be checked regularly to ensure that they are operational. The safety features should also be inspected before each operation. In all cases, the following steps should be carried out:

- Locking the cowling (see page 116)
- Testing the stop button (see page 117)
- Testing the starter interlock (see page 117)

Locking the cowling

The cowling must be installed and locked before the outboard engine is started.

- Check the locking mechanism for damage and correct functioning.
- Install the cowling and lock it in place (see page 81).

Testing the stop button

You must check that the stop button is operational. It must not be possible to start up the outboard engine when the clip on the emergency shut-off cord is removed from the stop button.

- Remove the clip (1) from the stop button.
- Attempt to start up the outboard engine (see page 85).

It should not be possible to start up the outboard engine. If you are able to start up the engine even though the clip is released from the stop button, stop the outboard engine immediately and remove the ignition key. Take the engine to your dealer or to a specialized workshop for inspection and repair.

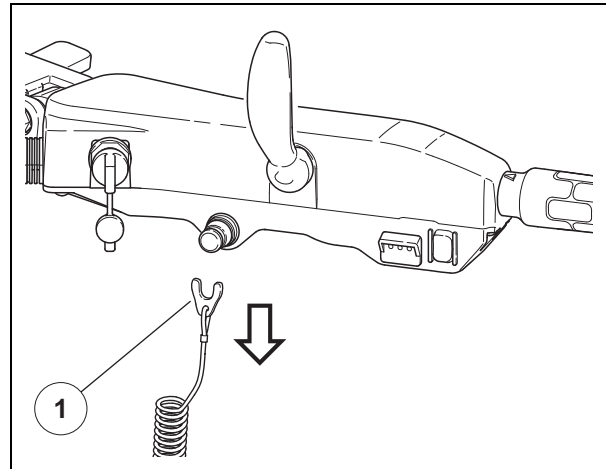

Testing the starter interlock

You must check that the starter interlock is operational. It should not be possible to start up the outboard engine if the shift lever is not in the neutral position.

- Move the shift lever (2) from the neutral position to the front position.
- Attempt to start up the outboard engine (see page 85).
- Move the shift lever from the neutral position to the back position.
- Attempt to start up the outboard engine (see page 85).

It should not be possible to start up the outboard engine. If you are able to start up the engine even though the shift lever is not in the neutral position, stop the outboard engine immediately and remove the ignition key. Take the engine to your dealer or to a specialized workshop for inspection and repair.

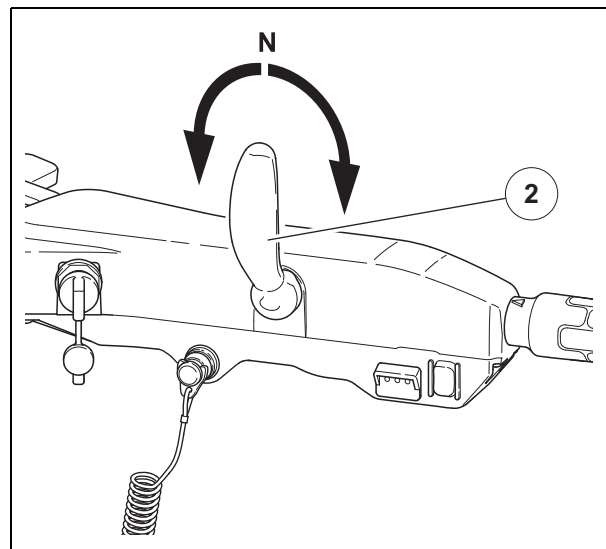

Checking the oil fill level

NOTICE

Risk of damage to the engine due to incorrect oil fill level.

Operating the outboard engine with an oil fill level under the MIN marking (1) or over the MAX marking (3) can lead to engine damage.

When checking the oil fill level, the outboard engine must be vertical (lowest tilting position) and stopped.

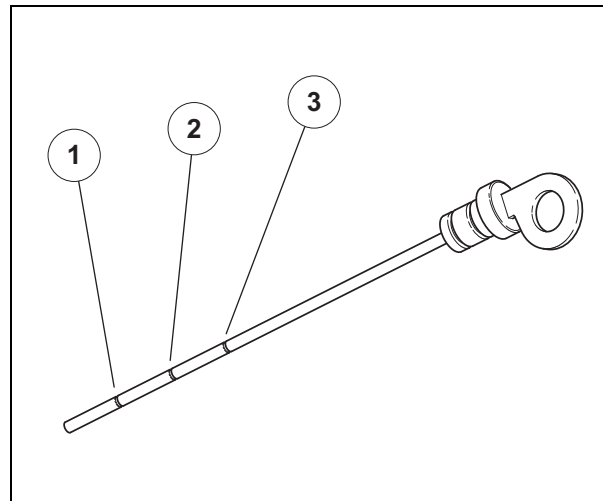

The oil fill level must lie between the MIN marking at the bottom (1) and the MAX marking at the top (3). The central marking (2) shows the ideal fill level.

The distance between the markings corresponds to approximately 0.5 liters of engine oil.

- Stop the outboard engine and ensure it cannot restart, by removing the ignition key, for example.
- Wait several minutes until the engine oil has settled in the crankcase.
- Remove the cowling (see page 81).
- Remove the dipstick (4) from the right-hand side of the engine and wipe with a clean cloth.
- Insert the dipstick as far as it will go, and then remove it once more.
- Check the oil fill level according to the markings on the dipstick.
- If the oil fill level is under or close to the MIN marking, top up the engine oil (see page 139), and then check the fill level once again.
- After completing your check, fully insert the dipstick.
- Install the cowling (see page 81).

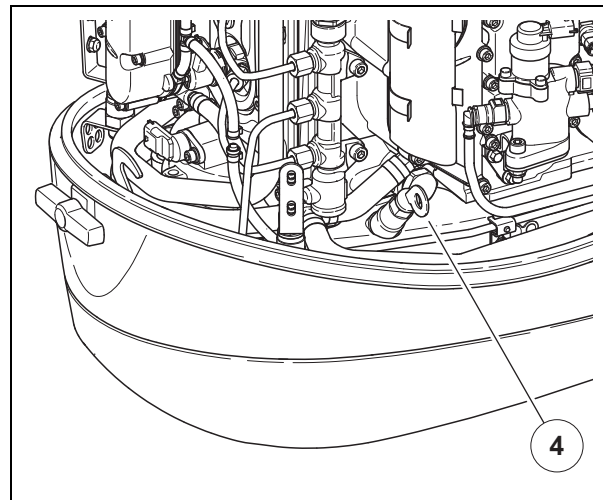

Checking the propeller

Visual inspection

Check the outboard engine propeller and all of the housing parts and components under the water line for visible damage (for example, cracks, deformation or discoloration).

If you detect any damage, the propeller must be replaced (see page 145).

Functional testing



DANGER

Life-threatening danger due to rotating propeller.

The propeller blades have very sharp edges. There is a very high danger of serious cuts from the propeller, which can even result in death.

Ensure that the outboard engine cannot restart when working on the propeller. One way of doing this is to remove the ignition key or the clip on the kill switch lanyard from the stop button.

There is even a risk of injury when the propeller is not rotating. Wear protective gloves.

- Tilt the outboard engine up using the power trim until it is completely out of the water (see page 101).
- Prevent the outboard engine from restarting, by removing the ignition key, for example.
- Check the propeller is firmly fixed in place.
- Turn the propeller manually. The propeller should turn easily and not grind.

Checking the sacrificial anodes



DANGER

Life-threatening danger due to rotating propeller.

The propeller blades have very sharp edges. There is a very high danger of serious cuts from the propeller, which can even result in death.

Ensure that the outboard engine cannot restart when working on the propeller. One way of doing this is to remove the ignition key or the clip on the kill switch lanyard from the stop button.

There is even a risk of injury when the propeller is not rotating. Wear protective gloves.

The sacrificial anode protects the metallic parts of the outboard engine from electrolytic corrosion.

Replace a sacrificial anode once it has been worn down by more than 1/3 of its original size (see page 149).

Check the sacrificial anodes in sequence:

- traw trim (1)
- under the transom (2)
- under the vibration damper (3)
- on the shaft (4)

There is one more sacrificial anode located on the cylinder head, however it is not accessible from the outside of the engine. There is a description of how to check and replace this anode in the workshop handbook.

- Tilt the outboard engine up using the power trim until it is completely out of the water (see page 101).
- Prevent the outboard engine from restarting, by removing the ignition key, for example.
- Check the sacrificial anodes.
- Check and retighten the fixing bolt on each sacrificial anode.

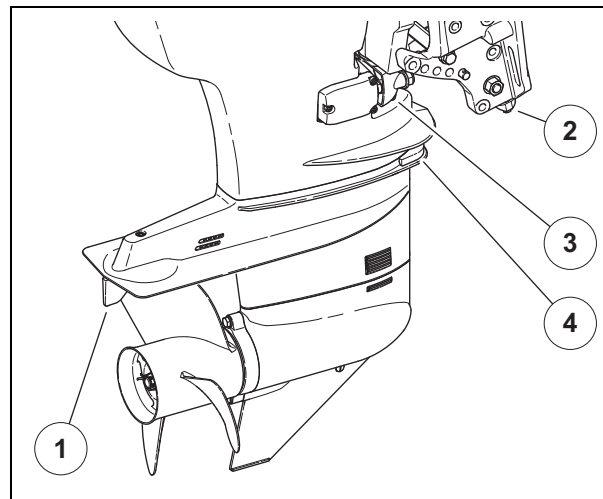

Checking the warning signs and information stickers

Ensure that all of the warning signs and information stickers on the outboard engine remain clearly legible. If a sign or sticker is no longer legible, it must be replaced with a new one containing the same information.

Pay special attention to all of the warning signs, the rating plate (see page 20) and the labels for connectors and controls.

Locations of warning signs and information stickers

The diagram shows two views of an outboard engine. Callouts point to various warning signs and information stickers. A circular sticker on the left indicates 'Motoröl einfüllen / Fill engine oil'. Two 'WARNING' signs are shown on the right, each with a book icon and a warning triangle icon. A table of fuses and relays is shown at the bottom left.

Motoröl einfüllen / Fill engine oil

FUSES	RELAYS
Spare 10A	
Spare 20A	Glow relay 2
Spare 30A	
Glow plug2 30A	Glow relay 1
Glow plug1 30A	
Main relay 30A	Main relay
Trim Switch 5A	
Fuel pump 20A	Fuel pump relay
Remote Control 10A	
Start Ready20A	Start relay

WARNING
Lesen Sie das Handbuch und die Aufkleber.
Um Verletzungen zu vermeiden, halten Sie Ihre Hände, Haare, Kleidung etc. vom laufenden Motor fern.
Beim Starten oder während des Betriebes berühren oder entfernen Sie keine elektrischen Bauteile.

WARNING
To avoid injury, read the owner's manual carefully before operating the engine.
To avoid injury when engine is running, keep your hands, hair, clothing etc. away from engine.
Do not touch or remove electrical parts when starting or during operating.

WARNING
Lesen Sie das Handbuch und die Aufkleber.
Tragen Sie eine Rettungsweste.
Verbinden Sie die Notstopleine mit Ihrer Rettungsweste. Ihrem Arm oder Ihrem Bein, so dass der Motor im Falle eines versehentlichen Überbordgehens stoppt.

WARNING
Read Owner's Manuals and labels.
Wear an approved personal flotation device (PFD).
Attach engine shut-off cord (lanyard) to your PFD, arm, or leg so the engine stops if you accidentally leave the helm, which could prevent a runaway boat.

Service

Safety when performing maintenance tasks

DANGER

Life-threatening danger due to rotating propeller.

The propeller blades have very sharp edges. There is a very high danger of serious cuts from the propeller, which can even result in death.

Ensure that the outboard engine cannot restart when performing maintenance tasks. One way of doing this is to remove the ignition key or the clip on the kill switch lanyard from the stop button.

There is even a risk of injury when the propeller is not rotating. Wear protective gloves.

Maintenance intervals

The table gives recommendations for the maintenance intervals by operating hours and tasks. The page numbers refer to the descriptions of the different tasks.

The maintenance intervals given in the table are valid for when the outboard engine is used under normal conditions.

Ask your authorized dealer for information on suitable maintenance intervals based on the conditions of your particular application.

If the outboard engine is used in more challenging conditions such as more frequent use at full speed or in muddy, silty, sandy, acidic or shallow water, maintenance tasks may need to be carried out more frequently than indicated in the table. If the frequency of the maintenance tasks is not increased under such conditions, damage may occur.

Maintenance interval	Task	Page
After every operation	Emptying the water separator	126
	Emptying the water separator in the fuel feed line	130
	Flushing the cooling circuit	124



Maintenance interval	Task	Page
250 operating hours *	Checking the tightening torques on the exhaust elbow	125
	Replacing the fuel filter element	128
	Replacing the fuel filter element in the fuel feed line	130
	Changing the engine oil	137
	Replacing the oil filter	131
	Changing the transmission oil	140
	Checking and adjusting the cowl lock	155
250 operating hours	Lubricating the transom	135
	Lubricating the shift lever	136
	Clean the fuel tank	**
	Replace the impeller of the water pump	***
	Replace the water pressure sensor	***
	Check the thermostats and cooling ducts	***
	Check the battery	***
	Check electrical connections	***
500 operating hours	Replacing the idle relief cover	133
	Replace the low-pressure fuel lines	***
	Replace the water lines	***
	Replace the compressor hose	***
	Replace the glow plugs	***
	Replace the exhaust manifold	***
	Replace the exhaust cover and water cover	***
	Replace the roller tappet	***
	Replace the high-pressure fuel lines	***
	Check the transoms	***
	Replace the thermostats	***
	1,000 operating hours	Replace the battery

* Additionally, **once** 50 operating hours after initial start-up

** The fuel tank is not part of the scope of delivery. The cleaning of the fuel tank is not described in this owner's manual. More information regarding the cleaning of the fuel tank is given in the documentation supplied with it.

*** These maintenance tasks are described in the workshop handbook and may only be carried out by skilled and trained personnel. Inform your workshop in advance of the work to be carried out.

Flushing the cooling circuit

After each operation of the outboard engine in salt water, brackish water or water polluted with chemicals, the cooling circuit must be flushed thoroughly with fresh water.

On the right-hand side of the outboard engine, there is a flushing connector for a Gardena-type 1/2" hose connection (see page 31).

Alternatively, you can connect a flushing adapter (1) to the cooling water inlet. When flushing in that way, the engine must be idling.

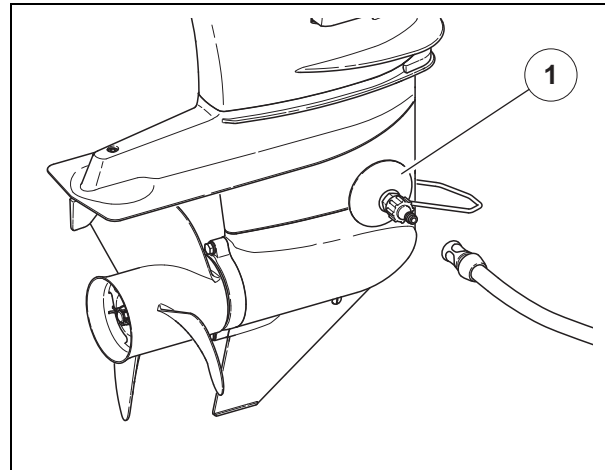

- Attach a hose to the flushing connector (2).
- Alternatively, you can attach a flushing adapter to the cooling water inlet.
- Fully open the freshwater supply and flush for at least 10 minutes.
- When using the flushing adapter, start the engine and leave it idling.
- Before removing the flushing adapter, stop the outboard engine and ensure it cannot restart, by removing the ignition key, for example.

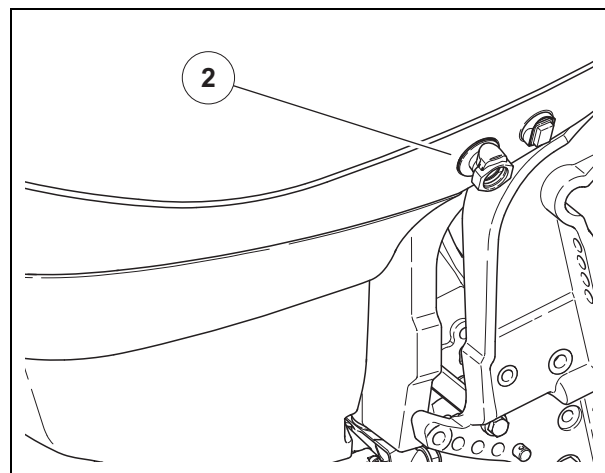

Checking the tightening torques on the exhaust elbow

You must make sure that the bolts on the exhaust elbow are tightened to the specified torque.

- Stop the outboard engine and ensure it cannot restart, by removing the ignition key, for example.
- Remove the cowling (see page 81).
- Tighten the bolts (1) to (8) one by one with a torque wrench (30 Nm).
- Install the cowling (see page 81).

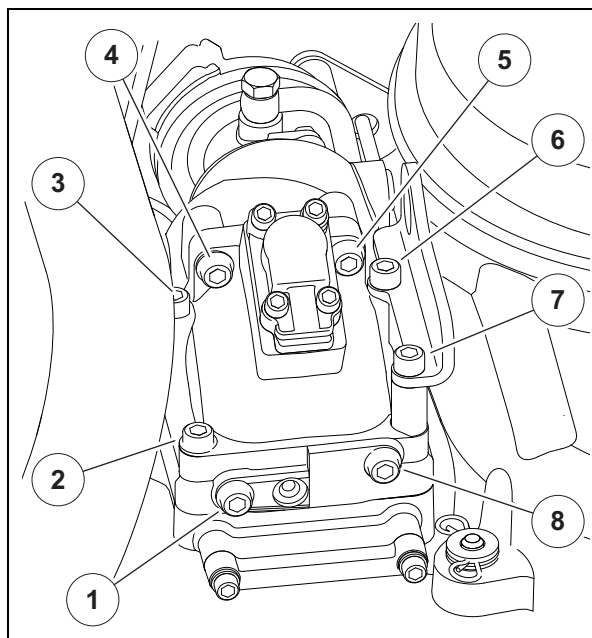

Emptying the water separator



CAUTION

Risk of falling due to slippery surfaces.

Even small amounts of leaked fuel can result in people slipping, falling and sustaining serious injuries.

Whenever working on the engine, ensure that the surrounding area and the ground remain free from fuel leaks. Wipe up any leaked fuel immediately.

NOTICE

Risk of environmental damage.

Ensure that any spilled fuel is wiped up and does not get into the water. Dispose of any fuel in accordance with applicable regulations.

The fuel line under the cowling has a fuel filter with water separator. Any water removed from the fuel is collected in the lower area of the cone.

Empty the water separator regularly, otherwise the water can get back into the fuel, which reduces the performance of the engine and can even damage it.

The fuel filter (1) is located on the right-hand side of the engine.

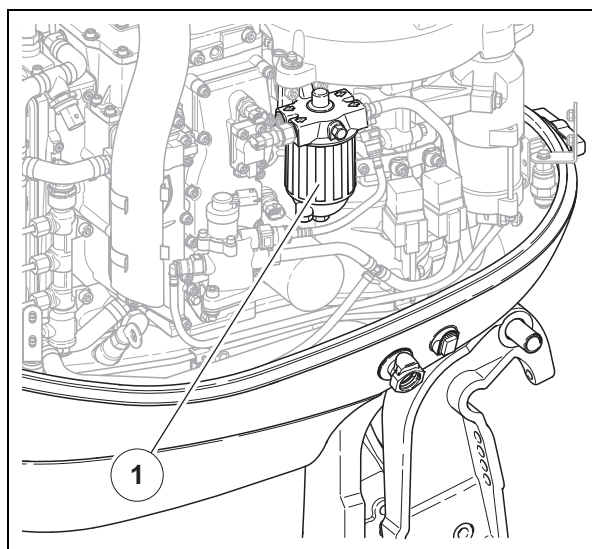

- Stop the outboard engine and ensure it cannot restart, by removing the ignition key, for example.
- Remove the cowling (see page 81).

- Place an absorbent cloth under the fuel filter to catch the water and fuel.
- Loosen the vent plug (1) at the top of the fuel filter using a wrench, and then remove it.
- Using a wrench, loosen the plug (2) on the cone, and then open it briefly to try to drain just the water but no fuel.
- Catch any water and fuel that leaks out using the cloth.
- Close the plug (2) and tighten it using a wrench.
- If a large amount of fuel comes out, you will need to unscrew the cone and fill it with fuel (see page 128).
- Install the vent plug (1) at the top of the fuel filter and tighten it using a wrench.
- Start up the outboard engine (see page 85) to ensure that the plugs are tight and no water or fuel leaks out from the filter.
- Stop the outboard engine.
- Install the cowling (see page 81).

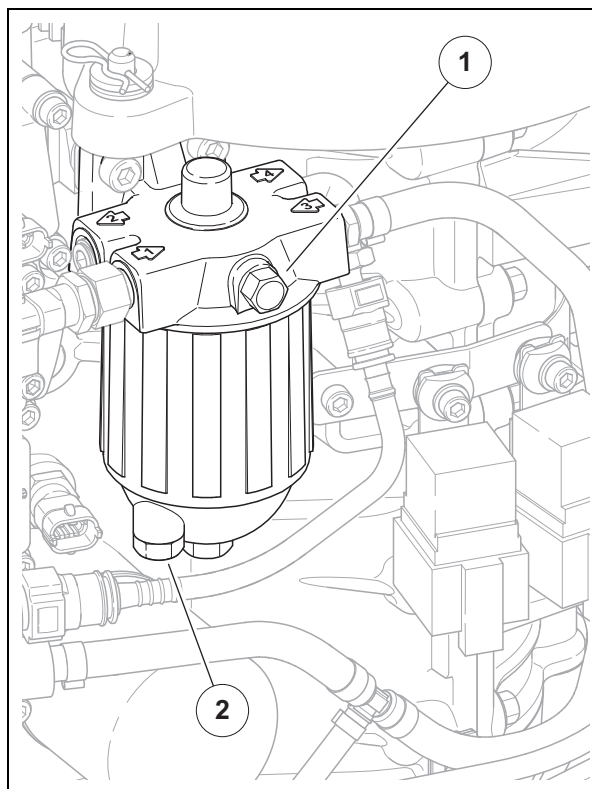

Replacing the fuel filter element



CAUTION

Risk of falling due to slippery surfaces.

Even small amounts of leaked fuel can result in people slipping, falling and sustaining serious injuries.

Whenever working on the engine, ensure that the surrounding area and the ground remain free from fuel leaks. Wipe up any leaked fuel immediately.

NOTICE

Risk of environmental damage.

Ensure that any spilled fuel is wiped up and does not get into the water. Dispose of any fuel and the filter element in accordance with applicable regulations.

The fuel line under the cowling has a fuel filter with water separator.

The fuel filter element must be replaced frequently, otherwise impure fuel can affect the performance of the engine or even damage it.

The fuel filter (1) is located on the right-hand side of the engine.

Use only the following type of replacement fuel filter element:

Parker | Racor R11S (2 µm)

Only use new sealing rings.

- Stop the outboard engine and ensure it cannot restart, by removing the ignition key, for example.
- Remove the cowling (see page 81).

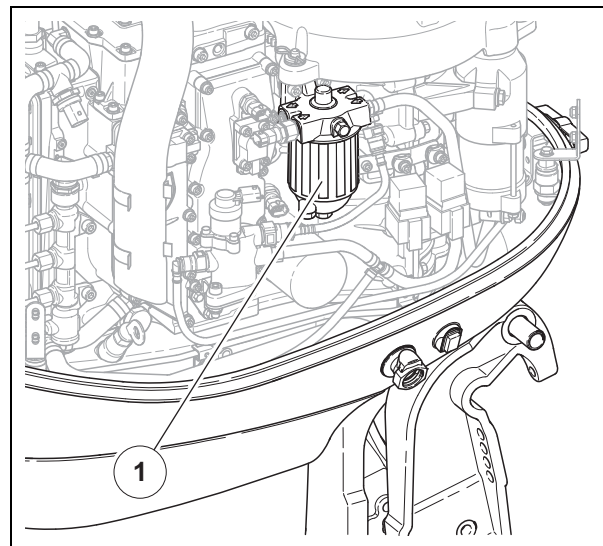

- Place an absorbent cloth and suitable receptacle for catching fuel under the fuel filter.
- Loosen the vent plug (1) at the top of the fuel filter using a wrench, and then remove it.
- Using a wrench, completely unscrew the plug (4) on the cone.
- Catch any fuel which leaks out in the receptacle and with the cloth.
- Install and tighten the plug (4) using a wrench.
- Apply a wrench to the hexagon point (3) at the bottom, loosen the cone (2) of the fuel filter, and then remove it by hand.

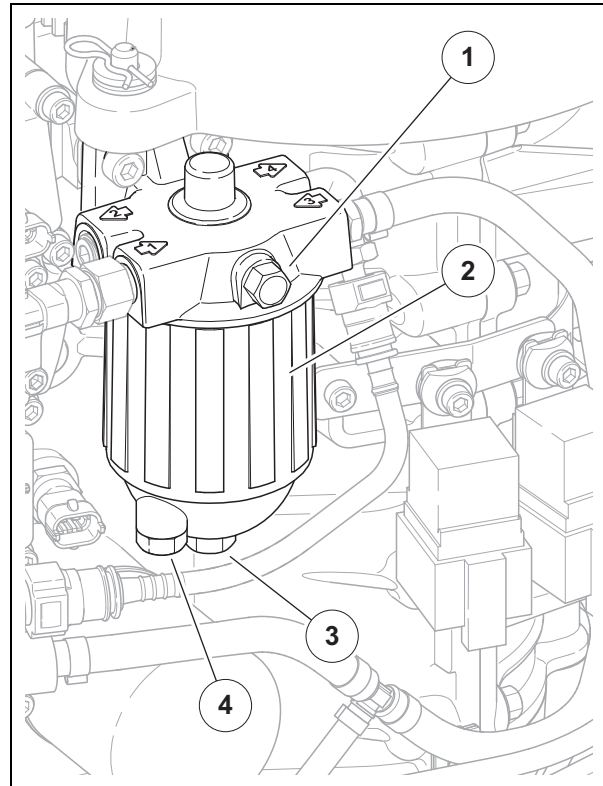

- Remove the fuel filter element (6) and the two sealing rings from the cone and dispose of them in accordance with applicable regulations.
- Lubricate the new O-ring (7) with a little engine oil and place it in the groove on the bottom of the new fuel filter element.
- Lubricate the new flat sealing ring (5) with a little engine oil and place it on the top of the fuel filter element.
- Place the fuel filter element (6) into the cone (2) and ensure it fits correctly.
- Fill the cone (2) with fuel, align it carefully under the top of the fuel filter and tighten it.
- Tighten the cone (2) firmly by hand.
- Install the vent plug (1) at the top of the fuel filter and tighten it using a wrench.
- Start-up the outboard engine (see page 85) and check that the fuel filter is tight and no fuel or water comes out of it.
- Stop the outboard engine.
- Install the cowling (see page 81).

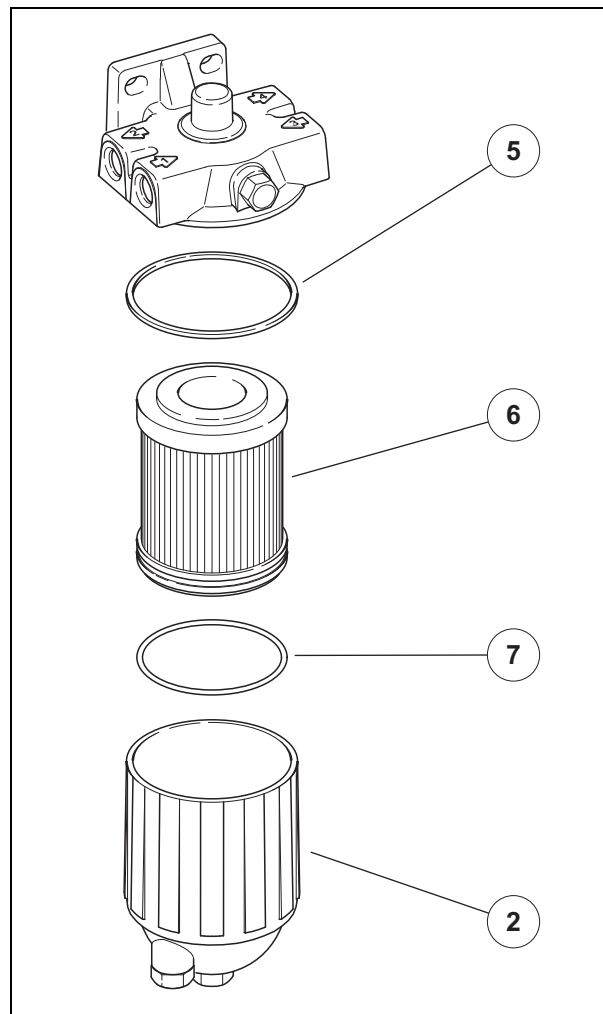

Emptying the water separator in the fuel feed line

A fuel filter with water separator must be installed in the fuel feed line between the tank and the outboard engine (see page 61).

Empty the water separator regularly, otherwise the water can get back into the fuel, which reduces the performance of the engine and can even damage it.

The fuel filter with water separator in the fuel feed line between the tank and the outboard engine is not included in the scope of delivery of the outboard engine. Find out more about emptying the water separator in the documentation supplied with the fuel filter.

Replacing the fuel filter element in the fuel feed line

A fuel filter with water separator must be installed in the fuel feed line between the tank and the outboard engine (see page 61).

The fuel filter element must be replaced frequently, otherwise impure fuel can affect the performance of the engine or even damage it.

The fuel filter with water separator in the fuel feed line between the tank and the outboard engine is not included in the scope of delivery of the outboard engine. Find out more about replacing the fuel filter element in the documentation supplied with the fuel filter.

Cleaning the fuel tank

The inside of the fuel tank must be cleaned regularly, otherwise impure fuel can affect the performance of the engine and even damage it.

The fuel tank is not supplied as standard with the outboard engine. Find out more about the recommended cleaning procedure in the documentation supplied with the fuel tank.

Replacing the oil filter



CAUTION

Risk of falling due to slippery surfaces.

Even small amounts of oil can result in people slipping, falling and sustaining serious injuries.

Whenever working on the engine, ensure that the surrounding area and the ground remain free from oil. Wipe up any leaked oil immediately.

NOTICE

Risk of environmental damage.

Ensure that any spilled engine oil is wiped up and does not get into the water. Dispose of engine oil and the oil filter in accordance with applicable regulations.

The filter (1) for the engine oil can be found under the cowling on the right-hand side. The oil filter must be replaced frequently, otherwise impure engine oil can affect the performance of the engine or even damage it.

The following type of oil filter must be used at all times:

Bosch F 026 407 001

- Stop the outboard engine and ensure it cannot restart, by removing the ignition key, for example.
- Remove the cowling (see page 81).

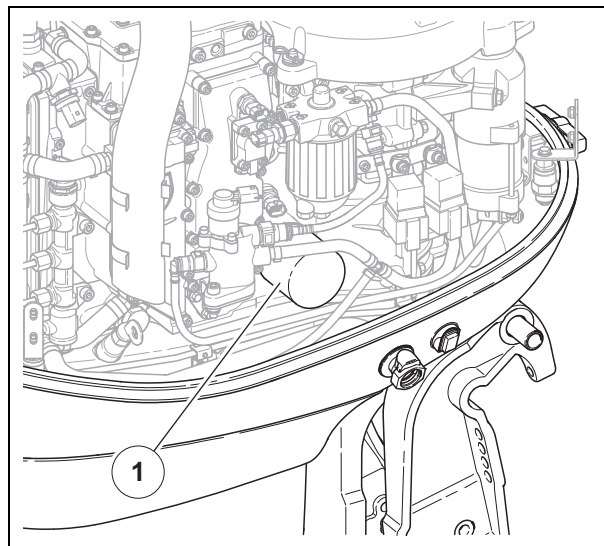

- Place an absorbent cloth and suitable receptacle for catching engine oil under the oil filter.
- Using an oil filter wrench, completely unscrew the oil filter.
- Catch any of the remaining engine oil from the filter in a receptacle and dispose of it in accordance with applicable regulations.
- Apply a little engine oil on the seal of the new oil filter.
- Place the new oil filter carefully and screw it in by hand.
- Clean any surfaces soiled with engine oil immediately and thoroughly.
- Tighten the oil filter using an oil filter wrench (11 Nm).
- Start up the outboard engine (see page 85) and check that the oil filter is screwed in tightly and no engine oil leaks out.
- Stop the outboard engine.
- Install the cowling (see page 81).

Replacing the idle relief cover

Exhaust gas particles collect on the inside of the idle relief cover. Over time, these particles clog the passages and start to impair the function of the idle relief system. As the effort required for a thorough cleaning is very high, one option is to simply replace the cover and seal.

Only use original spare parts (cover and seal).

Some of the cover bolts (1) are located behind the casing (2), below the cowling. For that reason, you will first need to remove the casing.

- Stop the outboard engine and ensure it cannot restart, by removing the ignition key, for example.
- Remove the cowling (see page 81).
- Completely remove the bolt (3) and washer on the left- and right-hand sides.
- Hold the casing (2).
- Completely remove the bolt (4) and washer on the left- and right-hand sides of the underside at the back of the lower cowling.
- Remove the casing.

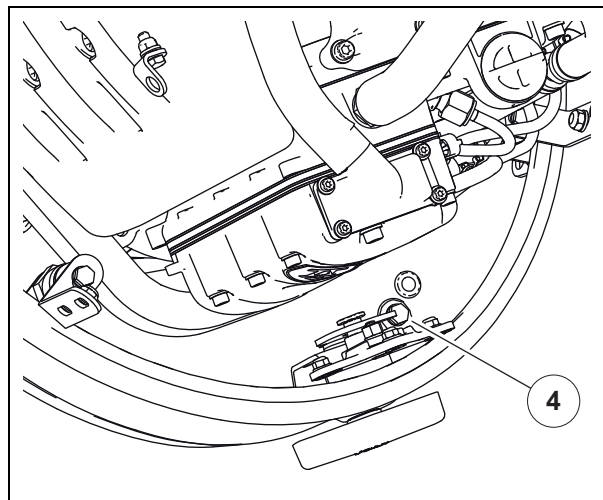
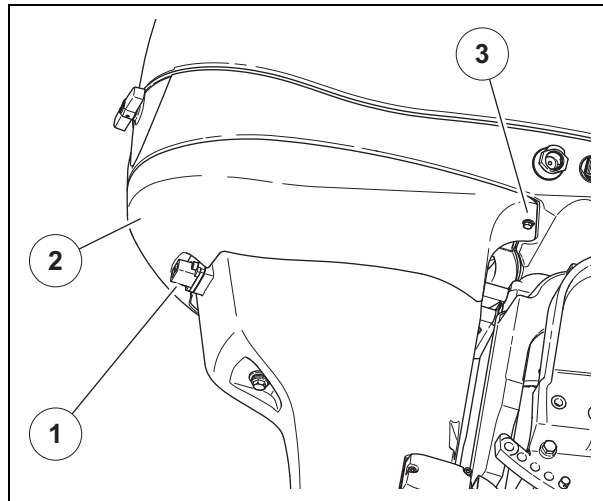

- Completely remove the four bolts and washers of the cover (1).
- Remove the cover and seal, and dispose of them in accordance with applicable regulations.
- Clean the contact surface, and then position the new cover and seal.
- Install and tighten the four bolts and washers.

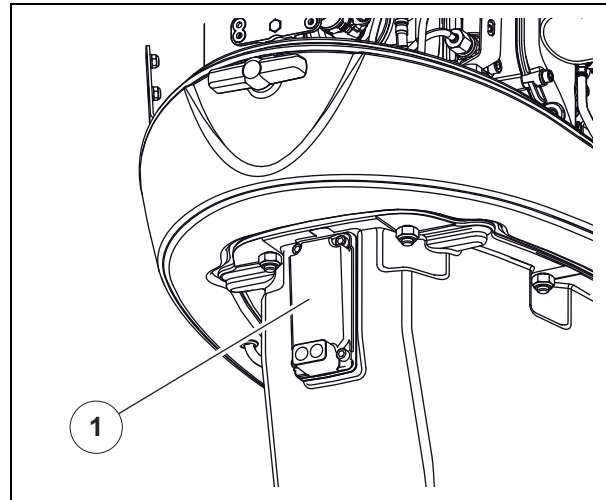

- Position the casing from the underneath and hold it.
- Install and tighten the bolt (2) and washer on the left- and right-hand sides.

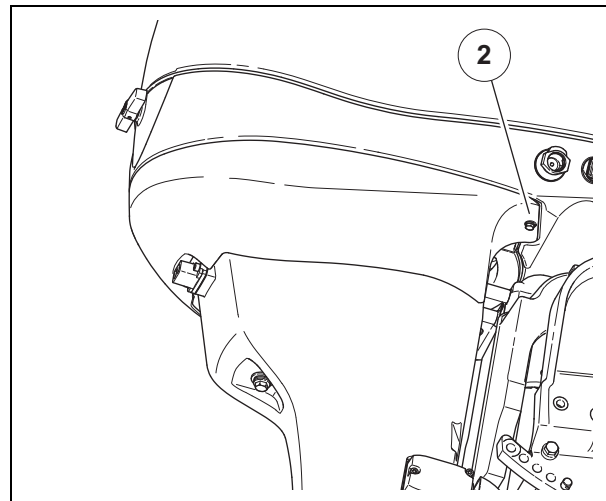

- From the top, install and tighten the two bolts (3) and washers on the underside at the back of the lower cowling.
- Check that the casing is firmly fixed in place.
- Install the cowling (see page 81).

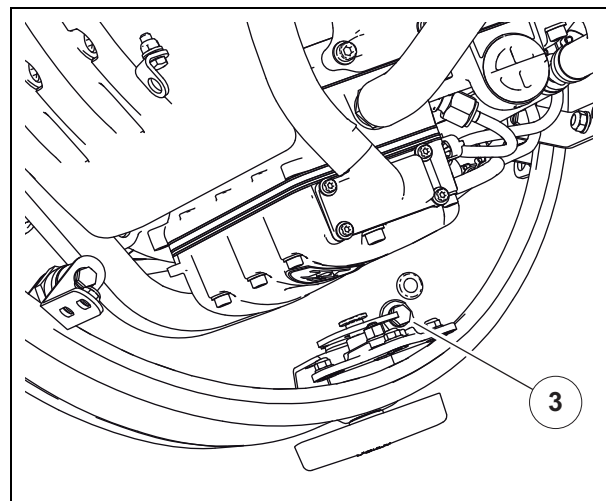

Lubrication



CAUTION

Risk of falling due to slippery surfaces.

Even small amounts of lubricant can result in people slipping, falling and sustaining serious injuries.

Whenever working on the engine, ensure that the surrounding area and the ground remain free from lubricant. Wipe up any leaked grease immediately.

Lubricating the transom

The joints on the transoms need to be lubricated regularly so that they continue to move freely and easily, and to stop the power trim and the steering mechanism from becoming overloaded.

- Using a grease gun, lubricate the lubricating nipples on the right (1) and left (2) of the tilting pin (see *Permitted fuels/lubricants*, page 173).
- Using the power trim, tilt the outboard engine up and down as far as it will go several times in order to distribute the grease.
- Remove any excess grease with an absorbent cloth.

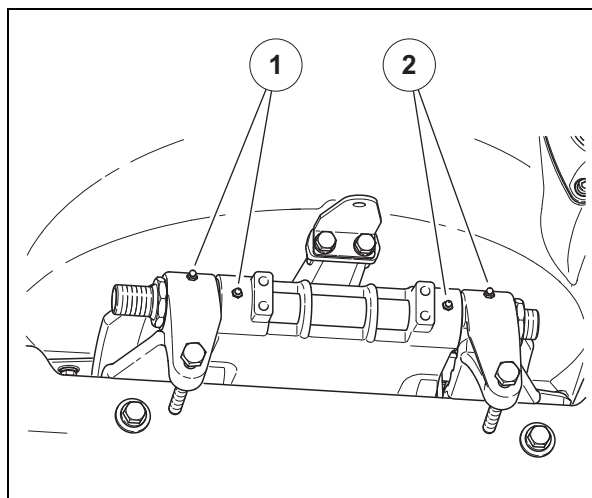

Lubricating the shift lever

The knuckle eyes on the shift lever pins must be greased regularly so that they continue to move freely and easily and so the control cables do not become overloaded.

- Using a brush, grease the pins of the upper (1) and lower (2) levers (see *Permitted fuels/lubricants*, page 173).
- Remove any grease from other surfaces using an absorbent cloth.

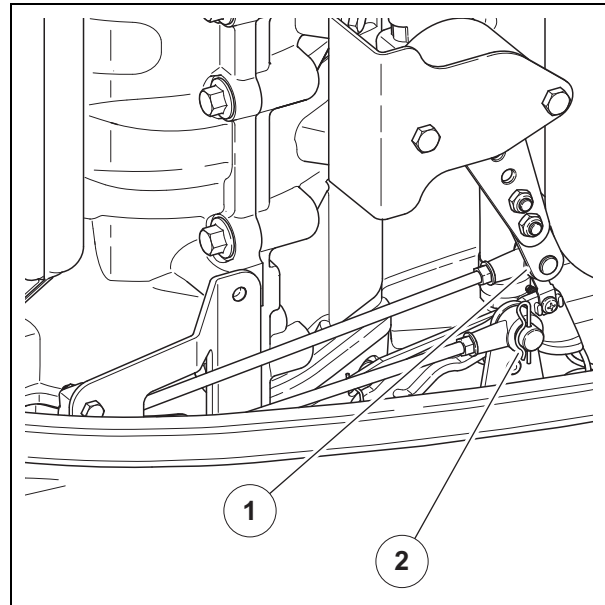

Lubricating the propeller shaft

The propeller shaft must be greased before the propeller is mounted (see page 147).

- Grease the propeller shaft (3) lightly with suitable lubricant (see *Permitted fuels/lubricants*, page 173).
- Remove any grease from other surfaces using an absorbent cloth.

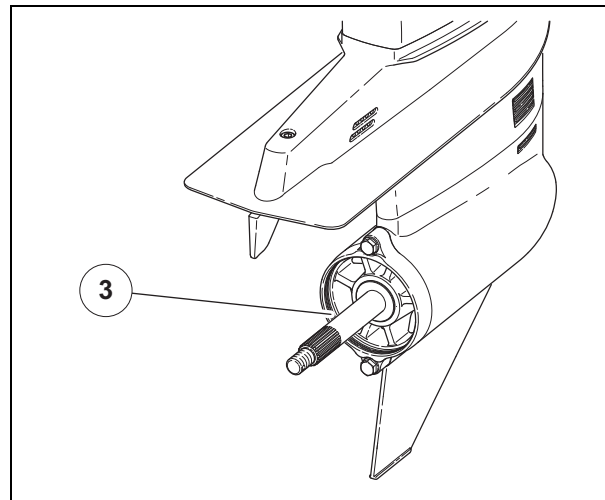

Changing the engine oil

NOTICE

Danger of damage to engine.

Under no circumstances must synthetic and mineral oils be mixed. Only use the approved engine oils (see *Permitted fuels/lubricants*, page 173).

Draining engine oil



CAUTION

Risk of falling due to slippery surfaces.

Even small amounts of oil can result in people slipping, falling and sustaining serious injuries.

Whenever working on the engine, ensure that the surrounding area and the ground remain free from oil. Wipe up any oil spills immediately.

NOTICE

Risk of environmental damage.

Ensure that any spilled oil is wiped up and does not get into the water. Dispose of any oil in accordance with current regulations.

When draining off the engine oil, you will need a receptacle which can hold at least 8 liters.

To drain the engine oil, the outboard engine must be vertical (lowest tilting position) and lifted out of the water.

- Stop the outboard engine and ensure it cannot restart, by removing the ignition key, for example.
- Place a large collecting basin with a minimum capacity of at least 8 liters under the oil drain plug (1).
- Remove the oil drain plug completely and let the engine oil drain out.
- Dispose of the sealing ring around the oil drain plug in accordance with applicable regulations.
- Once the engine oil stops flowing constantly, leave at least 10 minutes for the remaining oil to drain out.
- Once the engine oil has completely stopped dripping out, place a new sealing ring around the oil drain plug (1) and tighten it (30 Nm).
- Clean any surfaces soiled with engine oil immediately and thoroughly.
- Replace the oil filter (see page 131).

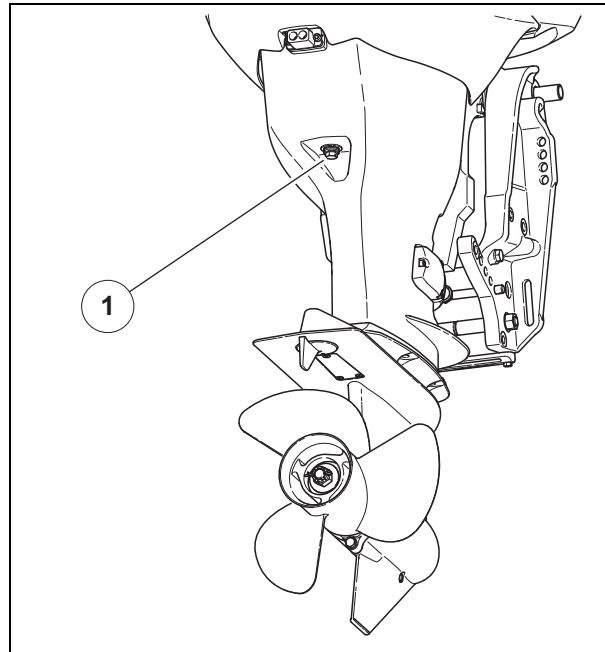

Refilling engine oil



CAUTION

Risk of falling due to slippery surfaces.

Even small amounts of oil can result in people slipping, falling and sustaining serious injuries.

Whenever working on the engine, ensure that the surrounding area and the ground remain free from oil. Wipe up any oil discharge or spillage immediately.

NOTICE

Risk of environmental damage.

Ensure that any spilled oil is wiped up and does not get into the water. Dispose of any oil in accordance with current regulations.

- Whenever you change the oil, replace the oil filter before pouring in the new oil (see page 131).
- Stop the outboard engine and ensure it cannot restart, by removing the ignition key, for example.
- Remove the cowling (see page 81).
- Have an absorbent, clean cloth ready.
- On the back of the engine, remove the plug on the filling hole and store it in a clean place.
- Carefully refill fresh engine oil. The maximum capacity is 6.5 liters.
- Install the plug and tighten it by hand.
- Clean any surfaces soiled with engine oil immediately and thoroughly.
- Check the oil fill level (see page 118).

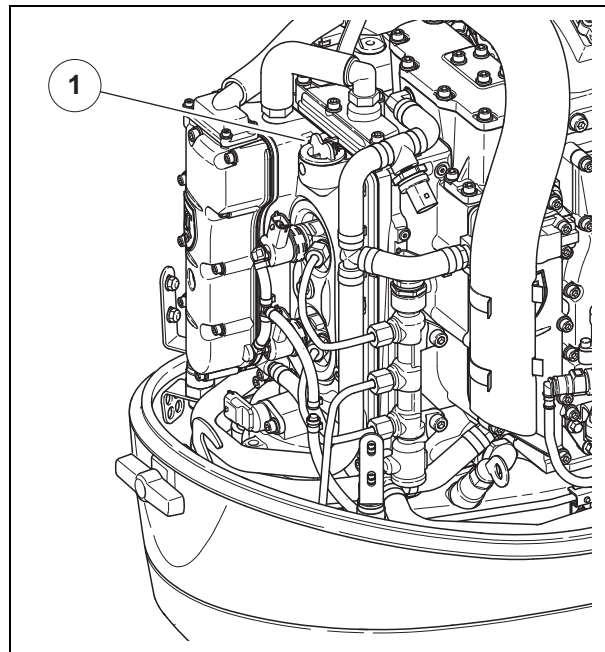

Changing the transmission oil

NOTICE

Danger of damage to engine.

Under no circumstances must synthetic and mineral oils be mixed. Only use approved transmission oils (see *Permitted fuels/lubricants*, page 173).

Draining the transmission oil



CAUTION

Risk of falling due to slippery surfaces.

Even small amounts of oil can result in people slipping, falling and sustaining serious injuries.

Whenever working on the engine, ensure that the surrounding area and the ground remain free from oil. Wipe up any oil spills immediately.

NOTICE

Risk of environmental damage.

Ensure that any spilled oil is wiped up and does not get into the water. Dispose of any oil in accordance with current regulations.

When draining off the transmission oil, you will need a receptacle which can hold at least 1 liter.

To drain the transmission oil, the outboard engine must be vertical (lowest tilting position) and lifted out of the water.

- Stop the outboard engine and ensure it cannot restart, by removing the ignition key, for example.
- Place a collecting basin with a minimum capacity of 1 liter under the drain hole (2) for the transmission oil.
- Have an absorbent, clean cloth ready.
- Completely unscrew the plug (1) on the ventilation hole.
- Completely unscrew the plug (2) on the drain hole and drain off the transmission oil.
- Dispose of the seals around the plugs in accordance with applicable regulations.
- Refilling transmission oil (see page 141).

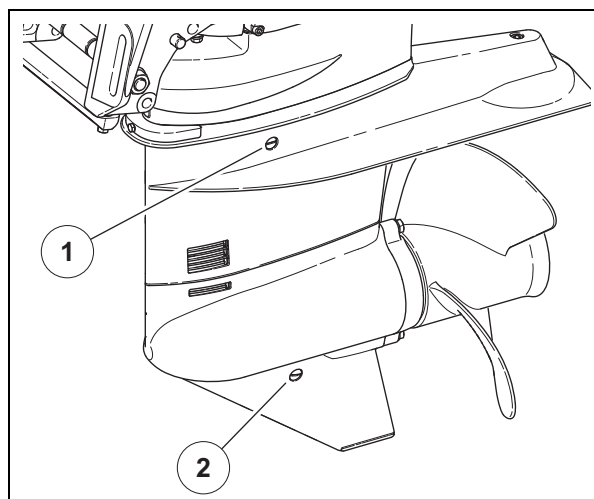

Refilling transmission oil



CAUTION

Risk of falling due to slippery surfaces.

Even small amounts of oil can result in people slipping, falling and sustaining serious injuries.

Whenever working on the engine, ensure that the surrounding area and the ground remain free from oil. Wipe up any oil discharge or spillage immediately.

NOTICE

Risk of environmental damage.

Ensure that any spilled oil is wiped up and does not get into the water. Dispose of any oil in accordance with current regulations.

To refill the transmission oil, the outboard engine must be vertical (lowest tilting position) and lifted out of the water. Both plugs must be removed (see page 140).

- Have an absorbent, clean cloth ready.
- Push the tip of the oil tube into the drain hole (2).
- Squeeze the new transmission oil out into the engine. The maximum capacity is 0.5 liters.
- The maximum level has been reached when the transmission oil starts to come out of the ventilation hole (1).
- Replace the seals around both plugs and tighten the plugs.
- Clean any surfaces soiled with transmission oil immediately.

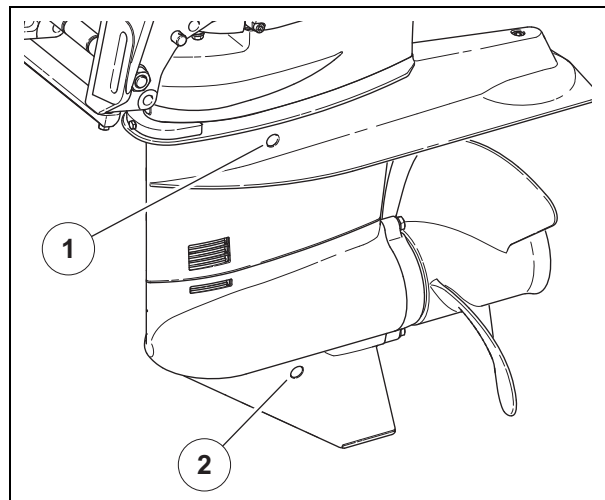

Refilling hydraulic oil



CAUTION

Risk of falling due to slippery surfaces.

Even small amounts of oil can result in people slipping, falling and sustaining serious injuries.

Whenever working on the engine, ensure that the surrounding area and the ground remain free from oil. Wipe up any oil spills immediately.

NOTICE

Danger of damage to the power trim.

Only use approved hydraulic oils (see *Permitted fuels/lubricants*, page 173).

NOTICE

Risk of environmental damage.

Ensure that any spilled oil is wiped up and does not get into the water. Dispose of any oil in accordance with current regulations.

If the performance of the power trim drops, one of the causes might be a lack of hydraulic oil.

When refilling the hydraulic oil, the outboard engine must be removed from the water.

- Tilt the outboard engine up using the power trim (see page 101).
- Once the outboard engine is tilted up completely, move the safety catch down (see page 101).
- Carefully unscrew the plug(1) on the filling hole for the hydraulic oil, remove it and store it in a clean place.
- Dispose of the sealing ring in accordance with applicable regulations.
- Place the tip of the oil tube into the filling hole.
- Squeeze the new hydraulic oil out of the tube.

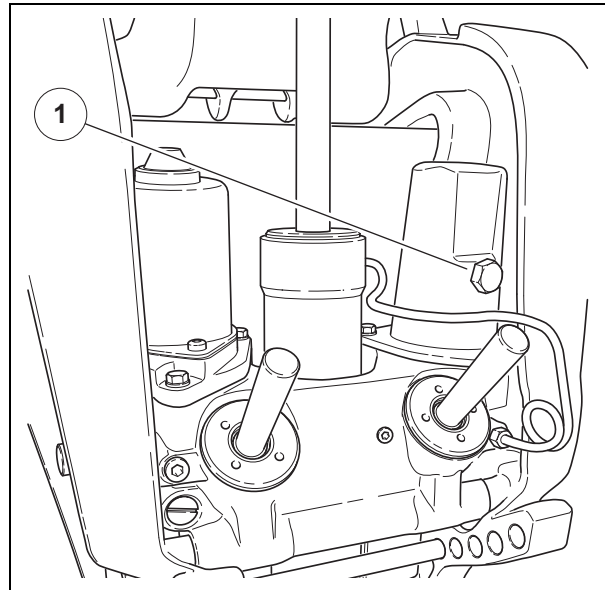

- Move the safety catch up (see page 101).
- Using the power trim, tilt the outboard engine down completely, and then return it to the highest position in order to remove any air bubbles from the hydraulic oil.
- Once the outboard engine is tilted up completely, move the safety catch down (see page 101).
- Place the tip of the oil tube into the filling hole once more.
- Carefully squeeze a little more hydraulic oil into the hole until it reaches the lower edge of the filling hole (2).
- Replace the sealing ring around the plug and tighten the plug.
- Clean any surfaces soiled with hydraulic oil immediately.
- Move the safety catch up (see page 101).

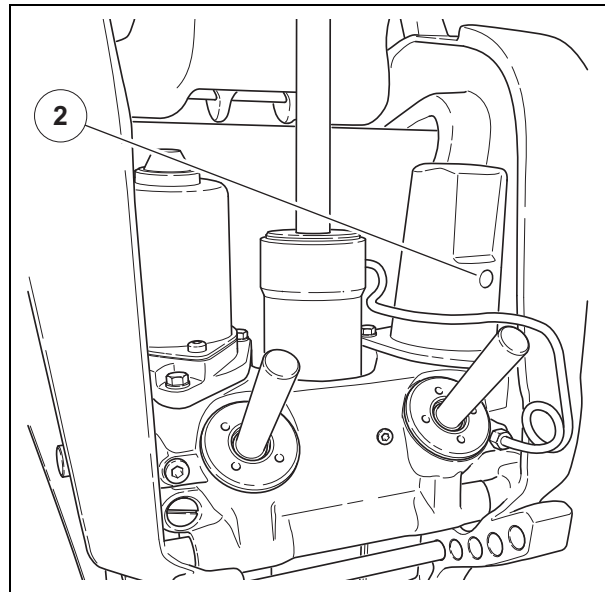

Repairs

Safety when carrying out repairs



DANGER

Life-threatening danger due to rotating propeller.

The propeller blades have very sharp edges. There is a very high danger of serious cuts from the propeller, which can even result in death.

Ensure that the outboard engine cannot restart when carrying out repairs. One way of doing this is to remove the ignition key or the clip on the kill switch lanyard from the stop button.

There is even a risk of injury when the propeller is not rotating. Wear protective gloves.

Repairing the propeller

NOTICE

Risk of damage to bearings.

Improperly repaired propellers can result in serious damage to the bearings on the outboard engine due to imbalance or vibration.

Never repair a damaged propeller (e.g., by bending, welding or grinding). Always replace a damaged propeller with a new approved propeller (see *Approved propellers*, page 178).

Replacing the propeller

Selecting a propeller



WARNING

Danger of reduced maneuverability due to incorrect propeller.

Only install approved propellers (see *Approved propellers*, page 178).

In order to ensure safety and optimum performance, the propeller must be selected according to the type of boat and cargo.

The size and design of the propeller has a considerable influence on the speed, acceleration and maneuverability of the boat, as well as the useful life and the fuel consumption of the engine.

Selecting an unsuitable propeller can result in serious damage to the engine and can therefore affect the safety of the boat.

If, in an emergency or an exceptional situation, none of the approved propellers are available and a propeller still needs to be installed, you must take into account the following conditions:

- The propeller must fit exactly into the profile of the propeller hub or must be installed with a suitable adapter kit. No physical adjustments must be made.
- When installed, there must be a minimum distance (1) of 50 mm between the propeller blades and the trab trim.
- The propeller selected must ensure that the speed of the engine with a fully open throttle valve lies within the permitted range (see *Technical data* from page 171 onwards).

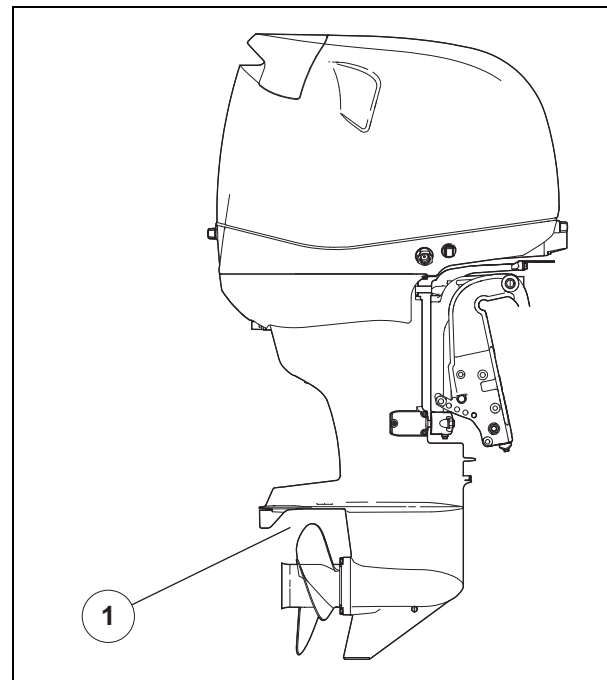

Removing the propeller



DANGER

Life-threatening danger due to rotating propeller.

The propeller blades have very sharp edges. There is a very high danger of serious cuts from the propeller, which can even result in death.

Ensure that the outboard engine cannot restart when working on the propeller. One way of doing this is to remove the ignition key or the clip on the kill switch lanyard from the stop button.

There is even a risk of injury when the propeller is not rotating. Wear protective gloves.

For removal, the propeller must be out of the water.

The outboard engine must be stopped and prevented from starting up again (e.g., by removing the ignition key).

- Wedge a strip of wood (1) between the anti-cavitation plate and the blades in order to stop the propeller from moving.
- Bend open the cotter pin (2), remove it from the hole and dispose of it. **Attention!** Do not reuse the cotter pin.
- Loosen, remove, clean and store the castellated nut (3) in a clean place.
- Remove, clean and store the washer from the propeller shaft in a clean place.
- Remove the propeller from the shaft by hand.

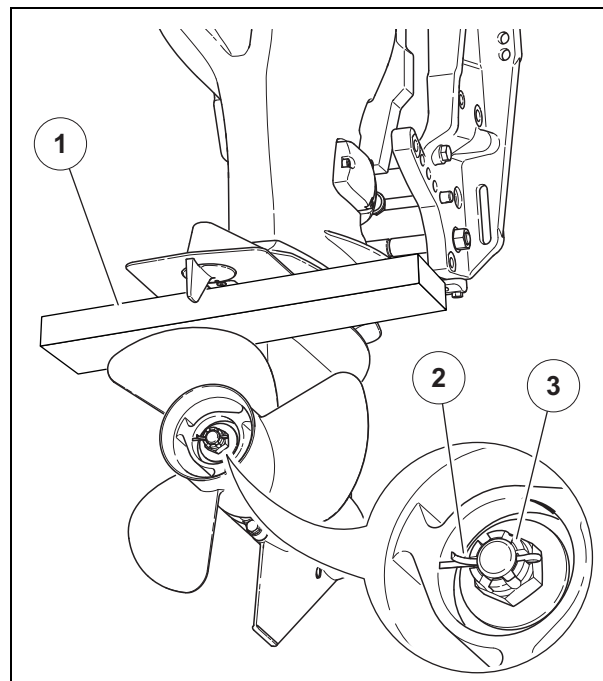

- If equipped, remove the adapter kit from the propeller.
- If the components of the adapter kit are to be reused, check them carefully for damage.
Attention! Do not reuse damaged parts.
- Remove the pressure disk (2) from the propeller shaft (1), clean it, and then store it in a clean place.
- Clean the propeller shaft thoroughly and check for damage. **Attention!** If there is any visible damage to the propeller shaft or hub, the propeller shaft must be replaced (see workshop handbook).

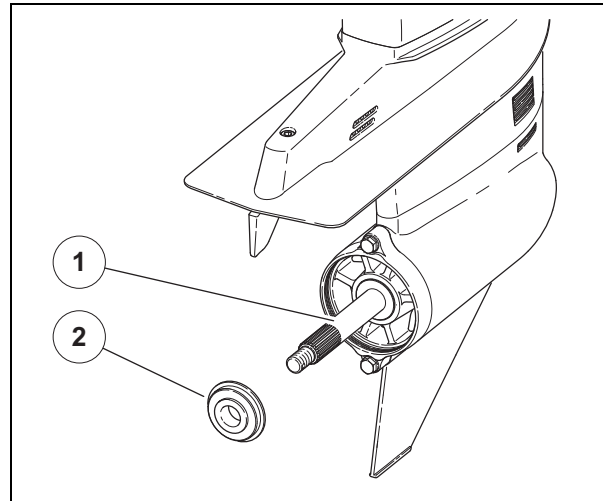

Installing the propeller



DANGER

Life-threatening danger due to rotating propeller.

The propeller blades have very sharp edges. There is a very high danger of serious cuts from the propeller, which can even result in death.

Ensure that the outboard engine cannot restart when working on the propeller. One way of doing this is to remove the ignition key or the clip on the kill switch lanyard from the stop button.

There is even a risk of injury when the propeller is not rotating. Wear protective gloves.

The propeller must be installed out of the water.

The outboard engine must be stopped and prevented from starting up again (e.g., by removing the ignition key).

The specific instructions for installing the propeller depend on the propeller and adapter kit to be used. Carefully read and observe the information and instructions given for the propeller and adapter kit. The following instructions are only meant to be a rough guide.

- Clean the propeller shaft thoroughly and check for damage.
- Once you have ensured that there is no visible damage, lubricate the propeller shaft with a suitable grease (see *Permitted fuels/lubricants*, page 173).
- Place the pressure disk (1) with the larger diameter first onto the propeller shaft and move it up the tapered end of the shaft as far as it will go.
- Push the plastic coupling (2) from the adapter kit into the back of the propeller as far as it will go.
- Push the drive adapter (3) from the adapter kit into the front of the propeller and the installed plastic coupling as far as it will go. While doing so, rotate the parts slightly so that they engage.
- Place the propeller and the adapter parts onto the propeller shaft and gently rotate until it stops against the pressure disk on the propeller hub.
- Place the washer (4) on the propeller shaft and install the castellated nut (5).
- Wedge a strip of wood (6) between the anti-cavitation plate and the blades in order to stop the propeller from moving and tighten the castellated nut (35 Nm).
- Align the castellated nut (5) with the hole in the propeller shaft and push a new cotter pin (7) through the hole.
- Check that the propeller is firmly installed, and then bend both ends of the split pin.
- Remove the strip of wood and check the propeller can spin freely. The propeller should turn easily and not grind.
- Inspect the propeller regularly (see *Inspection intervals*, page 115).

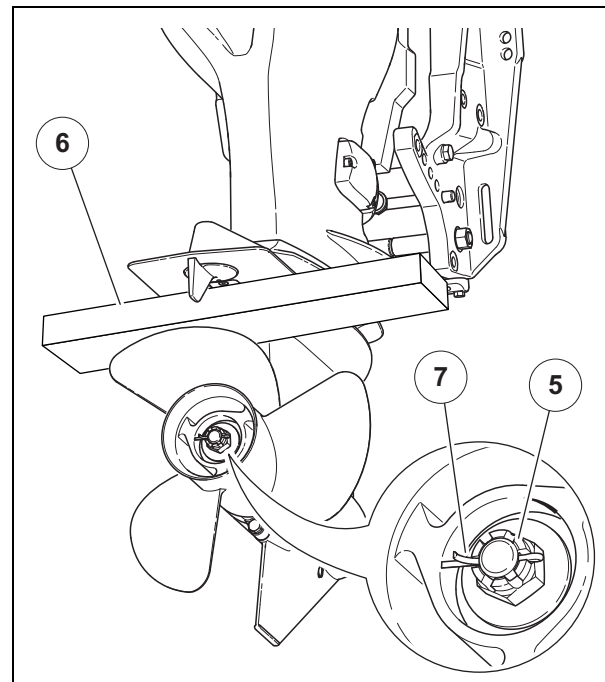
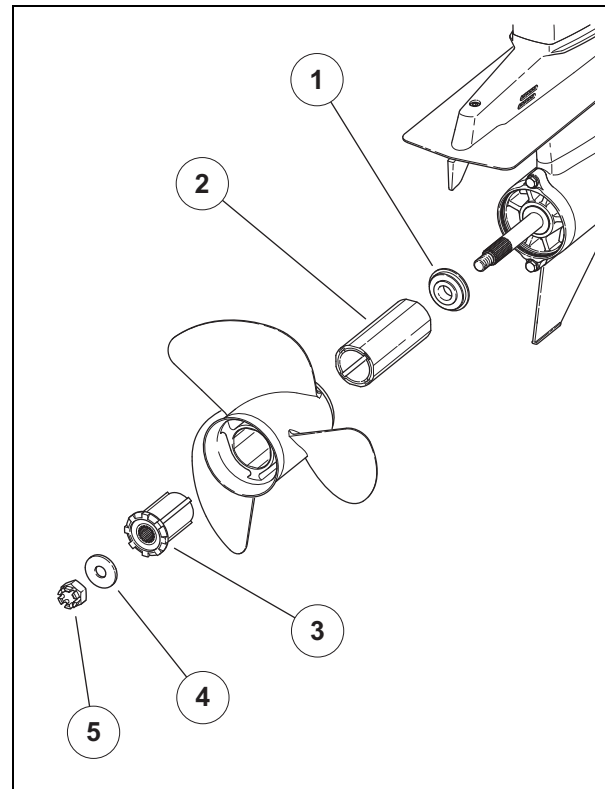

Replacing the sacrificial anodes



DANGER

Life-threatening danger due to rotating propeller.

The propeller blades have very sharp edges. There is a very high danger of serious cuts from the propeller, which can even result in death.

Ensure that the outboard engine cannot restart when working on the propeller. One way of doing this is to remove the ignition key or the clip on the kill switch lanyard from the stop button.

There is even a risk of injury when the propeller is not rotating. Wear protective gloves.

Replace the sacrificial anode once it has been worn down by more than 1/3 of its original size.

Always replace a corroded sacrificial anode with a similar new anode. Do not interchange the sacrificial anodes.

- Tilt the outboard engine up using the power trim until it is completely out of the water (see page 101).
- Prevent the outboard engine from restarting, by removing the ignition key, for example.
- Replace the corresponding sacrificial anode as follows:

Replacing the trab trim

The trab trim must be replaced if it becomes cracked, deformed or damaged in any other way.

Always replace a trab trim with a new trab trim of the same type. Do not use trab trims from other outboard engines.

- Determine and write down the current angle of the trab trim (see page 73).
- Hold the trab trim (2) in place and unscrew the hexagon socket screw (1) on the upper side of the anti-cavitation plate.
- Pull the trab trim down.
- Install the new trab trim and set it at the correct angle.
- Screw the hexagon socket screw from above into the trab trim and tighten it.
- Dispose of the worn or damaged trab trim in accordance with applicable regulations.

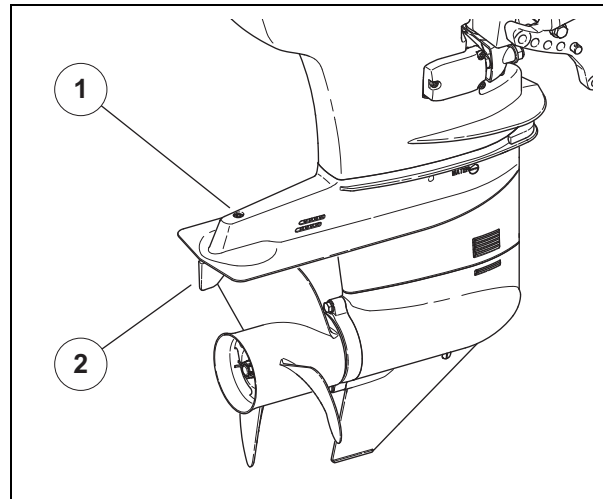

Replacing the sacrificial anode on the transom

Always replace a corroded sacrificial anode with a similar new anode.

- Hold the sacrificial anode (3) in place and remove both bolts.
- Remove the sacrificial anode from the transom.
- Place the bolts into the new sacrificial anode and screw the anode to the underneath of the transom.
- Dispose of the worn sacrificial anode in accordance with applicable regulations.

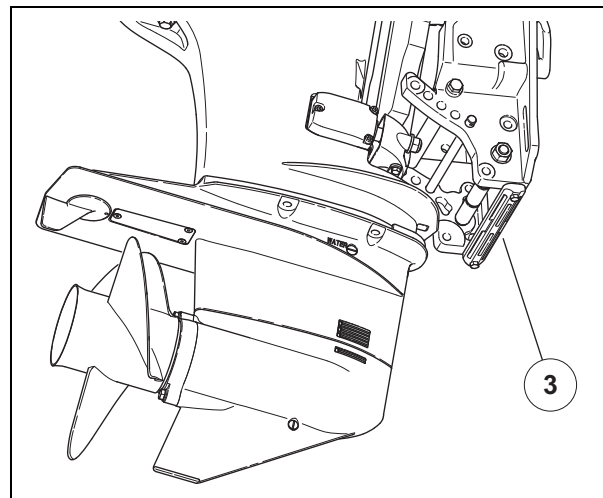

Replacing the sacrificial anode under the vibration damper

Always replace a corroded sacrificial anode with a similar new anode.

- Hold the sacrificial anode in place and remove both bolts (1).
- Remove the sacrificial anode.
- Place the bolts into the new sacrificial anode and screw the anode into place from below.
- Dispose of the worn sacrificial anode in accordance with applicable regulations.

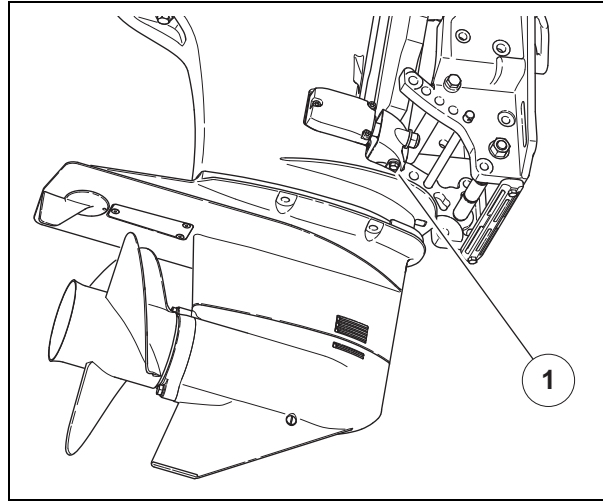

Replacing the sacrificial anode on the shaft

Always replace a corroded sacrificial anode with a similar new anode.

- Hold the sacrificial anode in place and remove the bolt (2).
- Remove the sacrificial anode from the shaft.
- Place the bolt into the new sacrificial anode and screw the anode to the shaft.
- Dispose of the worn sacrificial anode in accordance with applicable regulations.

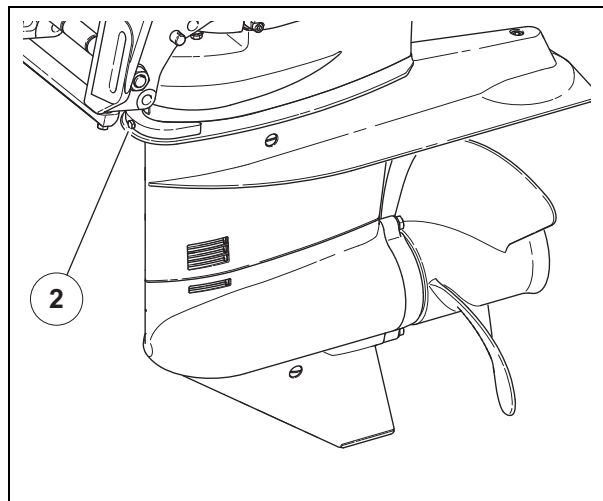

Replacing a fuse

NOTICE

Danger of damage due to incorrect fuse.

Replacing a damaged fuse with a fuse of a different amperage or with another object such as aluminum foil or wire can lead to serious damage to the electrical and electronic components.

Always replace a damaged fuse with a new fuse of the same type and amperage.

The fuses can be found in the fuse box on the front side of the outboard engine, under the cowl.

For the positions and functions of the different fuses, see page 177.

- Stop the outboard engine and ensure it cannot restart, by removing the ignition key, for example.
- Remove the cowling (see page 81).
- Release the fuse box cover (1) and remove it carefully.
- Remove the damaged fuse from the holder and replace it with a new one of the same type.
- Align the fuse box cover and push it in until it locks in place.
- Install the cowling (see page 81).

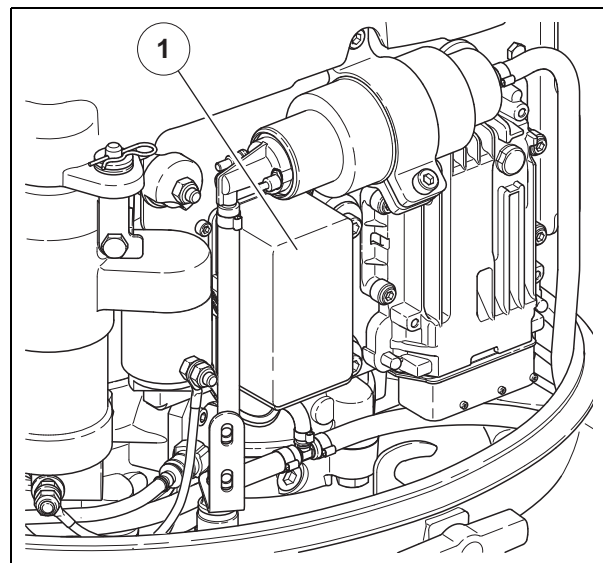

Replacing a relay

NOTICE

Danger of damage due to incorrect relay.

Replacing a damaged relay with a relay with different specifications can result in serious damage or loss of functionality.

Always replace a damaged relay with a relay of the same type.

The relays can be found in the fuse box on the front side of the outboard engine, under the hood.

For the positions and functions of the different relays, see page 177. Use only new relays of the following type:

Omron G8V-RH-1A7T-R-DC12

For instructions on how to replace the power trim relays, see page 154.

- Stop the outboard engine and ensure it cannot restart, by removing the ignition key, for example.
- Remove the cowling (see page 81).
- Release the fuse box cover (1) and remove it carefully.
- Remove the damaged relay from the holder and replace it with a new relay of the same type.
- Align the fuse box cover and push it in until it locks in place.
- Install the cowling (see page 81).

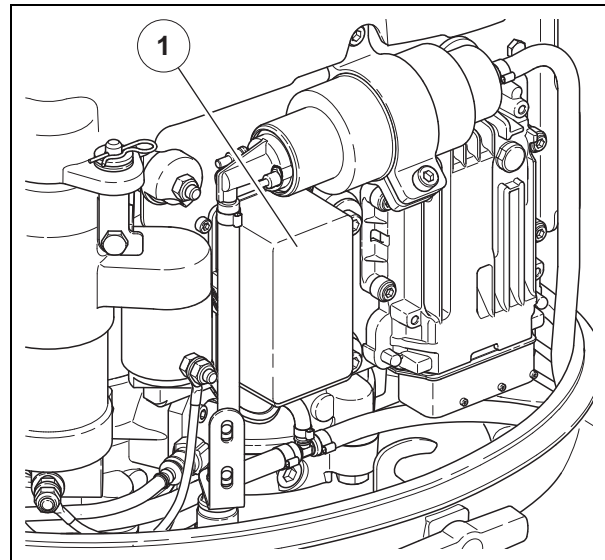

Replacing a power trim relay

NOTICE

Danger of damage due to incorrect relay.

Replacing a damaged relay with a relay with different specifications can result in serious damage or loss of functionality.

Always replace a damaged relay with a relay of the same type.

The power trim relays are located on the right-hand side of the outboard engine, under the cowl:

- Power trim relay for lifting (1)
- Power trim relay for lowering (2)

Use only new relays of the following type:

Hella 4RD-931-680-01

- Stop the outboard engine and ensure it cannot restart, by removing the ignition key, for example.
- Remove the cowling (see page 81).
- Release the plug (3) of the affected relay and pull them downwards.
- Pull the relay from the plug.
- Align the new relay onto the plug and push it in.
- Push the plug upward from below until it locks into position.
- Install the cowling (see page 81).

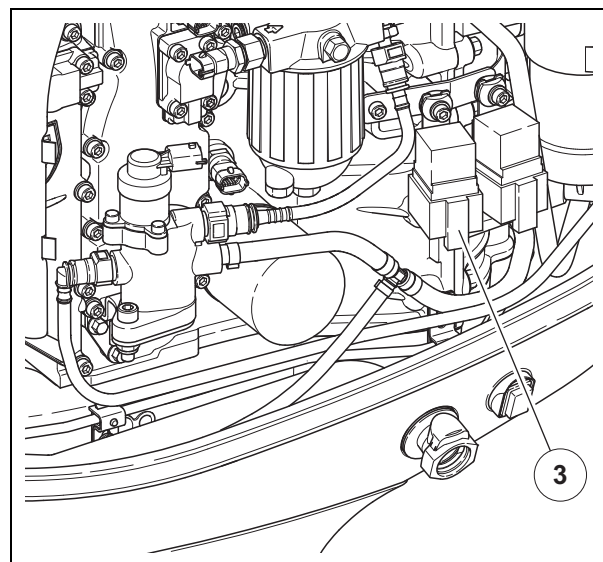
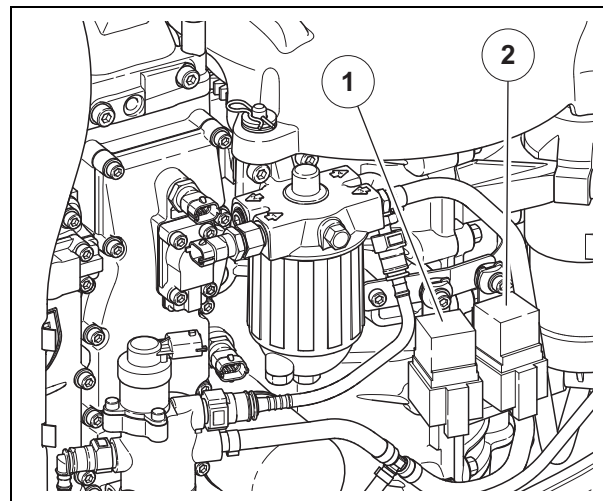

Checking and adjusting the cowl lock

If the cowl no longer locks correctly, its locking pin must be readjusted.

If the cowl is too loose, the corresponding locking pin must be raised. If the cowl no longer locks correctly or at all, the corresponding locking pin must be lowered.

- Stop the outboard engine and ensure it cannot restart, by removing the ignition key, for example.
- Remove the cowling (see page 81).
- Loosen the nut (1) at the front or rear of the cowl.
- Move the locking pin and plate (2).
- Tighten the nut (1).
- Install the cowl (see page 81) and make sure that both locks work properly.

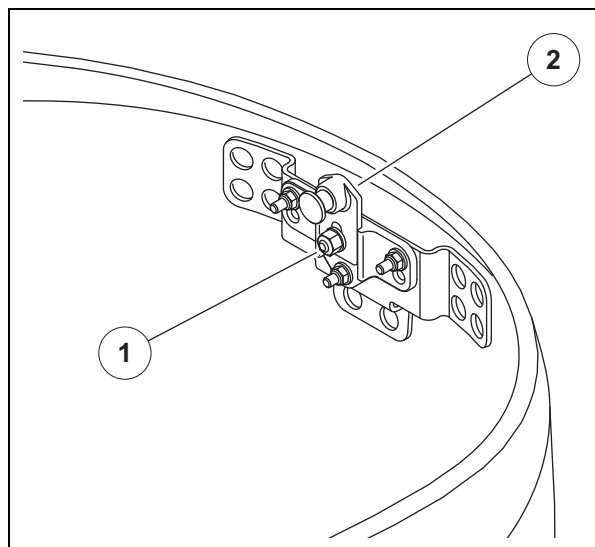

Engine under water

If the outboard engine accidentally goes under the water, it must be overhauled quickly to prevent any corrosion or other consequential damage.

Carry out the following steps:

- Remove the outboard engine as quickly as possible from the water.
- Clean the outboard engine thoroughly with fresh water to remove any salt, dirt or seaweed.
- Flush out the cooling circuit with fresh water (see page 124).
- Check whether there are signs of water in the engine oil. If this is the case, drain the engine oil (see page 137).
- Remove any water from the fuel lines.
- Bring the outboard engine as quickly as possible to an authorized dealer or workshop for reconditioning.

Transport, packaging, storage

Removal from the boat

Preparations for lifting



WARNING

Risk of injury due to heavy weight.

The outboard engine is extremely heavy (at least 175 kg). Only professionals with experience using lifting devices may lift the outboard engine.

- The outboard engine must only be lifted using a crane or hoist with sufficient lifting capacity.
- Always use appropriate lifting gear for anchoring.
- Only the anchor point (1) under the cowling must be used for lifting the device.

Do not attempt to hoist the outboard engine until all of the connections to the boat, tank and remote control (control box) have been disconnected.

Whenever possible, use a loop to connect to the anchor point (1). If using a shackle, ensure that no parts of the engine can be damaged by the shackle coming into contact with them.

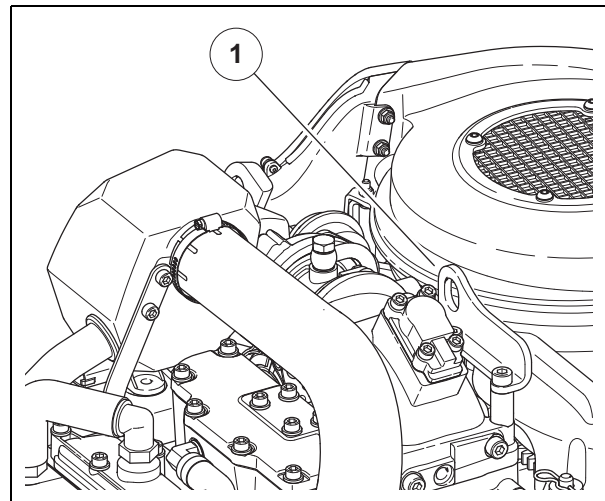

Removal on land



CAUTION

Risk of tipping due to displaced center of gravity.

If the outboard engine is being removed from a boat on a trailer or a frame on land, the center of gravity of the boat will shift as the weight is removed. This means that there is a risk of the trailer, boat or frame tipping forward.

Ensure that the trailer, frame or boat cannot tip over when the outboard engine is removed, for example, by using supports.

Removal in the water



CAUTION

Risk of injury due to movement of the boat.

When an outboard engine is removed from a boat in the water, there is a risk of the watercraft moving unexpectedly. This can result in people on the boat losing their balance and falling, injuring themselves or even going overboard.

Ensure the boat is anchored securely and moves as little as possible.

Twin propulsion

If a linkage for twin propulsion is installed, you will need to remove it first of all.

For more information about the removal of the linkage, refer to the information supplied with it. Pay particular attention to all of the safety precautions for removal.

Disconnecting the steering linkage and control box

If the outboard engine is connected to a control box, you will need to disconnect all of the control cables and leads, as well as the steering linkage, from the engine.

The removal of the steering linkage depends on the model and is not described in this owner's manual.

For more information on removing and handling the steering linkage, refer to the documentation supplied with it.

Disconnecting the battery leads and the fuel lines

The fuel lines and the battery leads must be disconnected from the engine, even when using the tiller handle.

The steps are described in the following sections.

Disconnecting the battery

- Remove the ignition key (2) from the ignition switch to disconnect all the electric loads.
- Cover the ignition switch on the tiller handle with the protective cap (1).
- Remove the lead from the negative pole of the battery first in order to avoid a short circuit between the wrench and metallic parts of the boat.
- Then remove the cable from the positive pole.
- Close or cover all connectors and lead ends with caps.

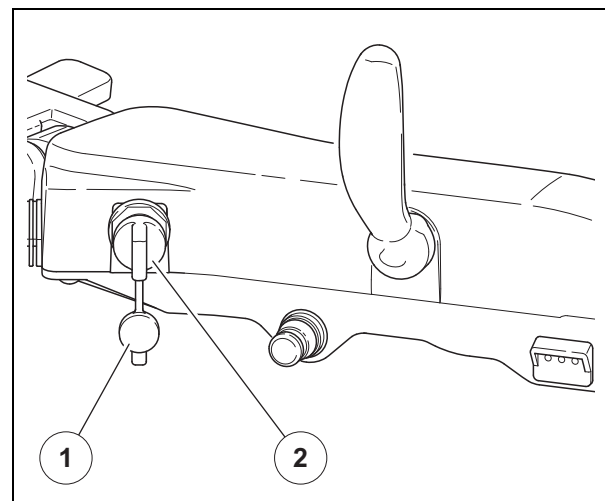

Preparing the duct

When removing the control cables and leads from the outboard engine, you will need to guide them from the engine compartment, under the cowl, through the sealed duct (1).

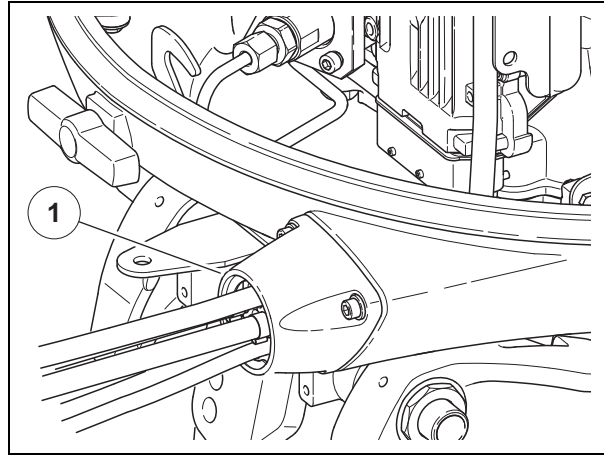

- Remove the 3 screws in the duct cap (2) and store them in a clean place together with the washers.
- Remove the cap.
- Remove the rubber seal (3) from the control cables and leads and store them in a clean place.

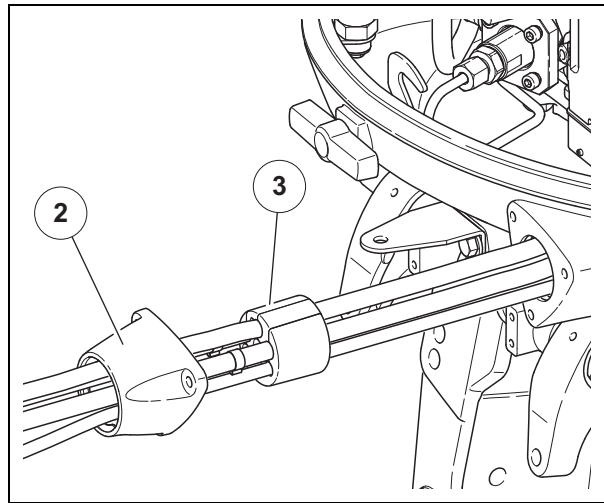

Disconnecting electrical leads

The electrical leads from the control box or from the tiller handle need to be disconnected from the electrical leads on the engine. Each lead is connected with a plug and socket.

Do not use excessive force when disconnecting a plug from its socket. Check first how a plug is locked into the socket, and then release the locking mechanism.

- One by one, pull the plugs from the sockets and close the plugs and sockets with suitable caps.
- Pull all electrical leads through the duct and out of the engine compartment.

Disconnecting the battery leads from the engine

- Completely unscrew the nut (4) from the stud bolt on the starter motor.
- Disconnect the battery lead from the stud bolt and reinstall the nut.
- If there is one, pull the protective cap off the stud bolt on the starter motor switch and a little up along the lead.
- Completely unscrew the nut (5) from the stud bolt.
- Disconnect the battery lead from the stud bolt and reinstall the nut.
- Pull the two battery leads through the duct and out of the engine compartment.
- Close or cover all connectors and lead ends with caps.

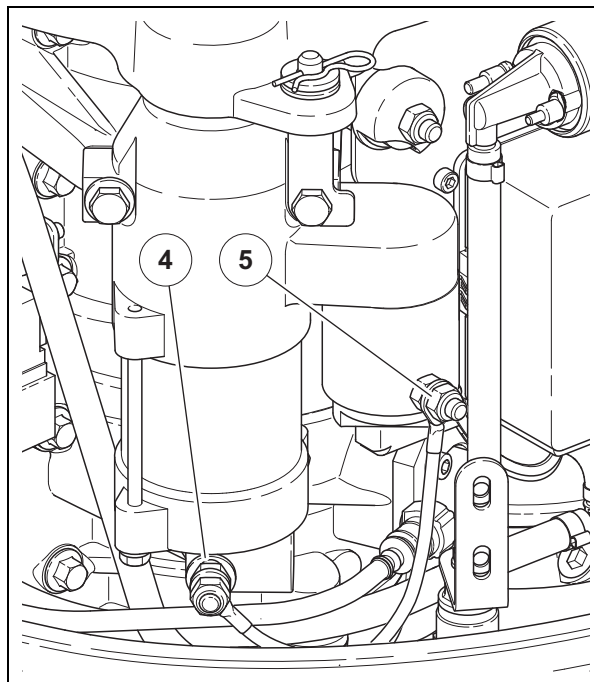

Disconnecting the fuel lines from the engine



CAUTION

Risk of falling due to slippery surfaces.

Even small amounts of leaked fuel can result in people slipping, falling and sustaining serious injuries.

Whenever working on the engine, ensure that the surrounding area and the ground remain free from fuel leaks. Wipe up any leaked fuel immediately.

NOTICE

Risk of environmental damage.

Ensure that any spilled fuel is wiped up and does not get into the water. Dispose of any fuel in accordance with applicable regulations.

- Place an absorbent cloth underneath the fuel line connections in case any fuel escapes.
- Loosen the hose clamp (2) on the fuel line for the supply from the tank and disconnect the hose from the connecting piece at the top of the electric fuel pump.
- Loosen the hose clamp (1) on the fuel line for the return into the tank and disconnect the hose from the straight tee.
- Collect all fuel which has escaped and immediately clean any surfaces with fuel on them.
- Close all open fuel lines with plugs.
- Pull the fuel lines out of the engine compartment.

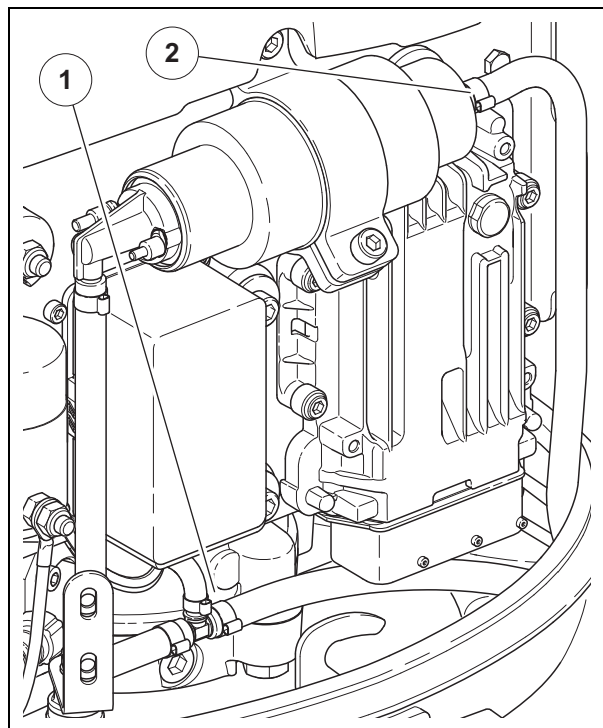

Closing the duct

Once all of the control cables and leads have been disconnected from the engine, you will need to cover the duct using the cap and rubber seal.

- Place the rubber seal into the cap.
- Place the cap with the rubber seal onto the duct.
- Install and tighten the 3 bolts (1) with washers.

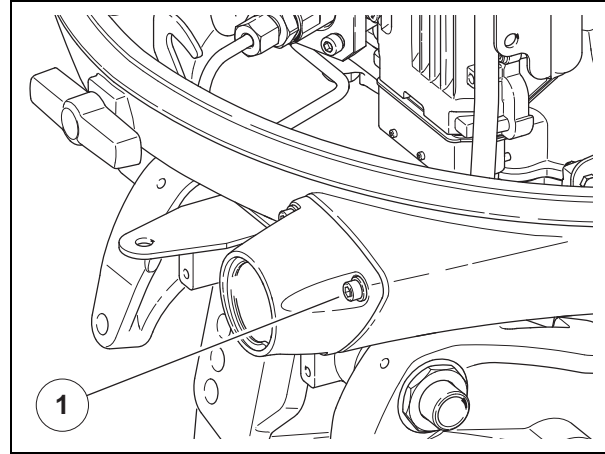

Locking the steering

Before transportation, you must ensure that the outboard engine cannot move by accident in the transom.

If the outboard engine is steered using the tiller handle, you can use the resistance to hold the steering in position.

Alternatively, you can install the transport lock (see page 164).

- Set the lever (2) all the way to starboard, which is the holding position.
- Check whether the tiller handle is held securely in position.
- If you are unsure that the resistance can hold the steering securely in position, you will need to install the transport lock (see page 164).

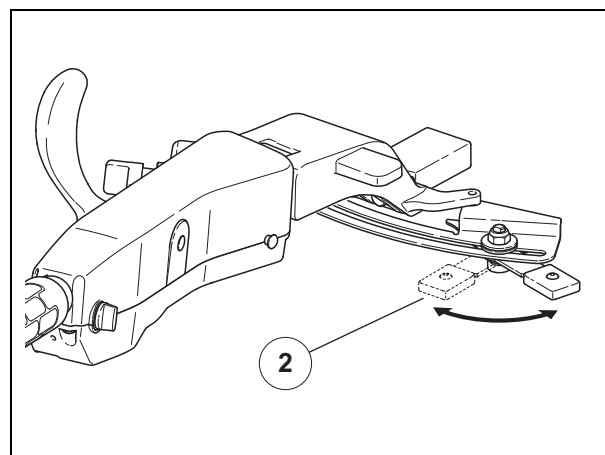

Installing the transport lock



WARNING

Risk of crushing by transom.

There is a risk of crushing with any movement of the transom.

- Keep fingers away from the transom and the area between the transom and casing.
- Install the transport lock as soon as you have removed the steering linkage.

Before transportation, you must ensure that the outboard engine cannot move by accident in the transom.

When operating the outboard engine remotely using a control box and steering linkage, you must install the transport lock as soon as you disconnect the linkage.

If you have lost the transport lock, you can fabricate a new one. Use a steel sheet at least 1.5 mm thick with the dimensions shown in the drawing (see page 176).

- On the front side, underneath the cowl, unscrew both bolts (3) of the connector for the steering linkage.
- Insert a bolt into the larger hole in each plate (2), align the plates and attach them with the screws (3).
- Insert a bolt (1) through the smaller hole in each plate and into the transom and tighten them.
- Ensure that the outboard engine can no longer move.

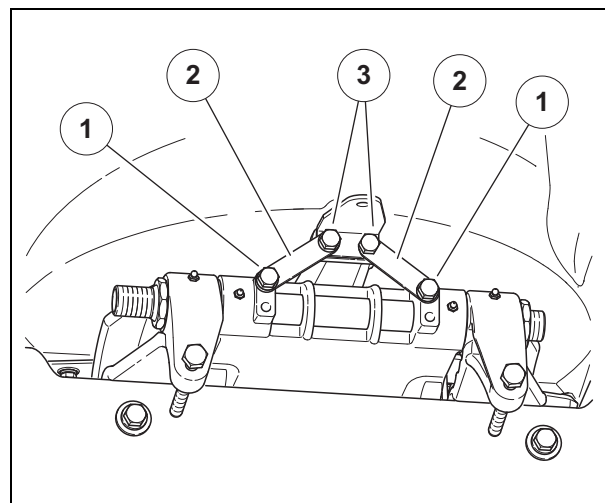

Transport



WARNING

Danger of injury due to weight and asymmetrical load.

The outboard engine is extremely heavy (at least 175 kg). The engine must only be transported upright in a suitable stable steel frame or horizontally on a transport pallet.

- Ensure the outboard engine is attached firmly to the transportation device and is protected against slipping.
- Ensure the center of gravity is marked clearly on the outside of the shipping crate.

Shipping conditions

Bear in mind the following notes when transporting the outboard engine after removing it from the boat:

- Before transport, all of the engine oil must be drained (see page 137) and the cooling circuit must have been completely flushed out with fresh water (see page 124).
- The transport lock must be installed before transporting.
- Whenever possible, the outboard engine should be transported on a transport pallet. Ideally, the original packaging material should be used for transport.
- The outboard engine must never lie on the upper or lower cowling.
- The engine block must be kept above the propeller.
- Alternatively, you can use a steel frame intended for the transportation of outboard engines.
- Protect the outboard engine against slipping by means of lashing straps or bolting, for example.

Trailer transport

Bear the following points in mind when transporting the outboard engine on a boat:

- Take into account the shift in the center of gravity of the boat caused by the heavy weight of the outboard engine at the rear end.
- Let the outboard engine hang in its normal operating position.
- If the distance to the ground is too low, you will need to use a different trailer.
- To avoid injury, install appropriate protective caps on the propeller before transport.

Checking the transport lock



WARNING

Risk of crushing by transom.

There is a risk of crushing with any movement of the transom.

- Only transport the outboard engine with the transport lock installed.
- Keep fingers away from the transom and the area between the transom and casing.

- Make sure that both plates (1) of the transport lock are mounted and secured.
- If there is no transport lock, you must install one before carrying on with any other task (see page 164).
- Alternatively, you can stop the outboard engine from moving by holding the steering resistance (see page 163).

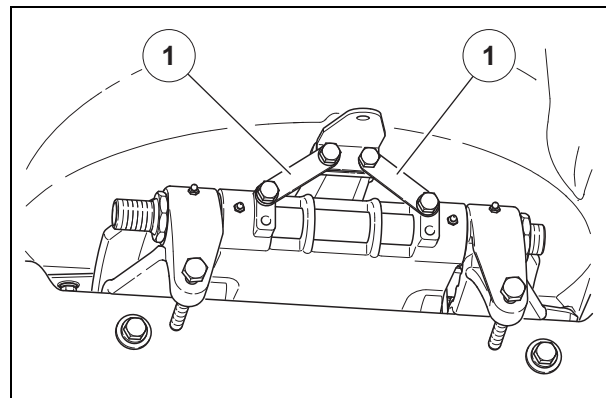

Transport pallet

If you wish to transport the outboard engine horizontally on a transport pallet, use the original transport pallet if possible.

- Check the transport pallet is stable and does not show any signs of damage.
- If there is visible damage to the transport pallet or you are unsure of its stability, do not use it.
- Hammer in any nails which are sticking out.
- Screw in any bolts which are sticking out.

Alternatively, you can use a transport pallet according to the drawing (see page 176). This owner's manual does not provide any more details on that. Please contact an experienced manufacturer of transport solutions.

Fastening to the transport pallet



WARNING

Risk of injury due to heavy weight.

The outboard engine is extremely heavy (at least 175 kg). Only professionals with experience using lifting devices may lift the outboard engine onto the transport pallet.

- The outboard engine must only be lifted using a crane or hoist with sufficient lifting capacity.
- Always use appropriate lifting gear for anchoring.
- Only the anchor point under the cowling must be used for lifting the device.

Do not start lifting the outboard engine until the transport pallet is complete and ready.

Bear in mind the following when attaching the outboard engine to the transport pallet:

- The transport pallet must be accessible from all sides.
- The outboard engine must never lie on the upper or lower cowling. The cowling must not come into contact with the transport pallet.
- Whenever possible, use a loop to connect to the anchor point. If using a shackle, ensure that no parts of the engine can be damaged by the shackle coming into contact with them.

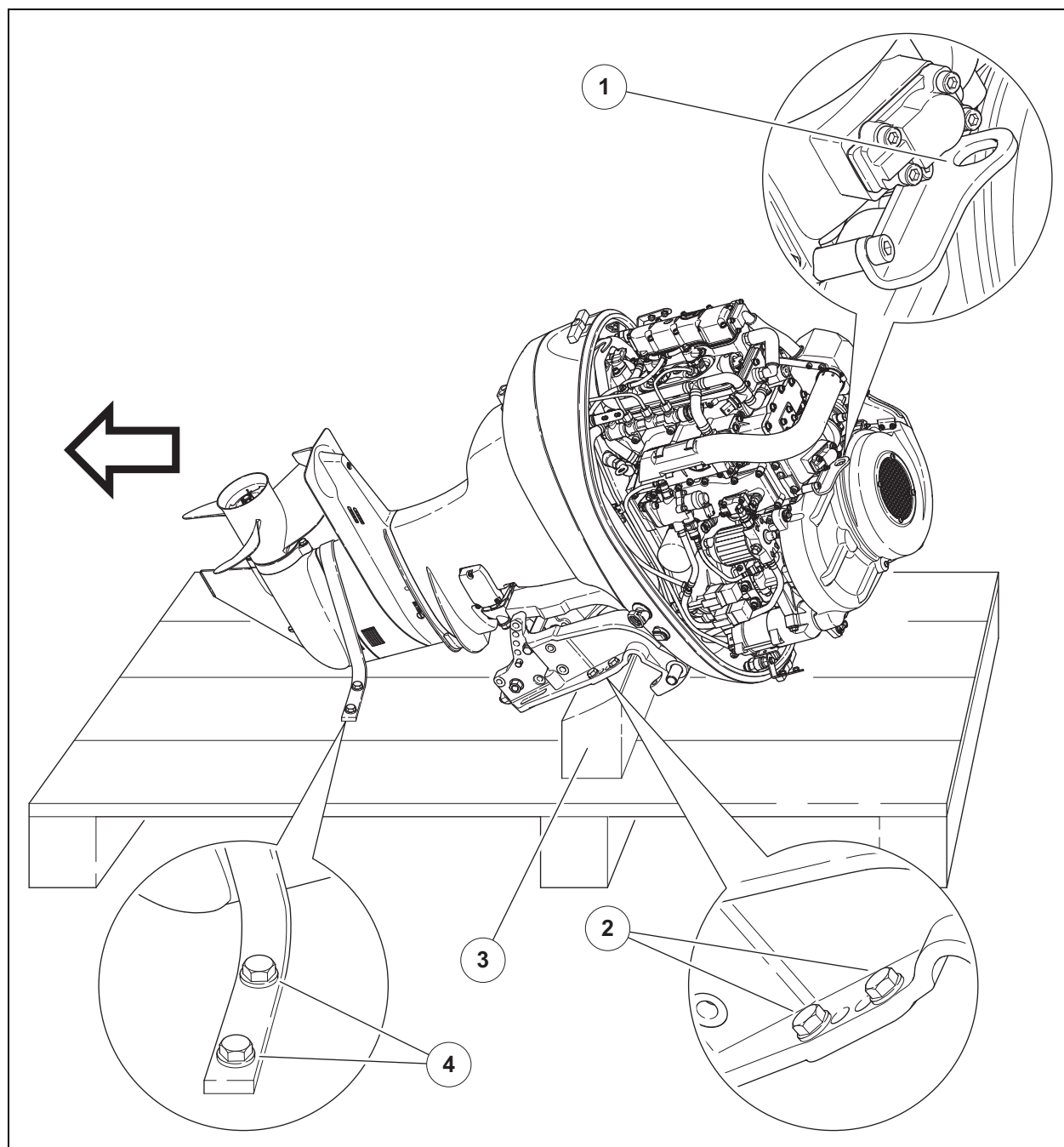

- Remove the cowling (see page 81).
- Attach a loop or any other suitable lifting device to the anchor point (1) and lift the outboard engine.
- Bring the outboard engine over the transport pallet and lower it gently.
- When lowering the outboard engine, guide the fin toward the edge of the pallet (arrow) so that the transom drops exactly onto the crosspiece (3) of the transport pallet.
- Once the transom is seated, install 2 (two) M12 × 200 mm wood screws (2) through the transom into the crosspiece.
- Stretch a strap (for example, perforated tape) over the leg and attach it to the pallet using 2 wood screws (4) on each side.
- Remove the lifting device.
- Install the cowling (see page 81).

Additional packaging

If necessary, you can also add outside walls and a lid to the transport pallet in order to better protect the outboard engine.

Whenever possible, use the original parts provided in the shipping crate. Also use the padding material.

Alternatively, you can use a shipping crate according to the drawing (see page 176). This owner's manual does not provide any more details on that. Please contact an experienced manufacturer of transport solutions.

If you require any further information on suitable packaging for transportation, contact your dealer or Neander Shark directly (see *Further information*, page 12).

Transport pallet transportation



WARNING

Danger of injury due to weight and asymmetrical load.

The outboard engine is extremely heavy (at least 175 kg). The center of gravity is not located at the center of the transport pallet.

- The transport pallet should only be moved using a forklift or pallet truck.
- The transport pallet should not be lifted from the top or moved using a crane.
- Ensure the center of gravity is marked clearly on the outside if you use a shipping crate.

Storage

The outboard engine can be stored in a clean and dry place if you are not going to use it for a prolonged period of time. Observe the following conditions:

- Before storing the outboard engine, disconnect all of the fuel lines and leads.
- Flush out the cooling circuit thoroughly with fresh water (see page 124).
- Clean the outside of the outboard engine thoroughly and dry it carefully.
- Only store the outboard engine upright in a stable and suitable steel frame or horizontally on the transport pallet (see page 167).
- The outboard engine must never lie on the upper or lower cowling.
- Observe the permitted ambient temperature and humidity for storage (see *Technical data* from page 171 onwards).
- Only store the outboard engine in clean, dry areas, where it will not be subjected to extreme changes in temperature or direct sunlight.
- Select a storage location where humidity can run off and periodic inspection is possible.

Appendix

Technical data

Mechanical systems

Engine type	4-stroke turbo diesel in-line engine
No. of cylinders	2 in line
Mass compensation	two counter-rotating crankshafts
Engine displacement	804 cm ³
Bore × stroke	80 × 80 mm
Torque	max. 111 Nm at 2,000 – 3,000 min ⁻¹
Power output	36.77 kW at 3,500 – 4,000 min ⁻¹ (ISO 14396) 50 PS at 3,500 – 4,000 min ⁻¹ (ISO 14396)
Charging	turbocharger, water-cooled with charge air cooling
Lubrication system	integrated dry sump forced-feed lubrication, engine oil capacity 6.5 liters
Injection	Bosch Common Rail direct injection
Cooling	water cooling with circulation pump and dual thermostat
Exhaust	underwater through propeller hub
Control	tiller handle or control box and control mechanism, steering angle -35° – +35°
Mounting	tension- and pressure-controlled by silentblocs
Trimming	power trim, trimming angle (with 12° stern) -4 – +70°
Tilt angle	70°
Transmission	mechanical; rigid coupling
Gear ratio	13/27 (2.07:1)
Propeller	3-blade propeller with built-in damper, clockwise direction of rotation
Lengths of legs	20" and 25"
Weight	175 kg (dry weight, basic version)

Common rail system

Common rail unit	max. operating pressure 1,450 bar, electronic high-pressure sensor; max. measuring range \leq 1,800 bar
Electromechanical fuel pump	suction head 1 m (filled lines), supply rate \geq 80 l/h at system pressure of 4.5 bar
Main fuel filter	filter element 2 μ m resistance to pressure \geq 6 bar
Electromechanical fuel dosing unit	pressure relief valve 4.5 bar \pm 0.3 bar
High-pressure pump	max. operating pressure 1,600 bar
Electromechanical high-pressure injection nozzles	max. operating pressure 1,600 bar, high-pressure outlet via 7-hole nozzle directly into combustion chamber
Ball check valve in the return line	opening pressure \leq 0.6 bar

Electric system

Alternator	Standard 12 V, 300 W
Amperage	1.25 A
Fuses	2 \times 6.3 AT
Starter motor	electric
Starter battery requirements	12 V, min. 75 Ah

Ambient conditions

Water temperature	operation: -5°C – 35°C
Air temperature	operation: -20°C – 50°C storage: -20°C – 60°C
Altitude	max. 1,000 m

Permitted fuels/lubricants

Fuel	diesel fuel in accordance with EN 590*, not permitted: biodiesel, marine diesel, heavy fuel oil, gasoline, at ambient temperatures of < 0 °C: winter diesel/arctic diesel
Engine oil	Shell Rimula R6 M 10W-40, ACEA specification: E7, E4; at ambient temperatures of < 0 °C: Shell Rimula R6 ME 5W-30, ACEA specification: E4
Transmission oil	Q8 T55 80W-90 (API GL-5, MIL-L-2105D)
Hydraulic oil	Dexron-III
Grease	Liqui Moly Boat Grease (KPF2G-20, DIN 51502)

Emissions

Noise emission	< 72 dB (A) maximum SPL L_{pASmax} based on pass-by testing at 25 m distance, according to DIN EN ISO 14509-1:2017-02
Exhaust emissions	within the limits set forth by Directive 2013/53/EU of the European Parliament and of the Council on recreational craft and personal watercraft

Vibration

Overall value at throttle grip on tiller handle	< 2.5 m/s ²
--	------------------------

* The maximum permissible emission levels can only be guaranteed by using diesel fuel in accordance with EN 590. To ensure optimum performance of the outboard engine, only diesel fuel in accordance with EN 590 should be used. The use of other fuel grades can result in increased wear, reduced starting ability and increased soot formation.

Dimensions of outboard engine

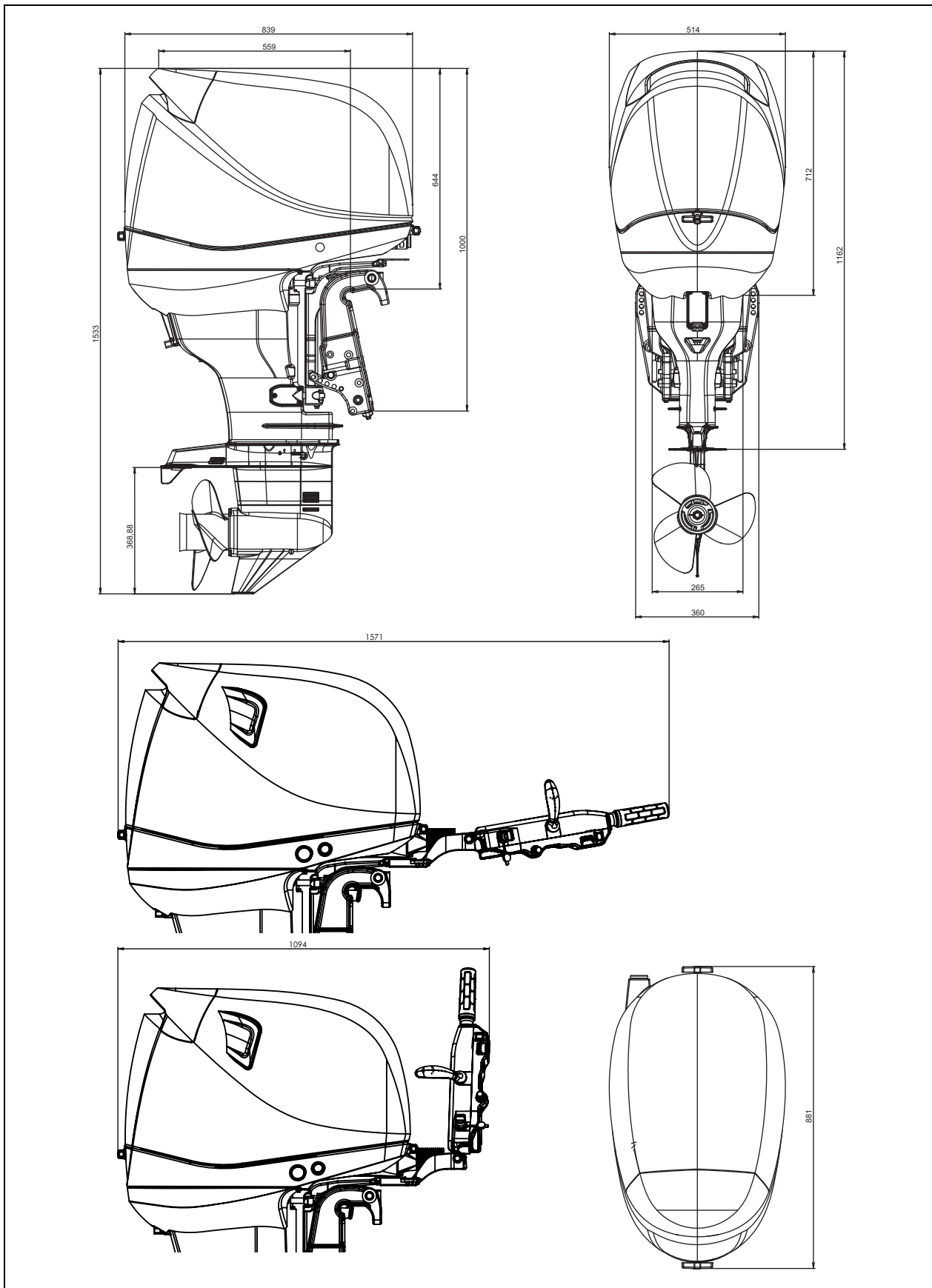

All measurements given in mm.

Dimensions of transom

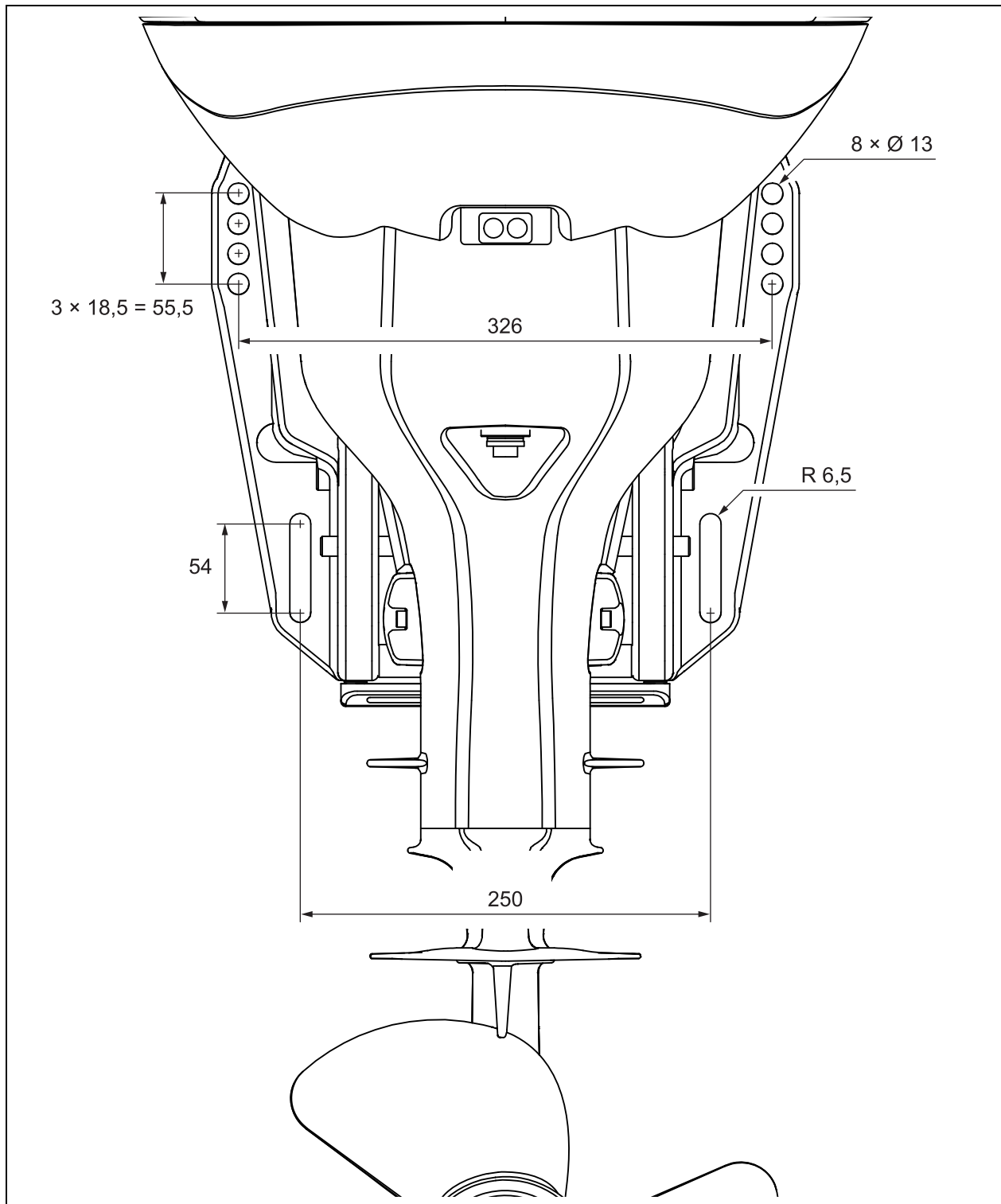

All measurements given in mm.

Dimensions of shipping crate

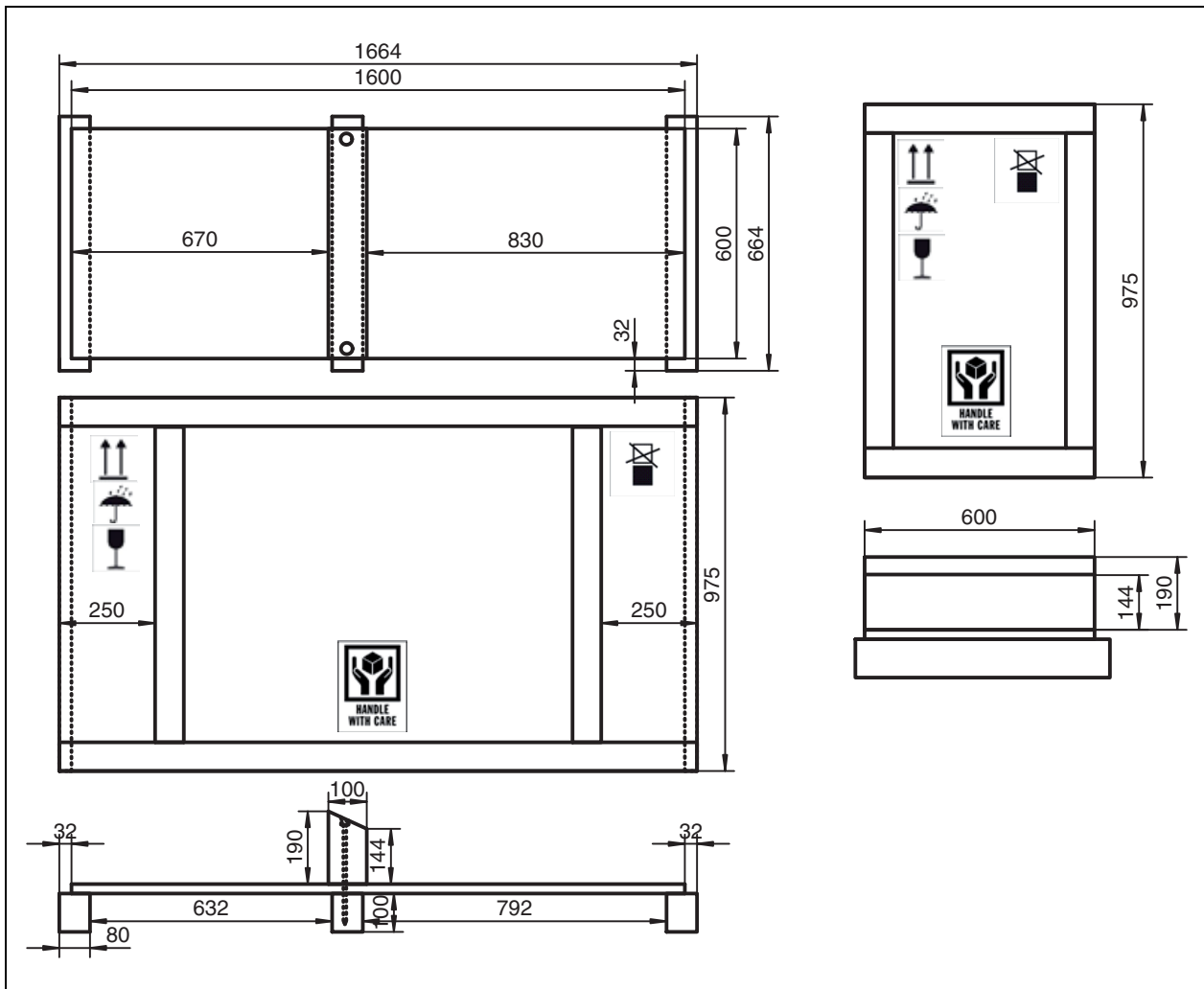

All measurements given in mm.

Dimensions of transport lock

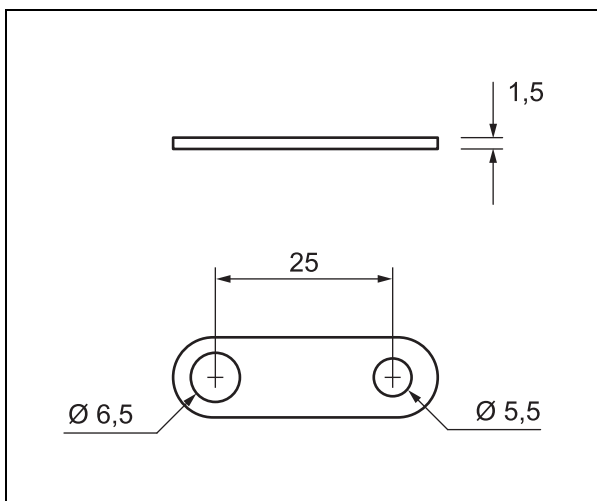

All measurements given in mm.

Fuses and relays

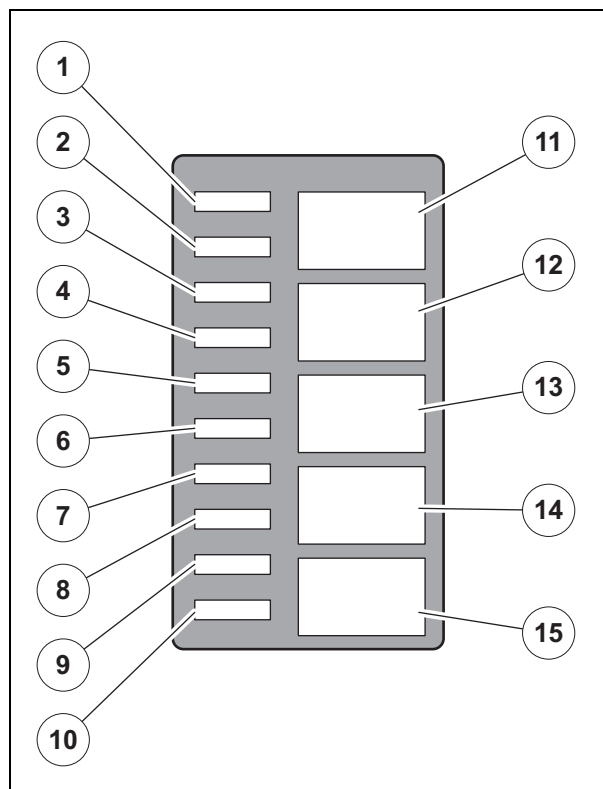

- | | |
|---|-------------------------------|
| 1 not used; spare fuse | 11 Glow plug relay 2 |
| 2 not used; spare fuse | 12 Glow plug relay 1 |
| 3 not used; spare fuse | 13 Fuel pump relay |
| 4 Glow plug relay fuse 2 30 A | 14 Main relay |
| 5 Glow plug relay fuse 1 30 A | 15 Starter motor relay |
| 6 Main relay fuse 20 A | |
| 7 Trim switch fuse 5 A | |
| 8 Fuel pump relay fuse 20 A | |
| 9 Remote control fuse 10 A | |
| 10 Starter motor relay fuse 20 A | |

Accessories

Approved propellers

Material	Blades	Size	Direction
Aluminum/Stainless steel	3	14 × 11	clockwise
Aluminum/Stainless steel	3	13-3/4 × 13	clockwise
Aluminum/Stainless steel	3	13-1/2 × 15	clockwise
Aluminum/Stainless steel	3	13-1/4 × 17	clockwise
Aluminum/Stainless steel	3	13 × 19	clockwise
Aluminum/Stainless steel	3	13 × 21	clockwise
Aluminum/Stainless steel	3	14 × 17	clockwise
Aluminum/Stainless steel	3	14 × 19	clockwise

The size is generally given on the hub of the propeller.

Approved fuel filter inserts

Manufacturer	Type	Size
Parker Racor	R11S	2 microns

Approved fuel filter in the fuel feed line

Manufacturer	Type
Parker Racor	215RM30MTC

Approved fuel lines

Specifications DIN 73379:2014-07

Dimensions 7.5 × 3 mm

Material NBR/PES/CR

Spare parts

ID no.	Name	Quantity
500170	Oil filter Bosch F 026 407 001, incl. seal	1
200305	Oil sump sealing washer	1
200645	Water pressure sensor	1
200123	Fuel filter insert Parker Racor R11S (2 µm), incl. seals	1
203097	Fuel filter insert Parker Racor 215RM30MTC (30 µm), incl. seals	1
403168	Sacrificial anodes; complete set of all anodes	1 set

When ordering, always give the outboard engine designation and serial number, as well as the ID no. of the part. You can find this information on the rating plate (see *Rating plate*, page 20).

Index

A

Accessories 14, 178
Accident prevention regulations 13
Address 12, 20
Adjustment
 Control cables 69
 Shift and throttle lever 69
 Shift lever 69
 Steering resistance 72
 Throttle grip resistance 72
Adjustments
 Trab trim 73
Air 27
Air inlet 31
Air outlet 28, 32
Alternator
 Regulator 28
Alternator regulator 28
Ambient conditions 172
Ambient temperature 79, 172
Anchor point 27, 43, 157
Anode 26, 31
 Replacing 149
Anti-cavitation plate 25, 26, 99
Applications 21
Area of application 21
Assemblies
 Overview 25
Asymmetric thrust 73
Attaching
 to the boat 47
Attention 18

B

Battery 60
 Connecting 66
 Disconnecting 159, 161
 In frost 80
 Installing 60
 Selecting 60
Battery lead 68

Battery leads
 Disconnecting 159, 161
Bolts installation 47
Boost pressure 112
Brackish water 80
Breaking-in instructions 77

C

Casing 25
Caution 18
CE marking 19, 20
Changing gears
 Changing over 91, 93
 Control box 90
 Forward motion 90, 92
 Reversing 91, 93
 Tiller handle 92
Changing over 91, 93
Charging indicator 36, 98
Cleaning 14, 114
 Cleaning fluids 114
 Cooling circuit 114
 Surfaces 114
Cleaning fluids 114
Common rail system 172
Common rail unit 27, 29, 30
Components 25
Connecting leads 65
Connection of leads 65
Connections 62
 Control box 65
 Control cables 63
 Diagnostic tool 65
 Duct 62, 68, 160, 163
 ECU 65, 66
 Fuel tank 67
 Leads 65
 Overview 31
 Speedometer 65
 Tiller handle 65
 Water in fuel alarm 65, 68

- Control 30
 - Steering linkage 32, 52
- Control box 65
 - Adjusting shift and throttle lever 69
 - Connecting 52, 65
 - Connecting instruments 65
 - Disconnecting instruments 160
 - Installing 55
 - Installing steering linkage 52
 - Overview 37
 - Reconfiguring shift and throttle lever 56
- Control cables 28, 32
 - Adjusting 69
 - Connecting 63
- Controls
 - Overview 31
- Cooling circuit
 - Flushing 124
- Cooling water 31
 - In frost 79
- Cooling water inlet 31, 97, 99, 124, 137, 142
- Cooling water pressure 112
- Cooling water temperature 111
- Copyright 11
- Copyright protection 11
- Cowl
 - Adjusting the lock 155
 - Air outlet 32
- Cowling 15, 25
 - Air inlet 31
 - Closing 81
 - Install 81
 - Lock knob 31, 32
 - Opening 81
 - Removing 81
- Crane 43
- Crank case breather 27
- Crushing hazard 17
- Customer service 12
- Cuts 17

- D**
- Damage 119
- Danger 18
- Danger points 16

- Dangers 17
 - Flywheel fan 17
 - Flywheels 17
 - Propeller 17
 - Transom 17
- Declaration of Conformity 19
- Diagnostic tool 65
- Diesel 173
- Dimensions
 - Outboard engine 174
 - Shipping crate 176
 - Transom 175
 - Transport lock 164, 176
 - Transport pallet 176
- Disconnecting
 - Leads 160
- Disconnection 159, 161
- Disengage 33, 37
- Dosing unit 27, 29, 30
- Dual crankshafts 22
- Duct 62, 68, 160, 163

- E**
- ECU 28, 30, 65, 66
 - Power supply 65, 66
- Electric system 172
 - Connecting leads 65
 - Disconnecting leads 160
- Electrical fuses
 - Overview 177
 - Replacing 152
- Electrical installation 14
- Electronic control unit 28, 30
- Emergency stop 15, 84
- Emissions 173
- Engine
 - Switching off 102
 - Under water 156
- Engine block
 - Overview 27
- Engine cut-out 15, 84
- Engine indicator 36

Engine oil 27, 173
 Changing 137
 Dipstick 27
 Draining 137
 Filling hole 27
 Refilling 139
Engine oil filter 27
Engine protection 111
Engine protection functions 111
Engine speed 88
Environmental protection 13, 76
Exhaust 31
 Replacing the cover 133
Exhaust gas 31
Explosion hazard 19
Explosion prevention 19

F

Fastening
 Transport pallet 166
Fault code 36
Faults 14
Feedback 12
Feedback on the
 owner's manual 12
Filling hole 27
Filter 61
Filter element
 Replacing 128, 130
Fin 25
Fixing bolts 47
 Sizes 47
Flushing 80, 124
Flushing adapter 124
Flushing connector 31, 124
Flywheel fan 15, 16, 27
 Air outlet 28, 32
 Dangers 17
Flywheel fan guard 15, 16, 27
Flywheels 15, 16, 27
 Dangers 17
Forward motion 90, 92
Forward travel 33, 37

Frost 79
 Battery 80
 Cooling water 79
 Fuel 79
Fuel 173
 In frost 79
 Water alarm 65, 68
Fuel circuit 30
Fuel control unit 27, 29, 30
Fuel filter 27, 29, 30, 61
 Insert 179
 Installing 61
 Replacing the element 128, 130
Fuel line 29, 68
 Connecting 67
 Disconnecting 162
 Specifications 179
Fuel pre-filter 61
Fuel pump 28, 29, 30, 67, 162
Fuel system 29
Fuel tank 61
 Cleaning 130
 Connecting 67
 Disconnecting 162
 Installing 61
Fuels/lubricants 13, 14, 173
Further information 12
Fuses 28
 Overview 177
 Replacing 152

G

Glow plug relay 28
Grease 173

H

Help 12
High-pressure injection nozzles 29, 30
High-pressure line 29
High-pressure pump 28, 29, 30
Hoist 43
Hoisting 43, 157
Hotline 12

Hydraulic oil 173
Refilling 142

I

Identification 20
Idle relief
 Replacing the cover 133
Ignition key 33, 34, 37, 38
Ignition switch 33, 34, 37, 38
Indicators 33, 36
 Fault code 36
 Overview 31
Information 12
Injection nozzles 29, 30
Inspection 115
 Before each operation 82
 Propeller 119
Inspection intervals 115
Installation 41, 45
 Fixing bolts 47
 Requirements 45
 Trailer 46, 158
Installation requirements 45
Instruments
 Connecting 65
 Disconnecting 160
Intake manifold 27
Intercooler 28
Intervals
 Inspection 115
 Maintenance 77, 122

K

Kill switch lanyard 15, 33, 37, 84
 Test 84

L

Leads, disconnecting 160
Leg 25
Lifting 43
Lifting gear 27
Limits of use 19
Lock knob 31, 32

Lubrication 14, 135
 Propeller shaft 136
 Shift lever 136
 Transom 135

M

Mailing address 12
Main fuel filter 30
Main lead 68
Maintenance intervals 77, 122
Maintenance tasks
 Safety 122, 144
Material damage 13
Measurements
 Outboard engine 174
 Shipping crate 176
 Transom 175
 Transport lock 164, 176
 Transport pallet 176
Mechanical systems 171
Model name 20
Modifications 14
Mount 16, 17, 25, 26
 Dangers 17
 Dimensions 175

N

Neutral 15, 35, 39
Neutral lock 37
Neutral position 15, 35, 39, 89, 92, 93
Noises 106

O

Occupational safety regulations 13
Oil 173
 Changing 137, 140
 Draining 137, 140
 Refilling 139, 141
Oil change 137, 140
Oil dipstick 27
Oil drain plug 32, 138, 140
Oil fill level
 Checking 118

- Oil filter
 - Replacing 131
- Oil pressure 112
- Oil separator 28
- Oil temperature 111
- Operating conditions 14
- Operation 75
 - Ending 101
 - Low temperatures 79
 - Safety 75
 - Salt water 80
- Overview
 - Assemblies 25
 - Connectors 31
 - Control box 37
 - Controls 31
 - Engine block 27
 - Indicators 31
 - Tiller handle 33
- owner's manual
 - Copyright protection 11
 - Purpose 11
 - Scope 11
 - Storage location 11
 - Target readership 11
 - Transferring 12
- Pre-feed pump 28, 29, 30, 67, 162
- Preparations for installation 45
- Preparations for start-up 82
- Preparing for operation 82
- Propeller 16, 17, 25, 26, 178
 - Dangers 17
 - Exhaust 31
 - Inspection 119
 - Installing 147
 - Removing 146
 - Repairing 144
 - Replacing 145
 - Selecting 145
 - Size 178
- Propeller shaft
 - Lubricating 136
- Propeller walk 73
- Protection devices
 - Overview 15
- Protection functions 111
- Protective equipment 13, 14

Q

- Quick stop 33, 37

P

- Packaging 169
 - Lifting the outboard engine 43
 - Removing 42
 - Shipping crate 41
 - Transport pallet 43, 167
 - Transporting 42, 169
- Packaging materials 41
- Padding 41
- Personal protective equipment 13
- Pinging 106
- Power output 45
- Power trim 25, 26, 96
 - Hydraulic oil 142
 - Relay 27
 - Trim switch 31, 33, 37
- Power trim relay 27, 154
 - Replacing 154
- PPE 13

R

- Rating plate 20
- Reconfiguring the shift and throttle lever 56
- Refueling 82
- Relay
 - Replacing 153, 154
- Relays
 - Overview 177
- Removal 157
- Removing 157
- Repair 14, 144
- Repairs 14, 144
- Resistance 33, 35
- Reverse travel 31, 33, 37
- Reversing 91, 93
- Risk of injury 17
- Rust 108

S

- Sacrificial anode 26, 31
 - Checking 120
 - Replacing 149
 - Shaft 151
 - Trab trim 150
 - Transom 150
 - Vibration damper 151
- Safety 13
 - Maintenance tasks 122, 144
 - Material damage 13
 - Operation 75
 - Organizational measures 13
 - People 13
 - Safety features 15
- Safety features 15
 - Inspecting 116
 - Kill switch lanyard 15
 - Overview 15
 - Stop button 15
- Safety precautions 14, 18
- Salt deposits 108
- Salt water 80
- Scope 11
- Scope of delivery 20
- Serial number 20
- Service 12, 122
- Service tasks 14
- Settings 69
- Shaft 25
- Shift and throttle lever
 - Adjusting 69
- Shift control cable 68
- Shift lever 15, 28, 33, 35, 37, 39
 - Adjusting 69
 - Lubrication 136
 - Resistance 37
- Shipping
 - Conditions 165
- Shipping crate 41
 - Dimensions 176
- Signs 121
- Sizes
 - Fixing bolts 47
- Smoke 107
- Spaceball 23
- Spare parts 180
- Specifications 171
 - Common rail system 172
 - Electric system 172
 - Emissions 173
 - Fuel filter 179
 - Fuel line 179
 - Fuels/lubricants 173
 - Mechanical systems 171
 - Propeller 178
- Speedometer
 - Connecting 65
- Starter interlock 15
 - Testing 117
- Starter motor 27
- Starter relay 28
- Starting 85
 - Cold start 78
 - First start 87
 - Normal start 85
- Start-up 14, 85, 103
 - Cold start 78
 - First start 87
 - Normal start 85
 - Safety 75
 - Starter interlock 15
- Steam 107
- Steering 94
 - Locking 163
 - Steering resistance 95
- Steering linkage 15, 51
 - Disconnecting 159
 - Installing 52
 - Mount 32
- Steering resistance
 - Adjusting 72
 - Holding 95
 - Installing 59
- Stickers 121
- Stop 15, 84
- Stop button 15, 33, 34, 37, 38, 84
 - Testing 117
- Stopping 100
 - Safety 76
- Storage 170
- Storage location 11
- Supplementary battery lead 68

- Surface rust 108
Switching off 102
- T**
- Tank
 Connecting 67
 Disconnecting 162
 Installing 61
- Target readership 11
- Technical data 171
 Common rail system 172
 Dimensions 174, 175, 176
 Electric system 172
 Emissions 173
 Fuel filter 179
 Fuel line 179
 Fuels/lubricants 173
 Mechanical systems 171
 Propeller 178
- Temperature 79, 172
- Throttle control cable 68
- Throttle grip 33, 35
 Adjusting the resistance 72
 Resistance 33, 35
- Throttle lever 37, 39
 Resistance 37
- Throttle lever, warm-up 39
- Throttle position sensor 28, 30
- Tiller handle 65
 Connecting 65
 Indicators 33, 36
 Installing 58
 Overview 33
 Shift lever adjustment 69
 Warning lights 99
- Tilting 101
- Trab trim 26, 31, 145
 Adjusting 73
 Checking 120
 Replacing 149
- Trailer
 Installation 46, 158
 Transport 165
- Transfer 12
- Transmission oil 173
 Changing 140
 Drain hole 32, 140
 Draining 140
 Refilling 141
 Ventilation hole 32, 140, 141
- Transom 16, 17, 25, 26
 Dangers 17
 Dimensions 175
 Lubricating 135
- Transport 165
 Shipping crate 41
 Trailer 165
 Transport lock 166
- Transport lock 15, 166
 Dimensions 164, 176
 Fabricating 164
 Installing 164
 Removing 51
- Transport pallet 43, 166, 167
 Dimensions 176
 Fastening the outboard engine 167
 Transportation 169
- Transportation
 Transport pallet 169
- Transporting
 Shipping crate 42
- Travel 88
 Breaking-in phase 77
 Changing gears 90, 92
 Economical operation 97
 Ending 101
 Power trim 96
 Refueling 82
 Safety 76
 Shallow water 97
 Steering 94
 Steering resistance 95
 Stopping 100
 Traveling slowly 98
 Trimming 96
- Trim pin 32
- Trim switch 31, 33, 35, 37, 40
- Trimming 96
- Turbocharger 28

Twin propulsion
 Installation 49
 Removal 158
 Trab trim 73

U

Unpacking 41

V

Ventilation hole 32, 140, 141
Vibration 173
Visual inspection 116

W

Warm-up 37, 39, 78
Warning 18
Warning lights 99
Warning signs 121
Water separator 27, 29, 61
 Emptying 126, 130
Website 20
Weight 45
Wiring, disconnecting 160

Z

Zinc anode 26, 31
 Checking 120
 Replacing 149